

**INSTALLATION AND OPERATION MANUAL
FOR SEA TEL MODEL
9497B-20 QUAD KU-BAND TVRO ANTENNA**

Sea Tel, Inc.
4030 Nelson Avenue
Concord, CA 94520
Tel: (925) 798-7979
Fax: (925) 798-7986
Email: seatel@cobham.com
Web: www.cobham.com/seatel



Sea Tel Europe
Unit 1, Orion Industrial Centre
Wide Lane, Swaythling
Southampton, UK SO 18 2HJ
Tel: 44 (0)23 80 671155
Fax: 44 (0)23 80 671166
Email: seatel@cobham.com
Web: www.cobham.com/seatel

Sea Tel Inc doing business as Cobham SATCOM

November 3, 2008

Document. No. 128371 Revision A1



These commodities, technology or software were exported from the United States in accordance with the Export Administration Regulations. Diversion contrary to U.S. law is prohibited.



Sea Tel Marine Stabilized Antenna systems are manufactured in the United States of America.



Sea Tel is an ISO 9001:2000 registered company. Certificate Number 19.2867 was issued August 12, 2005. Sea Tel was originally registered on November 09, 1998.



The Series 00 Family of Marine Stabilized Antenna Pedestals with DAC-97 or DAC-03 Antenna Control Unit complied with the requirements of European Norms and European Standards EN 60945 (1997) and prETS 300 339 (1998-03) on April 6, 2004. Sea Tel document number 122982 European Union Declaration of Conformity for Marine Navigational Equipment is available on request.

Copyright Notice

All Rights Reserved. The information contained in this document is proprietary to Sea Tel, Inc.. This document may not be reproduced or distributed in any form without the consent of Sea Tel, Inc. The information in this document is subject to change without notice.

Copyright © 2008 Sea Tel, Inc.



Sea Tel[®]
Marine Stabilized Antenna Systems
European Union Declaration of Conformity
Marine Navigational Equipment

The EU Directives Covered by this Declaration:

European Norms and European Standards EN 60945 (1997) and prETS 300 339 (1998-03).

The Product Covered by this Declaration:

Series 97 Family of Marine Stabilized Antenna Pedestals with DAC-97 Antenna Control Unit

The Basis on which Conformity is being Declared:

The product identified above complies with the requirements of the above EU Directives by meeting the following standards on July 20, 1999:

*** EN 60945 (1997) "Marine Navigational Equipment - General Requirements – Methods of Testing and Required Test Results":**

- Conducted Emissions (Clause 9.1 & 9.2)
- Radiated Emissions (Clause 9.1 & 9.3)
- Conducted Low Frequency Interference (Clause 10.1 & 10.2)
- Conducted Radiofrequency Interference (Clause 10.1 & 10.3)
- Radiated Radiofrequencies (Clause 10.1 & 10.4)
- Fast Transients on Signal/Control Lines (Clause 10.1 & 10.5)
- Surges on AC Power Lines (Clause 10.1 & 10.6)
- Power Supply Short-Term Variation (Clause 10.1 & 10.7)
- Power Supply Failure (Clause 10.1 & 10.8)
- Electrostatic Discharge (Clause 10.1 & 10.9)
- Compass Safe Distance (Clause 11.2, Measurement Only)
- Electromagnetic RF Radiation (Clause 12.2)

*** prETS 300 339 (1998-03) Electromagnetic compatibility and Radio spectrum Matters (ERM); General ElectroMagnetic Compatibility (EMC) for Radio Communications Equipment.**

- Antenna Port Spurious Emissions (Clause 8.4)
- RF Radiated Field Immunity (Clause 9.3)
- Voltage Dips & Short Interruptions (Clause 9.4)
- RF Common Mode Immunity (Clause 9.4, 9.5 & 9.6)

The technical documentation required to demonstrate that this product meets the requirements of the EMC Directive has been compiled by the signatory below and is available for inspection by the relevant enforcement authorities. The CE mark was first applied in 1999.

Authority: Mr. J. Patrick Matthews
President

Signature: 
Date: 7/25/02

Attention

The attention of the specifier, purchaser, installer or user is drawn to special measures and limitations to use which must be observed when the product is taken into service to maintain compliance with the above directives. Details of these special measures and limitations are in the product manual.

RF Transmit and Receive equipment components (Radio Packages, Drivers, HPAs and LNCs) or TVRO LNBS which are mounted on the Marine Stabilized Antenna Pedestal must be CE marked separately by the manufacturer of those components.



Sea Tel, Inc.
4030 Nelson Ave.
Concord, CA. 94520
Phone: (925) 798-7979
Fax: (925) 798-7986



Doc 119360-A

Revision History

REV	ECO#	Date	Description	By
A	N/A	September 2, 2008	Initial Production Release	MDN
A1	N/A	October 30, 2008	Updated logo and font	MDN

Table of Contents

1. INTRODUCTION	1-1
1.1. GENERAL DESCRIPTION OF SYSTEM	1-1
1.2. PURPOSE	1-1
1.3. SYSTEM COMPONENTS	1-1
1.4. GENERAL SCOPE OF THIS MANUAL	1-2
1.5. QUICK OVERVIEW OF CONTENTS	1-2
2. OPERATION	2-1
2.1. SYSTEM POWER-UP	2-1
2.1. ANTENNA INITIALIZATION	2-1
2.2. ANTENNA STABILIZATION	2-1
2.3. STABILIZED PEDESTAL ASSEMBLY OPERATION	2-1
2.4. TRACKING OPERATION	2-1
2.5. ANTENNA POLARIZATION OPERATION	2-2
2.6. LOW NOISE BLOCK CONVERTER OPERATION	2-2
2.7. RADOME ASSEMBLY OPERATION	2-2
3. BASIC SYSTEM INFORMATION	3-1
3.1. SATELLITE BASICS	3-1
3.1.1. <i>Ku-Band Receive Frequency (10.95-12.75GHz)</i>	3-1
3.1.2. <i>Blockage</i>	3-1
3.1.3. <i>Rain Fade</i>	3-1
3.1.4. <i>Signal level</i>	3-1
3.1.5. <i>Satellite Footprints</i>	3-2
3.1.6. <i>Linear Satellite polarization</i>	3-2
3.2. ANTENNA BASICS	3-2
3.2.1. <i>Unlimited Azimuth</i>	3-2
3.2.2. <i>Elevation</i>	3-2
3.2.3. <i>Feed Assembly</i>	3-3
3.2.4. <i>Antenna polarization</i>	3-3
3.2.5. <i>Stabilization</i>	3-3
3.2.6. <i>Search Pattern</i>	3-3
3.2.7. <i>Tracking Receiver - Satellite Identification Receiver</i>	3-3
3.2.8. <i>Tracking</i>	3-3
3.3. COMPONENTS OF THE SYSTEM CONFIGURATION	3-4
3.3.1. <i>Antenna ADE Assembly</i>	3-5
3.3.2. <i>Antenna Control Unit</i>	3-5
3.3.3. <i>Above Decks AC Power Supply</i>	3-6
3.3.4. <i>Satellite Receivers</i>	3-6
3.3.5. <i>Television/Monitor</i>	3-6
3.3.6. <i>Matrix Switch</i>	3-6
4. INSTALLATION	4-1
4.1. GENERAL CAUTIONS & WARNINGS	4-1
4.2. SITE SURVEY	4-2
4.3. PREPARING FOR THE INSTALLATION	4-2
4.3.1. <i>Unpack Shipping Crates</i>	4-2
4.3.2. <i>Inspect / Inventory</i>	4-2
4.3.3. <i>Prepare ADE Mounting Location</i>	4-2
4.3.4. <i>Preparing BDE Location</i>	4-2

Table of Contents

4.3.5.	<i>Installing The System Cables</i>	4-2
4.4.	ASSEMBLING THE ADE	4-2
4.4.1.	<i>144" Radome, Baseframe and Antenna Pedestal System Assembly</i>	4-2
4.4.2.	<i>Preparing the ADE for Lift</i>	4-4
4.5.	INSTALLING THE ADE	4-4
4.5.1.	<i>Hoist</i>	4-4
4.5.2.	<i>Install Antenna/Radome/Baseframe</i>	4-4
4.6.	INSTALL BDE EQUIPMENT	4-4
4.6.1.	<i>ACU & TMS</i>	4-4
4.6.2.	<i>Other BDE Equipment</i>	4-4
4.7.	CABLE TERMINATIONS	4-4
4.7.1.	<i>At The Radome</i>	4-4
4.7.2.	<i>ACU & TMS</i>	4-5
4.7.3.	<i>Other BDE Equipment</i>	4-5
4.8.	FINAL ASSEMBLY	4-5
4.8.1.	<i>Remove Stow Braces/Restraints</i>	4-5
4.8.2.	<i>Verify all assembly and Wiring connections</i>	4-5
4.8.3.	<i>Balance Antenna Pedestal</i>	4-5
4.9.	POWER-UP THE ADE	4-5
4.9.1.	<i>Initialization</i>	4-5
4.9.2.	<i>Home Flag Position</i>	4-5
4.9.3.	<i>BDE</i>	4-5
4.10.	SETUP	4-5
5.	SETUP	5-1
5.1.	OPERATOR SETTINGS	5-1
5.2.	OPTIMIZING TARGETING	5-1
5.3.	OPTIMIZING AUTO-POLARIZATION TVRO	5-1
5.4.	CALIBRATING RELATIVE ANTENNA POSITION (HOME FLAG OFFSET)	5-1
5.4.1.	<i>To Calculate HFO:</i>	5-2
5.4.2.	<i>To Enter the HFO value:</i>	5-3
5.5.	RADIATION HAZARD AND BLOCKAGE MAPPING (AZ LIMIT PARAMETERS)	5-4
5.6.	TX POLARITY SETUP	5-4
5.7.	TRACK DISP	5-4
5.8.	ACU FACTORY DEFAULT PARAMETER SETTINGS – SERIES 97A & SERIES 00 ANTENNAS	5-5
6.	FUNCTIONAL TESTING	6-1
6.1.	ACU / ANTENNA SYSTEM CHECK	6-1
6.2.	LATITUDE/LONGITUDE AUTO-UPDATE CHECK	6-1
6.3.	SHIP HEADING – GYRO COMPASS FOLLOWING CHECK	6-1
6.4.	AZIMUTH & ELEVATION DRIVE	6-1
6.5.	FOUR QUADRANT TRACKING TEST	6-1
6.6.	BLOCKAGE SIMULATION TEST	6-2
7.	MAINTENANCE AND TROUBLESHOOTING	7-1
7.1.	WARRANTY INFORMATION	7-1
7.2.	RECOMMENDED PREVENTIVE MAINTENANCE	7-1
7.2.1.	<i>Check ACU Parameters</i>	7-1
7.2.2.	<i>Latitude/Longitude Auto-Update check</i>	7-1
7.2.3.	<i>Heading Following</i>	7-1

Table of Contents

7.2.4.	Azimuth & Elevation Drive	7-2
7.2.5.	Test Tracking.....	7-2
7.2.6.	Visual Inspection - Radome & Pedestal	7-2
7.2.7.	Mechanical Checks	7-2
7.2.8.	Check Balance	7-2
7.2.9.	Observe Antenna Initialization.....	7-2
7.3.	TROUBLESHOOTING.....	7-2
7.3.1.	Theory Of Stabilization Operation.....	7-2
7.3.2.	Series 97B-20 Quad Ku-Band TVRO RF Flow.....	7-3
7.3.3.	Antenna Initialization (Series 97B & Series 00)	7-4
7.3.4.	Troubleshooting using DacRemP.....	7-4
7.3.5.	Antenna Loop Error Monitoring	7-5
7.3.6.	Reference Sensor Monitoring.....	7-6
7.3.7.	Open Loop Rate Sensor Monitoring	7-8
7.3.8.	Open Loop Motor Test.....	7-9
7.3.9.	To Disable/Enable DishScan	7-9
7.3.10.	Satellite Reference Mode	7-9
7.3.11.	To Read/Decode an ACU Error Code 0008 (Pedestal Function Error):	7-10
7.3.12.	Remote GPS LAT/LON Position:.....	7-12
7.4.	MAINTENANCE.....	7-14
7.4.1.	Balancing the Antenna.....	7-14
7.4.2.	To Adjust Tilt:	7-14
7.4.3.	To Reset/Reinitialize the Antenna:.....	7-16
7.5.	PEDESTAL CONTROL UNIT CONFIGURATION (xx97B & xx00).....	7-17
7.5.1.	MODEL CONFIGURATION NUMBERS	7-17
7.6.	ANTENNA STOWING PROCEDURE.....	7-18
8.	9497B-20 TECHNICAL SPECIFICATIONS.....	8-1
8.1.	9497 ANTENNA REFLECTOR.....	8-1
8.2.	FEED ASSEMBLIES.....	8-1
8.2.1.	TVRO Quad Ku-Band Feed Assembly.....	8-1
8.3.	PEDESTAL CONTROL UNIT (PCU).....	8-1
8.4.	STABILIZED ANTENNA PEDESTAL ASSEMBLY	8-2
8.5.	UNLIMITED AZIMUTH MODEMS (3 CHANNEL).....	8-2
8.6.	144" RADOME ASSEMBLY	8-3
8.7.	ENVIRONMENTAL CONDITIONS (ADE)	8-3
8.8.	CABLES.....	8-4
8.8.1.	Antenna Control Cable (Provided from ACU-MUX)	8-4
8.8.2.	Antenna L-Band TVRO IF Coax Cables (Customer Furnished).....	8-4
8.8.3.	AC Power Cable (Pedestal & Rf Equipment).....	8-4
8.8.4.	Gyro Compass Interface Cable (Customer Furnished).....	8-4
8.8.5.	Fiber Optic Transmitter (CFE Optional).....	8-4
9.	MODEL 9497B-20 DRAWINGS.....	9-1
9.1.	MODEL SPECIFIC DRAWINGS.....	9-1
9.2.	SERIES 97A & 00 GENERAL DRAWINGS	9-1

Table of Contents

This Page Intentionally Left Blank

1. Introduction

1.1. General Description of system

Your Series 00 system is a fully stabilized antenna that has been designed and manufactured so as to be inherently reliable, easy to maintain, and simple to operate. Except for start-ups, or when changing to operate with different transponders or satellites, the equipment essentially permits unattended operation.

1.2. Purpose

This shipboard Television Receive Only (TVRO) system provides you with satellite TV programming while inport or underway. Your Series 00 Antenna system will receive signals of adequately high E.I.R.P. levels (see the Specifications section of this manual), in linear or circular polarization mode from any of the geosynchronous TV satellites at C-Band or Ku-band frequencies (dependant upon currently installed feed assembly). This input will be distributed to all of your satellite TV receivers which will provide the Audio/Video to your Televisions. Many satellites also provide CD quality audio programming which may also be routed to your stereo equipment.

1.3. System Components

Your Series 00 TVRO Antenna system consists of two major groups of equipment; an above-decks group and a below-decks group. Each group is comprised of, but is not limited to, the items listed below. All equipment comprising the Above Decks is incorporated inside the radome assembly and is integrated into a single operational entity. For inputs, this system requires only an unobstructed line-of-sight view to the satellite, Gyro Compass input and AC electrical power. Video and Audio outputs from your satellite receivers are available for distribution and monitoring.

For more information about these components, refer to the Basic System Information section of this manual.

A. Above-Decks Equipment (ADE) Group

1. Stabilized antenna pedestal
2. Antenna Reflector
3. Feed Assembly with LNB(s)
4. Radome Assembly

B. Below-Decks Equipment Group

5. Antenna Control Unit
6. 2 or 4 input Matrix Switch with desired number of outputs (one output to the ACU plus enough outputs for the installed satellite receivers).
7. Satellite Video Receiver(s) & Television(s)
8. Control, RF and Video cables

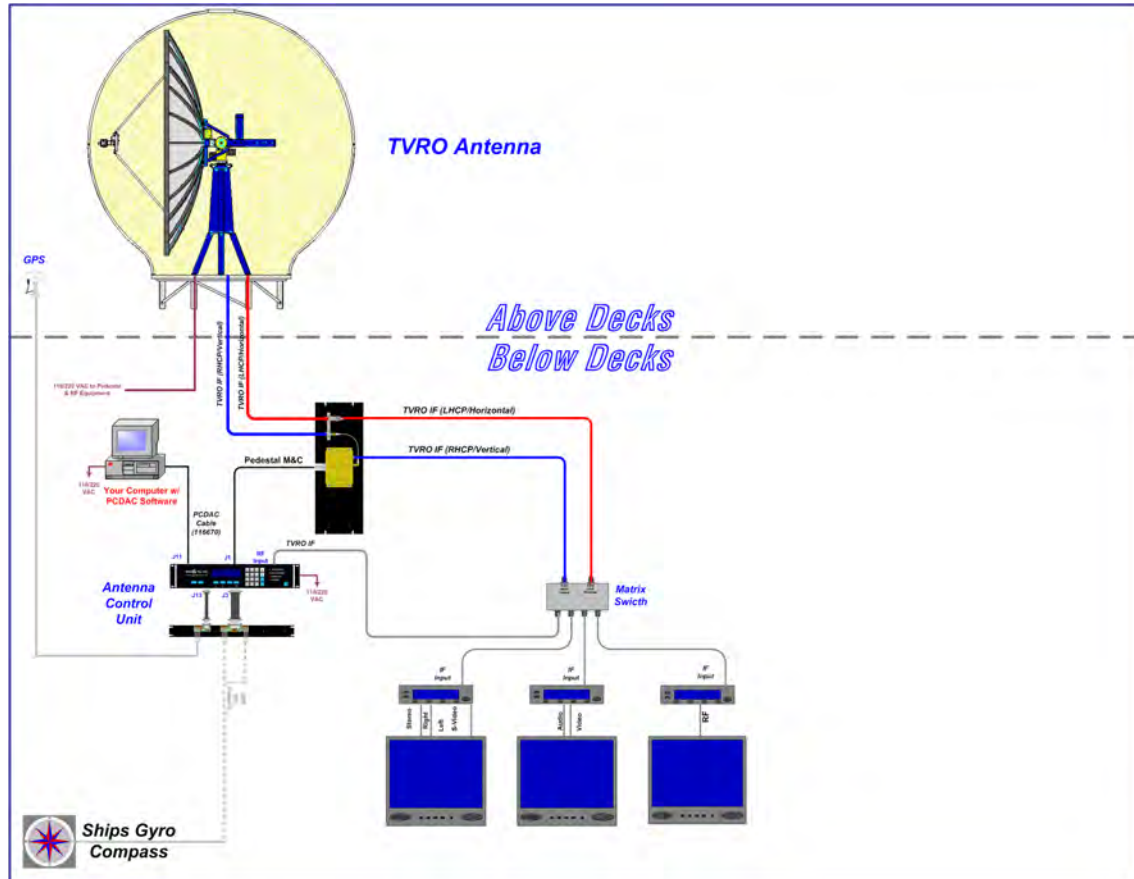

Figure 1-1 Series 00 TVRO Simplified Block Diagram

1.4. General scope of this manual

This manual describes the Sea Tel Series 00 Antenna (also called the Above Decks Equipment), its' operation and installation. Refer to the manual provided with your Antenna Control Unit for its' installation and operating instructions.

1.5. Quick Overview of contents

The information in this manual is organized into chapters. Operation, basic system information, installation, setup, functional testing, maintenance, specifications and drawings relating to this Antenna are all contained in this manual

2. Operation

2.1. System Power-up

Turn the Power switch on the louvered panel of the antenna pedestal ON. This will energize the antenna pedestal and the associated RF equipment.

Turn the Power switch on rear panel of the Antenna Control Unit (ACU) ON.

2.1. Antenna Initialization

A functional operation check can be made on the antenna stabilization system by observing its behavior during the 4 phases of initialization.

Turn the pedestal power supply ON. The PCU will initialize the stabilized portion of the mass to be level with the horizon and at a prescribed Azimuth and Elevation angles. The antenna will go through the specific sequence of steps (listed below) to initialize the antenna. These phases initialize the level cage, elevation, cross-level and azimuth to predetermined starting positions.

Initialization is completed in the following phases, each phase must complete properly for the antenna to operate properly (post-initialization).

1. Level Cage is driven CCW, issuing extra steps to assure that the cage is all the way to the mechanical stop. Then the Level cage will be driven exactly 45.0 degrees CW.
2. Elevation axis activates - Input from the LV axis of the tilt sensor is used to drive the Elevation of the equipment frame to bring the tilt sensor LV axis to level (this results in the dish being at an elevation angle of 45.0 degrees).
3. Cross-Level axis activates - Input from the CL axis of the tilt sensor is used to drive Cross-Level of the equipment frame to bring the cross-level axis of the tilt sensor to level (this results in the tilt of the Cross-Level Beam being level).
4. Azimuth axis activates - Antenna drives in azimuth until the "Home Flag" signal is produced. This signal is produced by a Home Switch hitting a cam or by a Hall Effect sensor in close proximity to a Magnet.

This completes the phases of initialization. At this time the antenna elevation should 45.0 degrees and Relative azimuth should be at be at home flag (home switch engaged on the home flag cam).

If any of these steps fail, or the Antenna Control Unit reports model number as "xx97" re-configure the PCU as described in section the Setup section of this manual. If initialization still fails, refer to the troubleshooting section of this manual.

2.2. Antenna Stabilization

After initialization has completed, real-time stabilization of the antenna is an automatic function of the PCU.

2.3. Stabilized Pedestal Assembly Operation

Operation of the stabilized antenna Pedestal Control Unit (PCU) is accomplished remotely by the Antenna Control Unit (ACU). Refer to the Operation section of the Antenna Control Unit manual for more specific operation details. There are no other operating instructions applicable to the pedestal assembly by itself.

2.4. Tracking Operation

Tracking optimizes the antenna pointing, in very fine step increments, to maximize the level of the satellite signal being received. The mode of tracking used in this antenna is a variation of Conical Scanning called DishScan.

DishScan continuously drives the antenna in a very small circular pattern at 60 RPM. The ACU evaluates the received signal throughout each rotation to determine where the strongest signal level is (Up, Right, Down or Left) and issues the appropriate Azimuth and/or Elevation steps to the antenna, as needed.

You cannot control tracking from the pedestal itself. Refer to the ACU manual for tracking operation information.

2.5. Antenna Polarization Operation

Linear feeds are equipped with a polarization motor and potentiometer feedback and are controlled from the Antenna Control Unit. Auto-Polarization mode is the default polarization mode of operation from the ACU. Polarization may be operated manually from the ACU for diagnostic or alignment purposes. Refer to the Antenna Control Unit manual for more operation information.

2.6. Low Noise Block Converter Operation

There are no operating instructions or controls applicable to the LNB. This unit is energized whenever the matrix switch and satellite receiver(s) have AC power connected to them.

Satellite signals are either circular polarized (spiraling plane down from the satellite) or linear polarized (fixed plane down from the satellite). The pedestal will receive circular polarization signals when a circular LNB is installed on the back of the dish. Conversely, the pedestal will only receive linear polarized signals when a linear LNB is installed.

2.7. Radome Assembly Operation

When operating the system it is necessary that the radome access hatch (and/or side door) be closed and secured in place at all times. This prevents rain, salt water and wind from entering the radome. Water and excessive condensation promote rust & corrosion of the antenna pedestal. Wind gusts will disturb the antenna pointing.

There are no other operating instructions applicable to the radome assembly by itself.

3. Basic System Information

This section provides you with some additional information about the satellites you will be using, basics of your Series antenna system and some of the other equipment within your system configuration.

3.1. *Satellite Basics*

The satellites are in orbit at an altitude of 22,754 miles and are positioned directly above the equator. Their orbital velocity matches the Earth's rotational speed, therefore, each appears to remain at a fixed position in the sky (as viewed from your location).

Your antenna can be used with any of the satellites in this orbit that have a strong enough receive signal level. Your antenna is capable of being fitted with a Linear or Circular feed assembly. The feed may be designed to operate at C-Band frequencies, Ku-Band frequencies or be capable of operation in both bands. With the correct feed assembly you will be able to receive the linear or circular signal at the specific frequency range of the desired satellite.

3.1.1. **Ku-Band Receive Frequency (10.95-12.75GHz)**

At these frequencies the signal from the satellite travels only in a straight line and is affected by weather changes in the atmosphere. There are several conditions that can cause a temporary loss of satellite signal, even within an area where the signal level is known to be adequate. The most common of these *normal* temporary losses are **blockage** and **rain fade**. They will interrupt services only as long as the cause of the loss persists.

3.1.2. **Blockage**

Blockage is loss due to an object in the path of the signal from the satellite to the dish. If an object that is large and dense is positioned in the path of the signal from the satellite, it will prevent sufficient signal from arriving at the dish. The signal can not bend around, or penetrate through, these objects and the reception will be degraded or completely interrupted. The dish is actively driven to remain pointed at the satellite (toward the equator) so, as the ship turns a mast or raised structure of your ship may become positioned between the satellite and the dish. Blockage may also be caused by anything standing near the radome, tall mountains, buildings, bridges, cranes or other larger ships near your ship. Moving or rotating the ship to position the antenna where it has an unobstructed view to the desired satellite will restore the antennas' ability to receive the satellite signal.

3.1.3. **Rain Fade**

Atmospheric conditions that may cause sufficient loss of signal level include rain, snow, heavy fog and some solar activities (sun spot and flare activity). The most common of these is referred to as "rain fade". Rain drops in the atmosphere reduce the signal from the satellite. The heavier the rain the higher the amount of signal loss. When the amount of loss is high enough, the antenna will not be able to stay locked onto the satellite signal. When the amount of rain has decreased sufficiently, the antenna will re-acquire the satellite signal. In a strong signal area, rain fall of about four inches per hour will cause complete loss of signal. In weaker signal areas the effects would be more pronounced.

3.1.4. **Signal level**

The level of the receive signal is dependant upon how powerful the transmission is, how wide the signal beam is, and what the coverage area is. Focusing the signal into a narrower beam concentrates its energy over a smaller geographic area, thereby increasing the signal level throughout that area of coverage. This makes it possible for you to use a smaller antenna size to receive that satellite signal. The antenna system must be geographically located in an area where the signal level from the satellite meets (or exceeds) the minimum satellite signal level required for your size of antenna (refer to the Specifications section of this manual) to provide suitable reception. This limits the number of satellites that can be used and the geographic areas where the ship can travel where the signal level is expected to be strong enough to continue providing uninterrupted reception. When traveling outside this minimum signal coverage area, it is normal for the system to experience an interruption in its ability to provide the desired satellite services until entering (or re-entering) an area of adequate signal level.

3.1.5. Satellite Footprints

The focused beam(s) from the satellites are normally aimed at the major land masses where there are large population centers. Footprint charts graphically display the signal level expected to be received in different geographic locations within the area of coverage. The signal will always be strongest in the center of the coverage area and weaker out toward the outer edges of the pattern. The coverage areas are intended to be a guide to reception, however, the actual coverage area and signal level and vary. Also the signal strength is affected by weather.

3.1.6. Linear Satellite polarization

Satellites may transmit their signals in one of two different polarization modes. The feed installed on your antenna must be designed to operate with linear polarized satellite transmissions.

Circular polarized satellite transmissions do not require polarization adjustment to optimize the reception.

Linear polarized satellite transmissions require periodic adjustment of "polarization" to optimize the alignment of the LNB to the angle of the signal from the satellite.

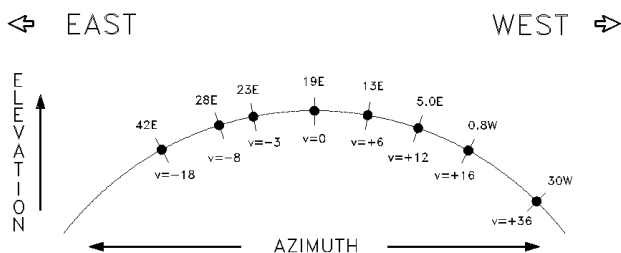

Figure 3-1 Satellite Signal Polarization

When you are at the same longitude as the satellite, its' horizontal and vertical signals will be aligned to your local horizon. When you are east or west of the satellite, the signals will appear to be rotated clockwise or counter-clockwise from your local horizontal and vertical. Both horizontal and vertical signals from a satellite will appear to be rotated the same amount and are always perpendicular to each other. The amount of rotation is dependent on how far east or west you are form the satellite and how close you are to the Equator.

3.2. Antenna Basics

The following information is provided to explain some of the basic functions of the antenna:

3.2.1. Unlimited Azimuth

Azimuth rotation of the antenna is unlimited (no mechanical stops). Azimuth drive, provided by the azimuth motor, is required during stabilization, searching and tracking operations of the antenna. When the ship turns, azimuth is driven in the opposite direction to remain pointed at the satellite. The actual azimuth pointing angle to the satellite is determined by your latitude & longitude and the longitude of the satellite. It is important to know that the antenna should be pointed (generally) toward the equator.

The azimuth angle to the satellite would be 180 degrees true (relative to true north) if the satellite is on the same longitude that you are on. If the satellite is east, or west, of your longitude the azimuth will be less than, or greater than 180 degrees respectively.

When checking for blockage you can visually look over the antenna radome toward the equator to see if any objects are in that sighted area. If you are not able to find any satellites it may also be useful to remove the radome hatch to visually see if the dish is aimed the correct direction (towards the equator).

3.2.2. Elevation

In normal operation the elevation of the antenna will be between 00.0 (horizon) and 90.0 (zenith). The antenna can physically be rotated in elevation below horizon and beyond zenith to allow for ship motion. Elevation drive, provided by the elevation motor, is required during stabilization, searching and tracking operations of the antenna. The actual elevation pointing angle to the satellite is determined by your latitude & longitude and the longitude of the satellite. In general terms the elevation angle will be low when you are at a high latitudes and will increase as you get closer to the equator.

Additionally, from any given latitude, the elevation will be highest when the satellite is at the same longitude that you are on. If the satellite is east, or west, of your longitude the elevation angle will be lower.

3.2.3. Feed Assembly

The scalar section of the feed is fitted with a polarization motor and a potentiometer for position feedback required for linear signal operation. The feed may be fitted for Linear or Circular reception. The appropriate LNA, LNB or LNC must be installed on the Linear or Circular section of the feed to receive the frequencies of the desired satellite.

When a Linear feed is installed, the ACU automatically adjusts the feed by remotely controlling the 24 volt DC motor, using the potentiometer feedback for Linear polarization position (Auto-Polarization mode).

When a Circular feed is installed, no polarization adjustment is required because the circular feed receives the signal properly regardless of its polarization position.

The feed may be dual band (C-Band and Ku-Band) allowing you to use either band. The Tracking - Band Selection remotely controls coax switches mounted on the antenna pedestal to select which LNB outputs are routed through the antenna pedestal to the Below Decks Equipment.

3.2.4. Antenna polarization

You have a linear polarization feed installed, the system should have been adjusted properly and set-up to operate in Auto-Polarization mode. The ACU will then automatically adjust the polarization of the feed, as necessary, while the ship travels in Latitude and Longitude.

3.2.5. Stabilization

Your antenna is stabilized in all three axes of motion. Stabilization is the process of de-coupling the ships' motion from the antenna. Simply put, this allows the antenna to remain pointed at a point in space while the boat turns, rolls or pitches under it. To accomplish this, the Pedestal Control Unit (PCU) on the antenna pedestal assembly senses the motion and applies drive to the appropriate motor(s) in opposition to the sensed motion. Azimuth (AZ), Elevation (EL) and Cross-Level (left-right tilt) are actively stabilized automatically by the PCU as part of its normal operation.

3.2.6. Search Pattern

Whenever the desired satellite signal is lost (such as when the antenna is blocked) the Antenna Control Unit will automatically initiated a Search to re-acquire the desired signal.

Search is conducted in a two-axis pattern consisting of alternate movements in azimuth and elevation. The size and direction of the movements are increased and reversed every other time resulting in an expanding square pattern.

When the antenna is able to re-acquire the desired signal the ACU will automatically stop searching and begin Tracking the signal to optimize the pointing of the antenna to get the highest signal level from the satellite.

3.2.7. Tracking Receiver - Satellite Identification Receiver

The Satellite Identification Receiver located in the Antenna Control Unit (ACU) is used to acquire, identify and track a specific satellite by its unique hexadecimal ID code. When properly setup, the settings for the satellite are saved to expedite future acquisition of the desired satellite.

When searching for the selected satellite this receiver compares the present satellite ID to the targeted satellite ID code. If the ID code does not match the antenna will continue searching until the correct satellite is found. The system must have adequate satellite signal level, AND the matching NID, to stop searching (and begin tracking the desired satellite).

3.2.8. Tracking

Your Antenna Control Unit actively optimizes the pointing of the dish for maximum signal reception. This process is called **tracking** and is accomplished by continuously making small movements of the dish while monitoring the level of the received signal. Evaluation of this information is used to continuously move the stabilization point toward peak satellite signal reception. These minor pointing corrections keep the signal level "peaked" as part of normal operation.

3.3. Components of the System Configuration

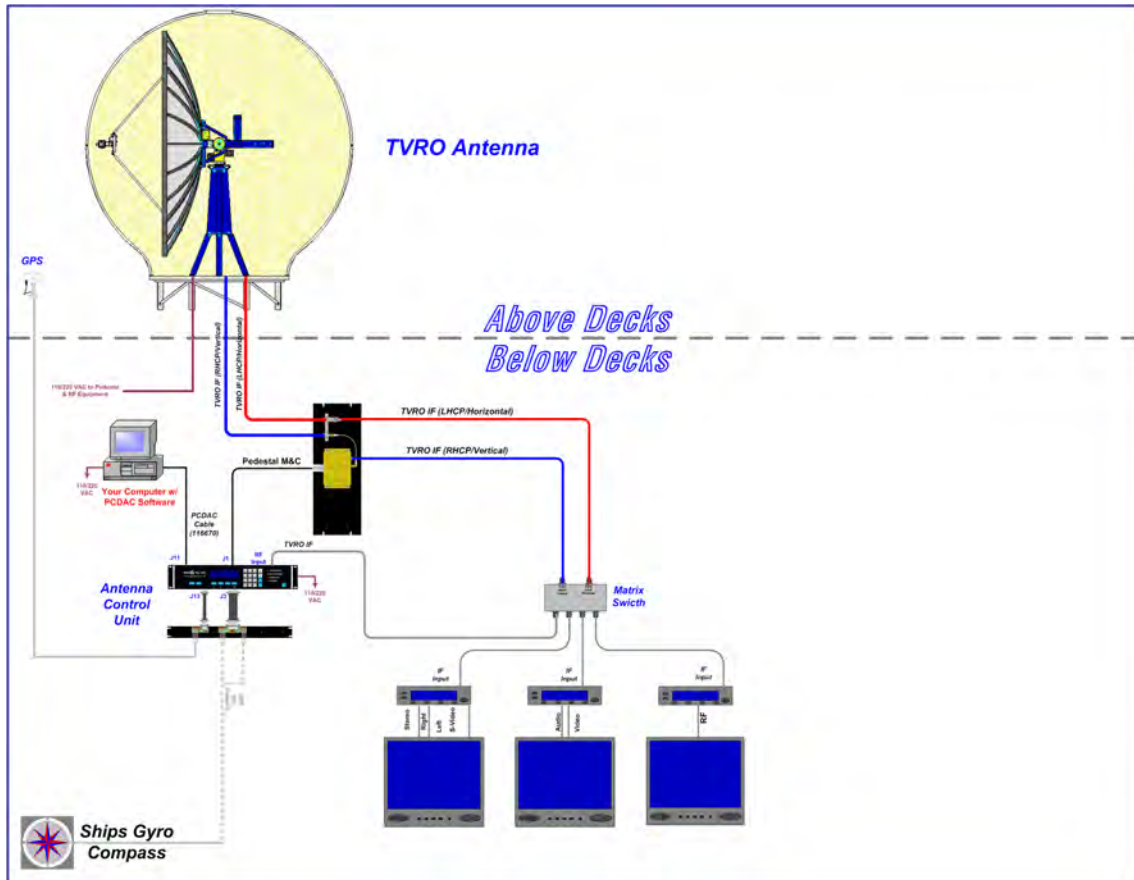

Figure 3-2 Series 00 TVRO Simplified Block Diagram

The following text provides a basic functional overview of the system components and component interconnection as referred to in the simplified block diagram for your Series 00 antenna. Also, refer to the appropriate page of the System Block Diagram which depicts your system configuration.

3.3.1. Antenna ADE Assembly

The Above Decks Equipment consists of an Antenna Pedestal inside a Radome assembly. The pedestal consists of a satellite antenna dish & feed with a linear, or a circular Low Noise Block converter (LNB) with polarization motor mounted on a stabilized antenna pedestal. The radome provides an environmental enclosure for the antenna pedestal assembly inside it. This keeps wind, water condensation and salt-water spray off the antenna pedestal assembly. This prevents damage and corrosion that would shorten the expected life span of the equipment.

The antenna control cable is connected between the antenna radome assembly and the antenna control panel. This cable provides DC voltage to the antenna and all control signals to and from the antenna.

Six RG-6 (or better) coax cables are connected from the antenna radome assembly to the below decks equipment. One of these cables is the Antenna Control Cable, which has the DC operating voltage for the antenna and the antenna control communication between the Antenna Control Unit and the Pedestal Control Unit. Four cables carry the intermediate frequency (950-2050MHz) signals from the antenna assembly directly to the matrix switch and the DC Voltage & Tone switching from the Matrix Switch to the LNB. All four are provided, even if you are only currently using two for the LNB you presently have installed on your antenna. These cables ultimately provide the input signal into the satellite receiver(s). And finally, one coax is installed as a spare.

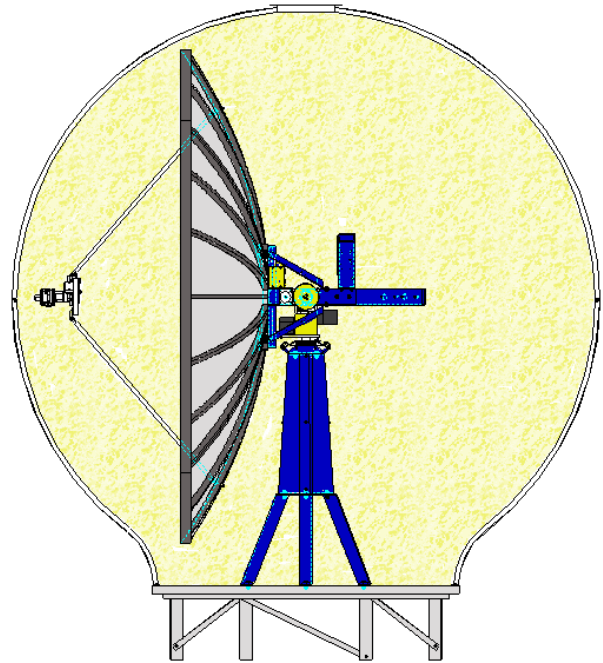

Figure 3-3 Series 97 TVRO Above Decks Equipment

3.3.2. Antenna Control Unit

The Antenna Control Unit allows the operator to control and monitor the antenna pedestal with dedicated function buttons, LED's and a 2 line display. The ACU and its Terminal Mounting Strip are normally mounted in a standard 19" equipment rack. The ACU should be mounted in the front of the equipment rack where it is easily accessible. The Terminal Mounting Strip is normally mounted on the rear of the equipment rack. It is recommended that the antenna control unit be mounted near the Satellite modem location where you can see the LED indicators while you are controlling the antenna.

The Antenna Control Unit is connected to the antenna, ships Gyro Compass and Satellite modem.



Figure 3-4 Antenna Control Unit

The Antenna Control Unit (ACU) communicates via an RS-422 full duplex data link with the Pedestal Control Unit (PCU) located on the antenna. This control signal to/from the antenna is on the Coax cable along with the 24VDC Pedestal power. The Pedestal Control Unit stabilizes the antenna against the ship's roll, pitch, and turning motions. The ACU is the operator interface to the PCU and provides the user with a choice of positioning commands to point the antenna, search commands to find the satellite signal and tracking functions to maintain optimum pointing angle. The operator may choose to work from either the front panel, using the M&C Port in conjunction with DacRemP remote diagnostic software, or the built in Ethernet port and a internal HTML page using a standard internet browser.

3.3.3. Above Decks AC Power Supply

Pedestal Power - An appropriate source of AC Voltage (110 VAC 60 Hz OR 220 VAC 50 Hz) is required for the above decks equipment. Refer to the Specifications section of this manual for the power consumption of the antenna pedestal.

3.3.4. Satellite Receivers

The TVRO Antenna system, with the appropriate LNB installed, can be used with standard European satellite receivers, and Integrated Receiver-Decoders (IRD). Both can receive "free" programming, but an IRD is required when the desired programming is encrypted. When authorized, it will decode the encrypted signals for use. Authorizing the receiver-decoder is a process of registering your receiver(s) and paying subscription fees to the service provider. The service provider then arranges for a signal to be sent through the satellite to your receiver-decoder, which will "enable" it to decode the programming you subscribed to.

A coax connection from the antenna (via the matrix switch) provides signal input to the receiver. The receiver also outputs voltage and tone control to the matrix switch to select the correct band and polarization signal for the channel you want to watch. A coax connection from the TV OUTPUT jack on the satellite receiver is connected to the ANTENNA INPUT on the television. Alternately, individual audio/video, Audio & S-Video, or SCART cable connections may be made between the satellite receiver and the television.

3.3.5. Television/Monitor

An appropriate television monitor is used to view the satellite television programming and to view the on screen displays from the receiver.

3.3.6. Matrix Switch



A matrix switch must be installed with all of the antenna IF coax cables connected to its' LNB inputs. A coax cable (RG-6 OR greater) is connected from each matrix switch output to each satellite receiver. Sea Tel recommends that an ACTIVE Matrix be used in all installations. Matrix switches with 4, 8, 12 and 16 outputs are available.

Each of the outputs can be connected to a satellite receiver, one of these outputs must be connected the tracking receiver in the ACU. Each output of the matrix switch is controlled by voltage, and/or tone, from the satellite connected to that output connector. This voltage, and/or tone, selects which of the input signals gets routed to that output connector, therefore, to that receiver. Each output of the matrix switch operates independently of the others, therefore, allows the satellite receivers to operate independently also. As you change channels on the satellite receiver, it uses the voltage, and/or tone, to select the correct signal input for the channel you have selected.

4. Installation

This section contains instructions for unpacking, final assembly and installation of the equipment. It is highly recommended that final assembly and installation of the Antenna system be performed by trained technicians. Read this complete section before starting.

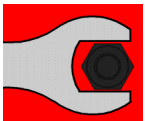
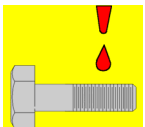
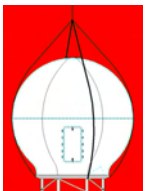
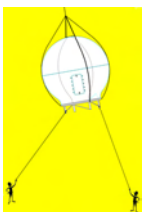
4.1. General Cautions & Warnings

	<p>WARNING: Assure that all nut & bolt assemblies are tightened according the tightening torque values listed below:</p> <table border="1" data-bbox="516 617 1230 842"> <thead> <tr> <th>Bolt Size</th> <th>Inch Pounds</th> </tr> </thead> <tbody> <tr> <td>1/4-20</td> <td>75</td> </tr> <tr> <td>5/16-18</td> <td>132</td> </tr> <tr> <td>3/8-16</td> <td>236</td> </tr> <tr> <td>1/2-13</td> <td>517</td> </tr> </tbody> </table>	Bolt Size	Inch Pounds	1/4-20	75	5/16-18	132	3/8-16	236	1/2-13	517		
Bolt Size	Inch Pounds												
1/4-20	75												
5/16-18	132												
3/8-16	236												
1/2-13	517												
	<p>NOTE: All nuts and bolts should be assembled using the appropriate Loctite thread-locker product number for the thread size of the hardware.</p> <table border="1" data-bbox="516 932 1230 1199"> <thead> <tr> <th>Loctite #</th> <th>Description</th> </tr> </thead> <tbody> <tr> <td>222</td> <td>Low strength for small fasteners.</td> </tr> <tr> <td>243</td> <td>Medium strength, oil tolerant.</td> </tr> <tr> <td>680</td> <td>High strength for Motor Shafts & Sprockets.</td> </tr> <tr> <td>271</td> <td>Permanent strength for up to 1" diameter fasteners.</td> </tr> <tr> <td>290</td> <td>Wicking, High strength for fasteners which are already assembled.</td> </tr> </tbody> </table>	Loctite #	Description	222	Low strength for small fasteners.	243	Medium strength, oil tolerant.	680	High strength for Motor Shafts & Sprockets.	271	Permanent strength for up to 1" diameter fasteners.	290	Wicking, High strength for fasteners which are already assembled.
Loctite #	Description												
222	Low strength for small fasteners.												
243	Medium strength, oil tolerant.												
680	High strength for Motor Shafts & Sprockets.												
271	Permanent strength for up to 1" diameter fasteners.												
290	Wicking, High strength for fasteners which are already assembled.												
	<p>WARNING: Hoisting with other than a webbed four-part sling may result in catastrophic crushing of the radome. Refer to the specifications and drawings for the fully assembled weight of your model Antenna/Radome and assure that equipment used to lift/hoist this system is rated accordingly.</p>												
	<p>CAUTION: The antenna/radome assembly is very light for its size and is subject to large swaying motions if hoisted under windy conditions. Always ensure that tag lines, attached to the radome base frame, are attended while the antenna assembly is being hoisted to its assigned location aboard ship.</p>												
	<p>WARNING: Electrical Hazard – Dangerous AC Voltages exist inside the Antenna Pedestal Breaker Box. Observe proper safety precautions when working inside the Pedestal Breaker Box.</p>												
	<p>WARNING: Electrical Hazard – Dangerous AC Voltages exists on the side of the Antenna Pedestal Power Supply. Observe proper safety precautions when working inside the Pedestal Power Supply.</p>												

4.2. **Site Survey**

The radome assembly should be installed at a location aboard ship where:

1. The antenna has a clear line-of-sight to as much of the sky (horizon to zenith at all bearings) as is practical.
2. Direct radiation into the antenna from ships radar, especially high power surveillance radar arrays, is minimized. The radome should be as far away from the ships Radar as possible and should NOT be mounted on the same plane as the ships Radar (so that it is not directly in the Radar beam path).
3. The radome should be as far away from the ships high power short wave (MF & HF) transmitting antennas as possible.
4. The Above Decks Equipment (ADE) and the Below Decks Equipment (BDE) should be positioned as close to one another as possible. This is necessary to reduce the losses associated with long cable runs.
5. The mounting location is rigid enough that it will not flex, or sway, in ships motion or vibration. If the radome is to be mounted on a raised pedestal, it **MUST** have adequate gussets, or be well guyed, to prevent flexing or swaying in ships motion.

If these conditions cannot be entirely satisfied, the site selection will inevitably be a “best” compromise between the various considerations.

4.3. **Preparing For The Installation**

4.3.1. **Unpack Shipping Crates**

Exercise caution when unpacking the equipment.

4.3.2. **Inspect / Inventory**

Carefully inspect the radome panel surfaces for evidence of shipping damage. Inspect the pedestal assembly and reflector for signs of shipping damage.

4.3.3. **Prepare ADE Mounting Location**

Prepare the mounting location for the Radome. If the radome is to be bolted to the deck (or a platform) assure that the mounting holes have been drilled. Assure that the mounting hardware has obtained and is readily available.

4.3.4. **Preparing BDE Location**

Prepare the mounting location for the Below Decks Equipment. These equipments would normally be installed in a standard 19” equipment rack. Refer to the Antenna Control Unit manual for installation of the ACU and the Terminal Mounting Strip.

Refer to the vendor supplied manuals for installation of the other below decks equipments.

Prepare other locations throughout ship for any other equipment which is not co-located with the ACU.

4.3.5. **Installing The System Cables**

Install appropriate cables from Below Decks Equipment to the ADE Location(s).

The cables must be routed from the above-decks equipment group through the deck and through various ship spaces to the vicinity of the below-decks equipment group. When pulling the cables in place, avoid the use of excessive force. Exercise caution during the cable installation to assure that the cables are not severely bent (proper bend radius), kinked or twisted and that connectors are not damaged.

Assure that the cables have been run through watertight fittings and/or will not permit water entry into the ship when the installation is completed. After cables have been routed and adjusted for correct cable length at each end, seal the deck penetration glands and tie the cables securely in place.

4.4. **Assembling the ADE**

The assembly procedure described below begins by sub-assembling sections of the baseframe, radome and pedestal. Then these are assembled to form the ADE.

4.4.1. **144” Radome, Baseframe and Antenna Pedestal System Assembly**

Refer to the System Block diagram, General Assembly, Radome Assembly and Baseframe Assembly drawings for your system.



NOTE: Unless otherwise indicated, all nuts and bolts should be assembled with Loctite 271 or its equivalent.

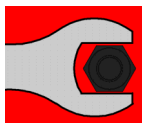

WARNING: Assure that all nut & bolt assemblies are tightened according the tightening torque values listed below:

Bolt Size	Inch Pounds
1/4-20	75
5/16-18	132
3/8-16	236
1/2-13	517

1. Select a secure assembly site that provides enough area to work with the large radome panels. Place the radome base pan on temporary support blocks at least 22 inches high.
2. Assemble the radome base frames eight legs and eight braces using the hardware provided. Loosely assemble all legs and braces aligning all matching marks before tightening any of the bolts. Insure that a split washer is used under each nut.
3. Refer to the radome assembly drawing. Observe the painted numbers on the radome panels that clearly identify their positions respective to each other and the base pan assembly.
4. Loosely assemble the 6 lower side panels, using the hardware provided, to form the bottom half of the radome. Do NOT tighten the bolts at this time. Open each seam wide enough to install a good bead of silicone caulk, then firmly tighten all the bolts in that flange. Repeat until all flanges are sealed.
5. Loosely assemble the 6 upper side panels, using the hardware provided, to form the upper half of the radome. Do NOT tighten the bolts at this time. Open each seam wide enough to install a good bead of silicone caulk, then firmly tighten all the bolts in that flange. Repeat until all flanges are sealed.
6. Apply a good bead of silicone caulk all the way around the top cap. Install the cap into the upper radome panel assembly using the hardware provided and tighten all the bolts.
7. Set the lower half of the radome assembly on the base pan aligning the painted numbers on the radome panels. Loosely attach the lower side panel assembly to the base frame using the hardware provided. Do NOT tighten the bolts at this time. Lift the lower side panel assembly wide enough to install a good bead of silicone caulk between it and the base pan, then firmly tighten all the bolts.
8. Fasten the antenna pedestal assembly, complete with base stand, to the base pan using the 1/2-13 x 1 1/2 (or the 3/8-16 x 1 1/2) inch bolts inserted from the bottom up and install a flat washer, a lock washer and a nut in each mounting hole. Apply Loctite 271 and tighten securely.
9. Attach the antenna assembly (reflector, struts and feed) to the stabilized pedestal, by using the reflector mounting hardware provided. Position the antenna over the four antenna support struts (the antenna and the dish mounting clips are numbered or color coded make sure they match). Insert the four mounting bolts, washers and nuts, apply Loctite 271 and tighten.
10. Attach the 15 pin connector on the antenna reflector harness to the shielded Polang Aux Relay box. Connect the IF receive coax cables from the feed to the pedestal Modem or coax relay/switch panel according to the block diagram.
11. Using a four point web lifting sling and lifting clips, lift the upper half of the radome up over the antenna pedestal and set it onto the lower side panels aligning the painted numbers on the radome panels. Loosely attach the upper and lower halves of the radome using the hardware provided. Do NOT tighten the bolts at this time. Insert wedges between the upper side panel assembly and the lower side panel assembly to hold open a space wide enough to install a good bead of silicone caulk between it and the lower side panels, then remove the wedges and firmly tighten all the bolts.
12. Gently restrain the antenna prior to lifting the ADE onto the ship to restrict movement inside the radome during the lift.

4.4.2. Preparing the ADE for Lift

Install Stow Braces, or other restraints, on the Antenna Pedestal. Attach shackles and web type lifting harness to the four lifting holes in the base-frame.

4.5. Installing The ADE

4.5.1. Hoist

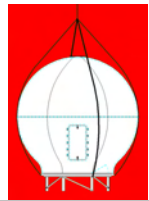
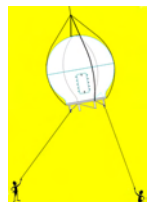
	<p>WARNING: Hoisting with other than a webbed four-part sling may result in catastrophic crushing of the radome. Refer to the specifications and drawings for the fully assembled weight of your model Antenna/Radome and assure that equipment used to lift/hoist this system is rated accordingly.</p>
	<p>CAUTION: The antenna/radome assembly is very light for its size and is subject to large swaying motions if hoisted under windy conditions. Always ensure that tag lines, attached to the radome base frame, are attended while the antenna assembly is being hoisted to its assigned location aboard ship.</p>

1. Assure that the antenna is restrained before hoisting. Check that all nuts on the base frame assembly are tightened according the torque values listed below:
2. Using a four-part lifting sling, and with a tag line attached to the radome base frame, hoist the antenna assembly to its assigned location aboard ship by means of a suitably-sized crane or derrick.
3. The radome assembly should be positioned with the BOW marker aligned as close as possible to the ship centerline. Any variation from actual alignment can be compensated with the AZIMUTH TRIM adjustment in the ACU, so precise alignment is not required.

4.5.2. Install Antenna/Radome/Baseframe

Bolt, or weld, the legs of the radome base frame directly to the ship's deck. If the deck is uneven or not level, weld clips to the deck and attach them to the legs of the radome base frame. When completed the radome base must be level.

4.6. Install BDE Equipment

4.6.1. ACU & TMS

Refer to the Antenna Control Unit manual for installation of the ACU and the Terminal Mounting Strip.

4.6.2. Other BDE Equipment

Refer to the vendor supplied manuals for installation of the other below decks equipment.

4.7. Cable Terminations

4.7.1. At The Radome

The TX and RX, or TVRO IF, cables must be inserted through the cable strain reliefs at the base of the radome. Apply RTV to the strain relief joints and tighten the compression fittings to make them watertight. Attach the pedestal cable adapters to the TX and RX, or TVRO IF, cables from below decks. Refer to the System Block Diagram.

AC Power cable for the Antenna Pedestal and RF Equipment is routed into the AC Power Breaker box and connected to the breaker terminals.

Sea Tel recommends that separate, dedicated, AC Power be provided for the Marine Air Conditioner (Do NOT combine with the AC Power provided for the Antenna Pedestal and RF Equipment). This AC Power cable is routed into the Marine Air Conditioner and terminated to the AC terminals inside.

4.7.2. ACU & TMS

To Connect AC Power, Gyro Compass Connection and IF Input refer to the Antenna Control Unit manual. Installation of optional (remote) Pedestal, and /or Radio, Monitor & Control connection(s) from a PC Computer are also contained in the ACU manual.

4.7.3. Other BDE Equipment

Refer to the vendor supplied manuals for installation of the other below decks equipment.

4.8. Final Assembly

4.8.1. Remove Stow Braces/Restraints

Remove the restraints from the antenna and verify that the antenna moves freely in azimuth, elevation, and cross level without hitting any flanges on the radome.

4.8.2. Verify all assembly and Wiring connections

Verify that all pedestal wiring and cabling is properly dressed and clamped in place.

4.8.3. Balance Antenna Pedestal

Assure that the antenna assembly is balanced front to back, top to bottom and side to side by observing that it remains stationary when positioned in any orientation. Refer to the Maintenance section for complete information on balancing the antenna.

4.9. Power-Up The ADE

Turn Pedestal AC power breaker ON.

4.9.1. Initialization

Turn the pedestal power supply ON. The PCU will initialize the stabilized portion of the mass to be level with the horizon and at a prescribed Azimuth and Elevation angles. The antenna will go through the specific sequence of steps to initialize the level cage, elevation, cross-level and azimuth to predetermined starting positions. Each phase must complete properly for the antenna to operate properly (post-initialization). Refer to the initialization text in the Troubleshooting section in this manual. Observe the Initialization of the antenna pedestal.

If any of these steps fail, or the ACU reports model "xx97", re-configure the PCU as described in the Setup section of this manual. If initialization still fails, this indicates a drive or sensor problem, refer to the Troubleshooting section.

4.9.2. Home Flag Position

Note the approximate position of the antenna relative to the bow of the ship while it is at the home switch position. This information will be used later to calibrate the relative position display of the antenna.

4.9.3. BDE

Turn Power ON to the ACU. Record the power-up display, Master (ACU) Model & Software version and the Remote (PCU) Model & Software version.

4.10. Setup

Refer to the Setup information in the next section of this manual and in the Setup section of your ACU Manual.

This Page Intentionally Left Blank

5. Setup

Below are basic steps to guide you in setting up the ACU for your specific antenna pedestal. Assure that the Antenna Pedestal (ADE) has been properly installed before proceeding. Refer to the Setup section of your ACU manual for additional parameter setting details.

5.1. Operator Settings

Refer to the Operation chapter of this manual to set the Ship information. Latitude and Longitude should automatically update when the GPS engine mounted above decks triangulates an accurate location, but you may enter this information manually to begin. If your gyro source is providing Heading information in any format other than NMEA-0183 format, you will have to enter in the initial Ship's Heading position, the Gyro Compass will then keep the ACU updated.

Set the Satellite information, for the satellite you will be using. The receiver settings are especially important. At this point you should be able to target the desired satellite. Continue with the setup steps below to optimize the parameters for your installation.

5.2. Optimizing Targeting

First, assure that all of your Ship & Satellite settings in the ACU are correct. Target the desired satellite, immediately turn Tracking OFF, and record the Azimuth and Elevation positions in the "**ANTENNA**" display of the ACU (these are the **Calculated** positions). Turn Tracking ON, allow the antenna to "Search" for the targeted satellite and assure that it has acquired (and peaks up on) the satellite that you targeted. Allow several minutes for the antenna to "peak" on the signal, and then record the Azimuth and Elevation positions while peaked on satellite (these are the **Peak** positions). Again, assure that it has acquired the satellite that you targeted!

Subtract the Peak Positions from the Calculated Positions to determine the amount of Trim which is required. Refer to the ACU Setup information to key in the required value of Elevation Trim. Continue with Azimuth trim, then re-target the satellite several times to verify that targeting is now driving the antenna to a position that is within +/- 1.0 degrees of where the satellite signal is located.

EXAMPLE: The ACU targets to an Elevation position of 30.0 degrees and an Azimuth position of 180.2 (Calculated), you find that Peak Elevation while ON your desired satellite is 31.5 degrees and Peak Azimuth is 178.0. You would enter an EL TRIM value of -1.5 degrees and an AZ TRIM of +2.2 degrees. After these trims values had been set, your peak **on satellite** Azimuth and Elevation displays would be very near 180.2 and 30.0 respectively.

5.3. Optimizing Auto-Polarization TVRO

If your system is fitted with a circular feed you do not need to optimize the polarity angle and can skip this procedure. This procedure optimizes the linear polarization of the feed. Verify that tracking is ON and that the antenna is peaked on your targeted satellite (targeting calculates the azimuth, elevation and polarization angles). Assure that you are in Auto-Pol mode (POL TYPE parameter in the ACU is set to 0072) and set one of your satellite receivers to view its signal level display. Go to the POL OFFSET parameter in the Setup menu of the ACU.

Default setting is 0030 and may be incremented, or decremented, to adjust polarization while in Auto-Pol mode. Each increment equals one degree of polarization rotation (0038 = +8 degrees), decrement below 30 for minus polarization (0022 = -8 degrees). Press the UP arrow to increment or the DOWN arrow to decrement the value and then hit the ENTER key to adjust the feed to the new value.

Adjust the polarization UP until you see the signal level on the receiver fall. Note the "high" offset value and adjust the offset DOWN until you see the signal peak and then begin to fall. Note this "low" offset value. Set POL OFFSET to a value that is mid-way between the high & low values you just observed. Save your new POL OFFSET value (refer to Save New Parameters in your ACU manual).

5.4. Calibrating Relative Antenna Position (Home Flag Offset)

During initialization, azimuth drives the CW antenna until the Home Switch is contacted, which "presets" the relative position counter to the value stored in the Home Flag Offset. This assures that the encoder input increments/decrements from this initialization value so that the encoder does not have to be precision aligned.

The Home Switch is a micro switch with a roller arm which is actuated by cam mounted on the azimuth driven sprocket, or it is a hall sensor which is actuated by a magnet mounted on the azimuth driven sprocket, which produces the "Home Flag" signal.

The Home Flag Offset is a value saved in NVRam (Non-Volatile RAM) in the PCU. This value is the relative position of the antenna when the home switch is engaged. Presetting the counter to this value assures that when the antenna is pointed in-line with the bow of the ship the counter will read 000.0 **Relative** (360.0 = 000.0).

In most cases when the antenna stops at the home flag, it will be pointed in-line with the Bow of the ship. In these cases Home Flag Offset (HFO) should be set to zero. When "Optimizing Targeting" small variations (up to +/- 5.0 degrees) in Azimuth can be corrected using If it AZ TRIM as described in the Optimizing Targeting procedure above.

Large variations in Azimuth position indicate that the Relative position is incorrect and should be "calibrated" using the correct HFO value instead of an Azimuth Trim offset. This is especially true if sector blockage mapping is used.

If the antenna stops at the home flag, but it is NOT pointed in-line with the Bow of the ship, it is important to assure that the antennas **actual** position (relative to the bow of the ship) is the value that gets "preset" into the Relative position counter. By saving the antennas **actual** Relative position when at the home flag into HFO, you have calibrated the antenna to the ship.

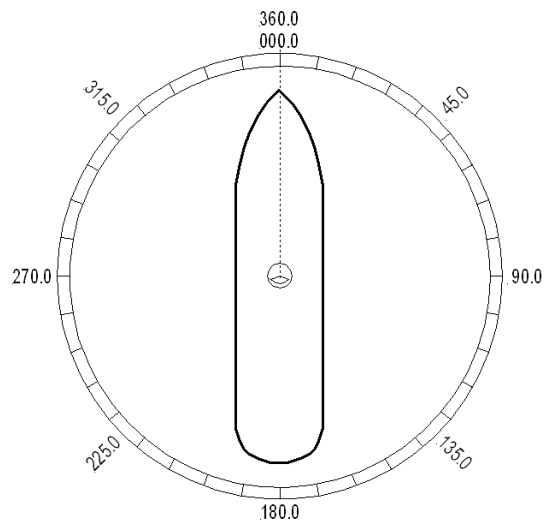

Figure 5-1 Antenna stops In-line with Bow

5.4.1. To Calculate HFO:

If Targeting has been optimized by entering a large value of AZ TRIM; First, verify that you are able to repeatedly accurately target a desired satellite (within +/- 1.0 degrees). Then you can use the AZ TRIM value to calculate the value of HFO you should use (so you can set AZ TRIM to zero). AZ Trim is entered as the number of **tenths** of degrees. You will have to convert the AZ TRIM value to the nearest **whole** degree (round up or down as needed). Calculated HFO value is also rounded to the nearest whole number.

If AZ TRIM was a **plus** value: $HFO = (TRIM / 360) \times 255$ Example: AZ TRIM was 0200 (plus 20 degrees). $HFO = (20/360) \times 255 = (0.0556) \times 255 = 14.16$ round off to 14.

If AZ TRIM was a **negative** value: $HFO = ((360-TRIM) / 360) \times 255$ Example: AZ TRIM = -0450 (minus 45 degrees). $HFO = ((360 - 45) / 360) \times 255 = (315 / 360) \times 255 = 0.875 \times 255 = 223.125$ round of to 223.

If Targeting has NOT been optimized, allow the antenna to initialize to its home flag position. Visually compare the antennas pointing to the bow-line of the ship (parallel to the Bow). Note the antennas position relative to the Bow. If it appears to be very close to being parallel to the bow, HFO will probably not be needed and you can proceed with Optimizing Targeting. If it is NOT close, initialization was driving the azimuth CW, note if the antenna appears to have stopped before it got to the Bow or if it went past the Bow. You may be able to guess an approximate amount of how many degrees the antenna is from the bow. This is only intended to help you initially find the satellite (which direction you will have to drive and approximately how far you will have to drive). Refer, in general terms, to the Optimizing Targeting procedure.

If the antenna stopped before it got to the bow-line; When you initially target a satellite, the antenna will also stop prior to the satellite position, so you that will have to drive the Azimuth of the antenna UP to actually find the satellite. Using the same basic procedure as in the Optimizing Targeting paragraph, target the satellite

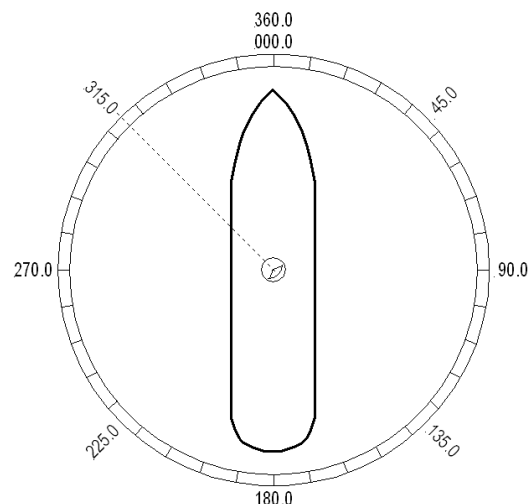

Figure 5-2 Antenna stopped before the Bow

and record the “Calculated” Azimuth position that the antenna was driven to. Drive UP until you find the satellite, positively identify that you are on **the satellite** you targeted and allow tracking to peak the antenna position. Record the “Peak” Azimuth position. Subtract the “Peak” position from the “Calculated” position to determine the number of degrees of AZ TRIM that would be required.

Example: In this new installation, I target my desired satellite and record the Calculated Azimuth to be 180.5. I drive UP and finally find my desired satellite at a Peak Azimuth of 227.0 degrees. I subtract Peak from Calculated and difference to be –46.5 degrees, therefore the actual Relative position that needs to be preset into the counter when the antenna is at the Home Flag is 313.5. $HFO = ((360-46.5) / 360) \times 255 = (313.5 / 360) \times 255 = 0.87 \times 255 = 222.06$ which I round down to 222.

If the antenna went past the bow-line; When you initially target a satellite, the antenna will also go past the satellite position, so that you will have to drive the Azimuth of the antenna DOWN to actually find the satellite.

Using the same basic procedure as in the Optimizing Targeting paragraph, target the satellite and record the “Calculated” Azimuth position that the antenna was driven to. Drive DOWN until you find the satellite, positively identify that you are on **the satellite** you targeted and allow tracking to peak the antenna position. Record the “Peak” Azimuth position. Subtract the “Peak” position from the “Calculated” position to determine the number of degrees of AZ TRIM that would be required. Refer to the

calculations above to determine the HFO you should use for this antenna.

Example: In this new installation, I target my desired satellite and record the Calculated Azimuth to be 180.0. I drive DOWN and finally find my desired satellite at a Peak Azimuth of 90.0 degrees. I subtract Peak from Calculated and difference to be +90.0 degrees, therefore the actual Relative position that needs to be preset into the counter when the antenna is at the Home Flag is 90.0. $HFO = ((90.0) / 360) \times 255 = 0.25 \times 255 = 63.75$ which I round up to 64.

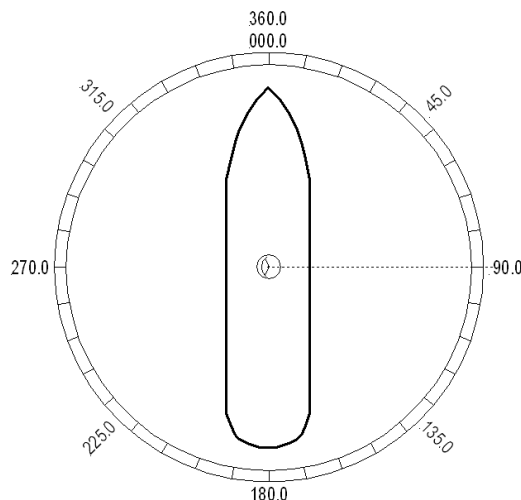

Figure 5-3 Antenna stops past the Bow

5.4.2. To Enter the HFO value:

To enter the calculated HFO value, press & hold both LEFT and RIGHT arrows for six seconds to enter the parameter menu at the EL TRIM parameter window. Press DOWN arrow key numerous times (about 21) until you have selected the REMOTE COMMAND window.

In the REMOTE COMMAND window, press the LEFT arrow key until you have underscored the left most character in the displayed value (ie the A in "A0000"). Use the UP/DOWN arrow keys to increment/decrement the underscored character until it is upper case N ("N0000" should appear in the command window). Press the RIGHT arrow key to move the cursor under the most significant digit, then use the UP arrow key to increment it to a value of 6 (the display is now "N6000"). Set the three digits to the right of the 6 to the three digit HFO value from 000 to 255 (corresponding to 0 to 360 degrees) that you calculated above. Use the LEFT/RIGHT keys to underscore the desired digit(s) then use the UP/DONW arrow keys to increment/decrement the underscored value. When you have finished editing the display value, press ENTER to send the HFO value command to the PCU (but it is not save yet).

If you want to find out what the **current** HFO value is key in N6999 and hit ENTER.

When completed, you must save the desired HFO value. Press ENTER several times to select the REMOTE PARAMETERS display. Press the LEFT or RIGHT arrow key to enter writing mode and then press the ENTER to save the HFO value in the PCUs NVRAM.

EXAMPLE: In the “Antenna stopped before the Bow” example above, the HFO calculated was 222. To enter this value:

1. Set the Remote Command value to "N6222".
2. Press **ENTER** to send this HFO to the PCU. The display should now show "N0222".
3. When completed, you must save the desired HFO value. Press **ENTER** several times to select the **REMOTE PARAMETERS** display. Press the **LEFT** or **RIGHT** arrow key to enter writing mode and then press the **ENTER** to save the HFO value in the PCUs NVRAM.

You have to drive the antenna CW in azimuth until the home switch is actuated, or re-initialize the antenna to begin using the new HFO value you have entered and saved. To re-initialize the antenna from the REMOTE COMMAND window of the ACU;

1. Press **UP** arrow key several times to return to the **REMOTE COMMAND** display.
2. Press the **LEFT** or **RIGHT** arrow key to enter edit mode. Use the **LEFT/RIGHT** and **UP/DOWN** arrow keys to set the character and digits to "0090" and then press the **ENTER** key.

This resets the PCU on the antenna. The antenna will reinitialize with this command (Performs a similar function as a power reset of the antenna) and the new home flag offset value will be used to calibrate the Relative position of the antenna.

5.5. Radiation Hazard and Blockage Mapping (AZ LIMIT parameters)

The ACU can be programmed with relative azimuth sectors (zone) where blockage exists or where transmit power would endanger personnel who are frequently in that area.

Refer to your ACU Manual for instructions on programming of these zones.

5.6. TX Polarity Setup

To prevent inadvertent switching of the transmit polarity, the user can lock out NS/EW toggle feature and force the transmit polarity to be fixed horizontal or vertical with the TX POLARITY parameter.

With the feed in the center of its polarization adjustment range, observe the transmit port polarity (vector across the short dimension of the transmit wave-guide).

If the transmit polarity in the center of the travel range is vertical, use the following entries:

- 2 Vertical Transmit Polarity
- 4 Horizontal Transmit Polarity

If the Transmit polarity in the center of the travel range is horizontal, use the following entries:

- 2 Horizontal Transmit Polarity
- 4 Vertical Transmit Polarity

5.7. TRACK DISP

This parameter set the selections that the user will see in the Tracking - Band Selection menu. Band Selection **must** be set to the appropriate selection for Tracking to operate properly.

Band selection controls the **local** logic output state of SW1 output terminal on the Terminal Mounting Strip PCB and **remote** C/Ku relays (or other switches) on the antenna pedestal.

The factory default selections and SW1 status for your 9797B is listed in the following table:

Setting	Displayed band selection	ADE Band Select Parameters (Tone, Voltage & Aux Status)	TMS SW1 Status
0000	C	Tone OFF, Volt 13, Aux 0	Open
	X	Tone OFF, Volt 18, Aux 0	Short
	KuLo	Tone OFF, Volt 13, Aux 1	Open
	KuHi	Tone OFF, Volt 18, Aux 1	Short

When the SW1 output is shorted to ground a current sink of 0.5 amps **max** is provided to control below decks band selection tone generators or coax switches. When SW1 output is open it is a floating output.

5.8. ACU Factory Default Parameter Settings – Series 97A & Series 00 Antennas

The following table shows the factory default parameters for the ACU interfaced to a Series 97A Antenna. You may need to optimize some of these parameters. Refer to the individual parameter setting information in the Setup section of your ACU manual.

PARAMETER	C-Band DishScan	Ku-Band DishScan	My Parameters
EL TRIM	0		
AZ TRIM	0		
AUTO THRES	100		
EL STEP SIZE	0	1	
AZ STEP SIZE	0	1	
STEP INTEGRAL	0		
SEARCH INC	10	5	
SEARCH LIMIT	200	100	
SEARCH DELAY	30		
SWEEP INC (DAC-03)	0040		
SYSTEM TYPE	TXRX=5 * TVRO=69		
GYRO TYPE	2		
POL TYPE	72		
POL OFFSET	30		
POL SCALE	90		
AZ LIMIT 1	0		
AZ LIMIT 2	0		
AZ LIMIT 3	0		
AZ LIMIT 4	0		
AZ LIMIT 5	0		
AZ LIMIT 6	0		
5V OFFSET	0		
5V SCALE	0		
TRACK DISP	0000		
TX POLARITY	2 or 4		

*** Modem Lock input & Modem TX Mute functions are NOT set, refer to SYSTEM TYPE parameter information.**

6. Functional Testing

If not already ON, Turn ON the Power switch on the front panel of the ACU.

6.1. ACU / Antenna System Check

1. Press RESET on the ACU front panel to initialize the system. Verify the display shows "SEA TEL INC - MASTER" and the ACU software version number. Wait 10 seconds for the display to change to "SEA TEL INC - REMOTE" and the PCU software version number.
2. If the display shows "REMOTE INITIALIZING" wait for approximately 2 minutes for the antenna to complete initialization and report the Antenna Model and PCU software version. If "REMOTE NOT RESPONDING" is displayed, refer to the Troubleshooting Section of this manual.
3. Press the **NEXT** key repeatedly to display the *Ship*, *Satellite*, *Antenna* and *Status* menu displays. This verifies that the displays change in the correct response to the keys.

6.2. Latitude/Longitude Auto-Update check

This verifies that the GPS position information is automatically updating..

1. Press the **NEXT** key repeatedly to display the *Ship* menu. Press **ENTER** to access edit mode and view the current Latitude value.
2. Press the LEFT arrow key to bring the cursor up under the ones digit, press UP and then hit ENTER. The display should immediately show a latitude value one degree higher, but then will be overwritten within several seconds (back to the previous value) by the GPS engine.

This test does not need to be repeated in the Longitude menu.

6.3. Ship Heading – Gyro Compass Following Check

This verifies that the Heading display is actually following the Ships Gyro Compass.

1. Press the **NEXT** key repeatedly to display the *Ship* menu. If the boat is underway, monitor the Heading value to verify that the display changes in the correct response to the Gyro Compass input (Heading value should always be exactly the same as the Gyro Compass repeater value).
2. If the ship is NOT underway, most ships will turn +/- 1-2 degrees at the pier, monitor the Heading value to verify that the display changes in the correct response to the Gyro Compass input (Heading value should always be exactly the same as the Gyro Compass repeater value).

6.4. Azimuth & Elevation Drive

This verifies that the antenna moves in the correct response to the keys.

1. Press the NEXT key several times to display the Antenna menu.
2. Press the Tracking key to toggle Tracking OFF. Press the UP arrow key repeatedly and verify that the antenna moves up in elevation.
3. Press the DOWN arrow key repeatedly and verify that the antenna moves down in elevation.
4. Press the RIGHT arrow key repeatedly and verify that the antenna moves up (CW) in azimuth.
5. Press the LEFT arrow key repeatedly and verify that the antenna moves down (CCW) in azimuth.

6.5. Four Quadrant Tracking Test

This verifies that the antenna moves in the correct response to the keys, that Tracking is signaling correctly and that the Tracking commands are being carried out (antenna drives to peak).

1. Verify antenna is locked onto and tracking a satellite
2. Press the **NEXT** key several times to display the *Antenna* menu.
3. Note the current peak AGC value. Press the **Tracking** key to toggle Tracking OFF, press the **UP** arrow key repeatedly to move the antenna up in elevation until AGC falls about 100 counts. Turn Tracking ON and verify that the antenna moves back down in elevation and that the AGC rises to its' previous high value.

4. Note the current peak AGC value. Press the **Tracking** key to toggle Tracking OFF, press the **DOWN** arrow key repeatedly to move the antenna down in elevation until AGC falls about 100 counts. Turn Tracking ON and verify that the antenna moves back up in elevation and that the AGC rises to its' previous high value.
5. Note the current peak AGC value. Press the **Tracking** key to toggle Tracking OFF, press the **RIGHT** arrow key repeatedly to move the antenna up in azimuth until AGC falls about 100 counts. Turn Tracking ON and verify that the antenna moves back down in azimuth and that the AGC rises to its' previous high value.
6. Note the current peak AGC value. Press the **Tracking** key to toggle Tracking OFF, press the **LEFT** arrow key repeatedly to move the antenna down in azimuth until AGC falls about 100 counts. Turn Tracking ON and verify that the antenna moves back up in azimuth and that the AGC rises to its' previous high value.

6.6. Blockage Simulation Test

Blockage output function is used to modify the behavior of Tracking and Searching when there is a known blockage zone. The ACU provides a contact closure to ground on the SW2 terminal of the Terminal Mounting Strip when the antenna is pointed within any one of the blockage/hazard zones or the system is searching, targeting, unwrapping or is mis-pointed by 0.5 degrees or more (FCC TX Mute function for Transmit/Receive systems **only**). The contact closure is a transistor switch with a current sinking capability of 0.5 Amp. This logic output control signal is used for:

- When used as simple "BLOCKED" logic output for a single Sea Tel antenna, this output could be used to light a remote LED and/or sound a buzzer to alert someone that the antenna is blocked, and signal is lost.
- In a "Dual Antenna" installation, this logic output(s) is used to control Dual Antenna Arbitrator panel of coax switches to switch the source inputs to the matrix switch from Antenna "A" to Antenna "B", and vice versa.
- When used as simple "RF Radiation Hazard" logic output for a single Sea Tel TX/RX antenna, this output could be used to suppress RF transmissions while the antenna is pointed where people would be harmed by the transmitted microwave RF power output. The SW2 output would be interfaced to the satellite modem to **disable** the TX output signal from the Satellite TXRX Modem whenever the antenna is within the RF Radiation Hazard zone(s).
- When used for "FCC TX Mute" logic output for a single Sea Tel TX/RX antenna, this output could be used to suppress RF transmissions whenever the antenna is mis-pointed 0.5 degrees or more, is blocked, searching, targeting or unwrapping. The SW2 output would be interfaced to the satellite modem to **disable/mute** the TX output signal from the Satellite TX/RX Modem. When the mute condition is due to antenna mis-pointing, it will not **un-mute** until the pointing error of the antenna is within 0.2 degrees. The default output is contact closure to ground when the antenna is mis-pointed, therefore provides a **ground** to "Mute" the satellite modem on the SW2 terminal of the Terminal Mounting Strip. If your satellite modem requires an **open** to "Mute", refer to SYSTEM TYPE parameter 16 value to reverse the output logic from the ACU.



To Test the blockage function:

7. Press the NEXT key until you are at the Status menu. Press ENTER to access the Tracking menu.
8. Press the RIGHT arrow key to bring up and move the cursor to the far right. Press the UP arrow to simulate a manual BLOCKED condition. BLOCKED will appear in the Tracking display.
9. Verify that SW2 terminal shorts to ground (or open circuit if you have SYSTEM TYPE configured to reverse the output logic) and that the external alarms actuate OR the Dual Antenna Arbitrator coax switches toggle (if antenna B is not blocked) OR the Satellite Modem TX is disabled/muted.
10. Press the LEFT arrow key and then press the UP arrow key to turn the simulated blocked condition OFF. BLOCKED will disappear from the Tracking display.
11. Verify that SW2 terminal is open circuit (or ground if you have logic reversed) and that the external alarms deactivate OR the Satellite Modem TX is un-muted. The Dual Antenna Arbitrator coax switches should not toggle until you manually block Antenna B ACU.

This Page Intentionally Left Blank

7. Maintenance and Troubleshooting

This section describes the theory of operation to aid in troubleshooting and adjustments of the antenna system. Also refer to the Troubleshooting section of your ACU manual for additional troubleshooting details.

	WARNING: Electrical Hazard – Dangerous AC Voltages exist inside the Antenna Pedestal Breaker Box. Observe proper safety precautions when working inside the Pedestal Breaker Box.
	WARNING: Electrical Hazard – Dangerous AC Voltages exists on the side of the Antenna Pedestal Power Supply. Observe proper safety precautions when working inside the Pedestal Power Supply.

7.1. Warranty Information

Sea Tel Inc. supports its Series 00 systems with a **ONE YEAR** warranty on parts and labor.

What's Covered by the Limited Warranty?

The Sea Tel Series 00 Limited Warranty is applicable for parts and labor coverage to the complete antenna system, including all above-decks equipment (radome, pedestal, antenna, motors, electronics, wiring, etc.) and the Antenna Control Unit (ACU).

What's **NOT** Covered by the Limited Warranty?

It does **not** include Television sets, DBS/DTH receivers, multi-switches or other distribution equipment, whether or not supplied by Sea Tel commonly used in TVRO Systems. Televisions, DBS/DTH receivers and accessories are covered by the applicable warranties of the respective manufacturers.

It does **not** include Transmit & Receive RF Equipment, Modems, Multiplexers or other distribution equipment, whether or not supplied by Sea Tel commonly used in Satellite Communications (TXRX) Systems. These equipments are covered by the applicable warranties of the respective manufacturers.

Factory refurbished components used to replace systems parts under this warranty are covered by this same warranty as the original equipment for the balance of the original warranty term, or ninety (90) days from the date of replacement, whichever occurs last. Original Installation of the Series 00 system must be accomplished by or under the supervision of an authorized Sea Tel dealer for the Sea Tel Limited Warranty to be valid and in force.

Should technical assistance be required to repair your system, the first contact should be to the agent/dealer you purchased the equipment from.

Please refer to the complete warranty information included with your system.

7.2. Recommended Preventive Maintenance

Ensure that all of the normal operating settings (LAT, LON, HDG, SAT and all of the Tracking Receiver settings) are set correctly. Refer to the Functional Testing section to test the system.

7.2.1. Check ACU Parameters

Assure that the parameters are set correctly (you may wish to record them in the Factory Default Settings, in section 5 of this manual).

7.2.2. Latitude/Longitude Auto-Update check

Refer to the Latitude & Longitude Update check procedure in the Functional Testing section of this manual.

7.2.3. Heading Following

Refer to the Heading Following verification procedure in the Functional Testing section of this manual.

7.2.4. Azimuth & Elevation Drive

Refer to the Azimuth & Elevation Drive check procedure in the Functional Testing section of this manual.

7.2.5. Test Tracking

Refer to the four quadrant Tracking check procedure in the Functional Testing section of this manual.

7.2.6. Visual Inspection - Radome & Pedestal

Conduct a good, thorough, visual inspection of the radome and antenna pedestal. Visually inspect the inside surface of the radome top and of the antenna pedestal. Look for water or condensation, rust or corrosion, white fiberglass powder residue, loose wiring connections, loose hardware, loose or broken belts or any other signs of wear or damage.

1. Radome Inspection - All the radome flanges are properly sealed to prevent wind, saltwater spray and rain from being able to enter the radome. Re-seal any open ("leaky") areas with marine approved silicone sealant. If heavy condensation, or standing water, is found inside the radome, isolate and seal the leak, and then dry out the radome. Small (1/8 inch) holes may be drilled in the base pan of the radome to allow standing water to "weep" out.
2. Antenna Pedestal Inspection - The shock/vibration springs and/or wire rope Isolators should not be frayed, completely compressed, or otherwise damaged. The plated and painted parts should not be rusted or corroded. The harnesses should not be frayed and all the connectors should be properly fastened and tightened. All hardware should be tight (no loose assemblies or counter-weights). Replace, re-coat, repair and/or tighten as necessary.

7.2.7. Mechanical Checks

Turn the pedestal power supply OFF

1. Inspect inside of radome for signs that the dish or feed have been rubbing against the inside of the fiberglass radome.
2. Rotate the pedestal through its full range of azimuth motion. The antenna should rotate freely and easily with light finger pressure.
3. Rotate the pedestal through full range of elevation rotation. The antenna should rotate freely and easily with light finger pressure.
4. Rotate the pedestal through full range of cross-level rotation. The antenna should rotate freely and easily with light finger pressure.
5. Rotate the level cage through the full 90 degrees of rotation from CCW stop to CW stop. The level cage antenna should rotate freely and easily with light finger pressure. Attached cables should not cause the cage to spring back more than a few degrees from either stop when released.
6. Inspect all drive belts for wear (black dust on/under the area of the belt).
7. Inspect AZ Drive chain. IF chain is beginning to show signs of rust or corrosion, apply a **light** coat of light duty oil to the chain. Wipe excess oil off to leave a light coating on the chain. **DO NOT over-lubricate.**

7.2.8. Check Balance

Check the balance of the antenna, re-balance as needed (refer to the Balancing the Antenna procedure below).

7.2.9. Observe Antenna Initialization

Observe the Antenna Initialization as described in the Troubleshooting section below.

7.3. Troubleshooting

7.3.1. Theory Of Stabilization Operation

The antenna system is mounted on a three axis stabilization assembly that provides free motion with 3 degrees of freedom. This assembly allows the inertia of the antenna system to hold the antenna pointed motionless in inertial space while the ship rolls, pitches and yaws beneath the assembly. Three low friction torque motors attached to each of the three free axes of the assembly provide the required force to overcome the disturbing torque imposed on the antenna system by cable restraints, bearing friction and

small air currents within the radome. These motors are also used to re-position the antenna in azimuth and elevation.

The Pedestal Control Unit (PCU) uses inputs from the level cage sensors to calculate the amount of torque required in each axis to keep the antenna pointed within +/-0.2 degrees. The primary sensor input for each loop is the rate sensor mounted in the Level Cage Assembly. This sensor reports all motion of the antenna to the PCU. The PCU immediately responds by applying a torque in the opposite direction to the disturbance to bring the antenna back to its desired position. Both the instantaneous output of the rate sensor (Velocity Error) and the integrated output of the rate sensor (Position Error) are used to achieve the high pointing accuracy specification.

The calculated torque commands are converted to a 5 volt differential analog signal by a Digital to Analog converter (D/A) and sent to each of three Brush-Less Servo Amplifiers. These amplifiers provide the proper drive polarities and commutation required to operate the Brush-Less DC Servo Motors in torque mode. The Torque acting on the mass of the antenna cause it to move, restoring the rate sensors to their original position, and closing the control loop.

Since the rate sensors only monitor motion and not absolute position, a second input is required in each axis as a long term reference to keep the antenna from slowly drifting in position. The Level and Cross Level reference is provided by a two axis tilt sensor in the level cage assembly. The Azimuth reference is provided by combining the ships gyro compass input and the antenna relative position.

7.3.2. **Series 97B-20 Quad Ku-Band TVRO RF Flow**

Refer to the System Block Diagram in the Drawings section of this manual. The feed has a 24VDC motor to rotate the body of the OMT to optimize the linear polarization angle of the LNBS to the polarization angle of the signal coming from the targeted satellite. The 24VDC motor is remotely controlled by the ACU (Manual OR Auto-Polarization) through the PCU and Shielded Polang Relay Assy.

One Quad Ku-Band LNB is installed. All four Ku-Band polarizations (High and Low Band H&V) are routed through the four channels of the rotary joint.

7.3.2.1. **Channel 1 (White)**

HORIZ Ku low-band coax has +18 VDC Voltage supplied by Matrix Switch plus Ku-Band IF (950-1950MHz) output from the Ku low-band horizontal LNB output. The Ku low-band IF output passes through this channel of the 75 ohm coaxial rotary joint, to the base of the radome, down the ADE-BDE coax to the Ku low-band HORIZ input of the four port Matrix Switch. The ACUs' Tracking Receiver and each of the Ku-Band Satellite Receivers is connected by coax cable to one of the available IF outputs of the Matrix Switch. Total signal loss of this path is the accumulation of the coax cable losses from antenna to receiver, plus the loss in the Matrix Switch.

7.3.2.2. **Channel 2 (Blue)**

VERT Ku low-band coax has +13 VDC Voltage supplied by Matrix Switch plus Ku-Band IF (950-1950MHz) output from the Ku low-band vertical LNB output **AND** Antenna Control RF (Pedestal TX at 1.1 & Base TX at 1.5 MHz) which is added onto this coax by the Pedestal FSK Modem (connected to the PCU). The Ku low-band IF output passes through this channel of the 75 ohm coaxial rotary joint, to the base of the radome, down the ADE-BDE coax to the Base FSK Modem (connected to the ACU) and then to the Ku low-band VERT input of the four port Matrix Switch. Total signal loss of this path is the accumulation of the coax cable losses from antenna to receiver, plus the loss in the Pedestal & Base Modems (1 dB **max** loss each) and the Matrix Switch.

7.3.2.3. **Channel 3 (Red)**

HORIZ Ku high-band coax has +18 VDC Voltage supplied by Matrix Switch plus Ku-Band IF (1100-2150MHz) output from the Ku high-band horizontal LNB output. The Ku high-band IF output passes through this channel of the 75 ohm coaxial rotary joint, to the base of the radome, down the ADE-BDE coax to the Ku high-band HORIZ input of the four port Matrix Switch. The ACUs' Tracking Receiver and each of the Ku-Band Satellite Receivers is connected by coax cable to one of the available IF outputs of the Matrix Switch. Total signal loss of this path is the accumulation of the coax cable losses from antenna to receiver, plus the loss in the Matrix Switch.

7.3.2.4. **Channel 4 (Green)**

VERT Ku high-band coax has +13 VDC Voltage supplied by Matrix Switch plus Ku-Band IF (1100-2150MHz) output from the Ku high-band vertical LNB output. The Ku high-band IF output passes through this channel of the 75 ohm coaxial rotary joint, to the base of the radome, down the ADE-BDE coax to the Ku high-band VERT input of the four port Matrix Switch. The ACUs' Tracking

Receiver and each of the Ku-Band Satellite Receivers is connected by coax cable to one of the available IF outputs of the Matrix Switch. Total signal loss of this path is the accumulation of the coax cable losses from antenna to receiver, plus the loss in the Matrix Switch.

7.3.3. Antenna Initialization (Series 97B & Series 00)

Turn the pedestal power supply ON. The PCU will initialize the stabilized portion of the mass to be level with the horizon and at a prescribed Azimuth and Elevation angles. The antenna will go through the specific sequence of steps (listed below) to initialize the level cage, elevation, cross-level and azimuth to predetermined starting positions.

Initialization is completed in the following phases, each phase must complete properly for the antenna to operate properly (post-initialization). Observe the Initialization of the antenna pedestal.

- Step 1. The brakes on the Elevation and Cross-Level motors release.
- Step 2. The level platform motor drives the Level Cage CW, issuing extra steps to assure that the cage is all the way to the mechanical stop. Then the Level Cage will be driven exactly 45.0 degrees CCW.
- Step 3. Elevation axis then activates - Input from the LV axis of the tilt sensor is used to drive the Elevation of the equipment frame to bring the tilt sensor LV axis to level. This step takes approximately 10 seconds and will result in the dish being at 45.0 degrees in elevation. The level cage may still be tilted left or right at this time.
- Step 4. Cross-Level axis activates - Input from the CL axis of the tilt sensor is used to drive Cross-Level of the equipment frame to bring the cross-level axis of the tilt sensor to level (this results in the tilt of the Cross-Level Beam being level). This step takes approximately 10 seconds.
- Step 5. Azimuth axis activates - Antenna drives CW in azimuth until the "Home Flag" signal is produced. This signal is produced by a Home Switch hitting a cam (or by a Hall Effect sensor in close proximity to a Magnet). After another 10 second wait, the antenna will report its version number at the Antenna Control Unit (ACU).

This completes the phases of initialization. At this time the antenna elevation should 45.0 degrees and Relative azimuth should be at home flag (home switch engaged on the home flag cam).

If any of these steps fail, or the ACU reports model "xx97", re-configure the PCU as described in the this chapter. If initialization still fails, this indicates a drive or sensor problem, refer to the Troubleshooting section.

7.3.4. Troubleshooting using DacRemP

While troubleshooting a Sea Tel 3-Axis Antenna System, you must classify the fault you are dealing with as a failure within one of 3 major system functions, Targeting, Stabilization, and Tracking. Should there be a failure with any one of these functions, your system will not operate properly. A few simple checks may help determine which fault (if any) that you are dealing with. The matrix below lists some test(s) and which of the DacRemP graph selection would be best to use to identify a fault. The end of this chapter contains examples on how to use DacRemP to diagnose a fault.

Targeting: is the ability to accurately point the antenna to an angular position in free space and is controlled by the ACU. (Does the system drive to the Azimuth, Elevation, and Polarity positions within 1 degree of the desired satellite?)

Stabilization: is the process of de-coupling the ships motion from the antenna and is controlled by the PCU. (Does the system maintain the satellite link after turning off TRACKING?)

Tracking: is the process of issuing fine adjustments to the **pointing** angle of the antenna to optimize the received signal level and is controlled by the ACU. (Does the system pass a four quadrant-tracking test?)

Functional Test(s)	DacRemP Graph Selection to use	System Function(s)
Four Quadrant Tracking.	ADMC (Position)	Tracking
Azimuth Encoder Verification.	ADMC (Position)	Targeting
Sea Trial	ADMC (Position)	Targeting Tracking Stabilization

Side Lobe Plots	ADMC (Position)	Tracking
Targeting Alignment (AZ & EL Trims)	ADMC (Position)	Targeting
Determine Blockage Mapping	ADMC (Position)	Tracking
Unwrap recovery (Limited Az systems only)	ADMC (Position)	Stabilization
Pedestal Gain Verification	DISPIVC (Loop Error)	Stabilization
Home switch (flag) verification (Unlimited Az systems only)	DISPV (Ref)	Stabilization
Remote Tilt Verification	DISPV (Ref)	Targeting Stabilization
Level cage alignment Verification (sensor alignment)	DISPV (Ref)	Targeting Stabilization
Rate Sensor Output Verification	DISPW (Rate)	Stabilization
Level and CL fine balance Verification	DISPTC (Drive)	Stabilization
AZ Friction Torque Test	DISPTC (Drive)	Stabilization
DishScan Drive/Phase	DishScan XY	Tracking Stabilization

7.3.5. Antenna Loop Error Monitoring

The DacRemP **DISPIVC** graph chart provides a means for monitoring the accumulated velocity errors of the antenna for diagnostic purposes. If this error is excessive, it indicates external forces are acting on the antenna. These forces may be the result of but not restricted to static imbalance, excessive bearing friction, cable binding, or wind loading. If these forces cause the antenna to mis-point by more than 0.5° from the desired position the PCU will flag a “Stab Limit” error.

- To view the position error, select the **DisplVC (LoopError)** graph chart.
- This chart displays sensed axis errors via three traces, CL (Cross Level), LV (Elevation), and AZ (Azimuth), at a fixed 0.05°/ vertical division.
- The normal trace average will plots its display ± 3 divisions from the red reference line. Any trace line average plotted above this is of concern and troubleshooting required. The example below shows the forces exerted onto the antenna as a resultant of DishScan Drive.



- The example below shows the results of various forces put upon antenna.

- Cross-Level Axis physically moved CCW (down to the left.) and then CW (up to the right.)

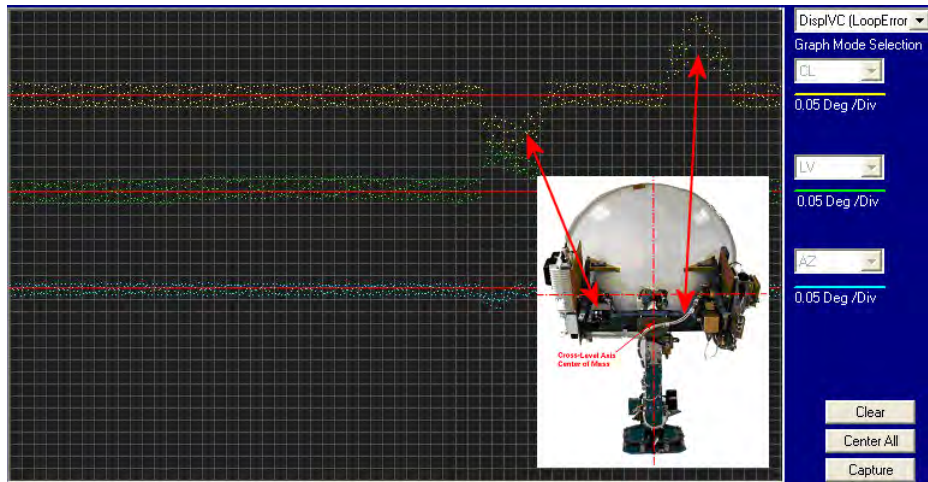

- Elevation Axis physically moved CW. (reflector slightly pushed up) and then physically moved CCW. (reflector slightly pushed down.) At the end of chart recording shows DishScan Drive turned Off, notice the lack of accumulated IVC errors.

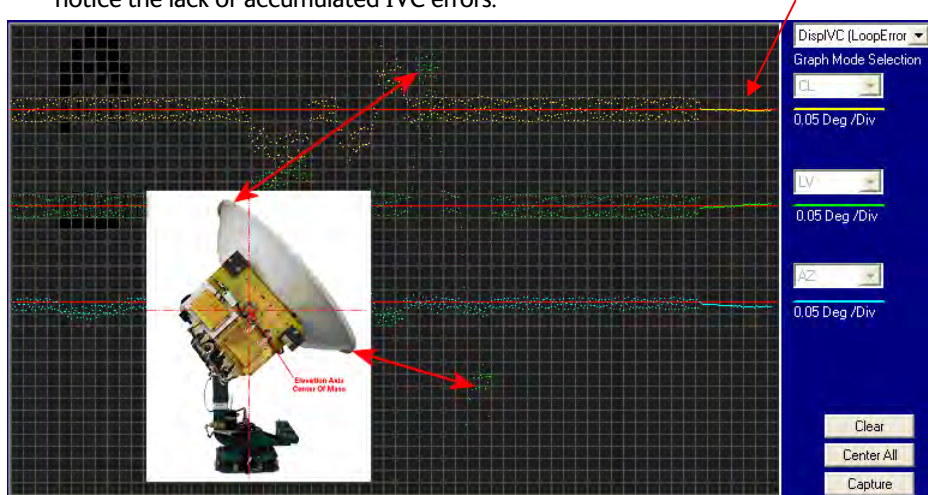

7.3.6. Reference Sensor Monitoring

The DacRemP **DISPV** graph chart provides a means for monitoring the output of the 2 Axis Tilt Sensor and the Home Switch sensor for diagnostic purposes. The Tilt sensor (located inside the Level Cage Assembly) is the primary input for the antenna's reference to the horizon (0° Elevation and 90° Cross-Level). While the Home Switch Sensor (located at the antenna base) is used to calibrate the antenna's position relative to the vessels BOW.

- To view the reference sensors, select the **Disp V (Ref)** graph chart.
- This chart displays the output of the Tilt Sensor via two traces, CL (Cross Level), LV (Elevation) at a fixed 1°/ vertical division, and the home flag logic level via a single trace, AZ (Azimuth).
- The normal trace display for the Tilt Sensor, after performing remote tilt calibration, will be ± 4 divisions from the red reference line. Any trace line average plotted above this is of concern and troubleshooting required. See below for a screen capture of an antenna that is Level in both the Cross-Level and Elevation Axis.



- The Cross Level Tilt display should plot on the red reference line when the level cage is level, referenced to the horizon. It should decrease (plots below red line) when the antenna is tilted to the left and increase (plots above red line) when tilted to the right. See below for a screen capture of an abnormal CL trace Plot, it is an indication that the antenna that is either listed to the right approx. 4 degrees or the PCU requires to much CL tilt bias.



- The Level tilt display should plot on the red reference line when the level cage is level, referenced to the horizon. It should decrease (plots below red line) when the antenna is tilted forward (EL down) and increase (plots above red line) when tilted back (EL up).
- The Azimuth display for the Home Switch will normally display a logic level high (plots directly on Red reference line after clicking on the **Center All** button) when the home flag is NOT engaged and changing to a logic level low when engaged. See below for a screen capture of an antenna that was driven so that the Home Flag switch is engaged.

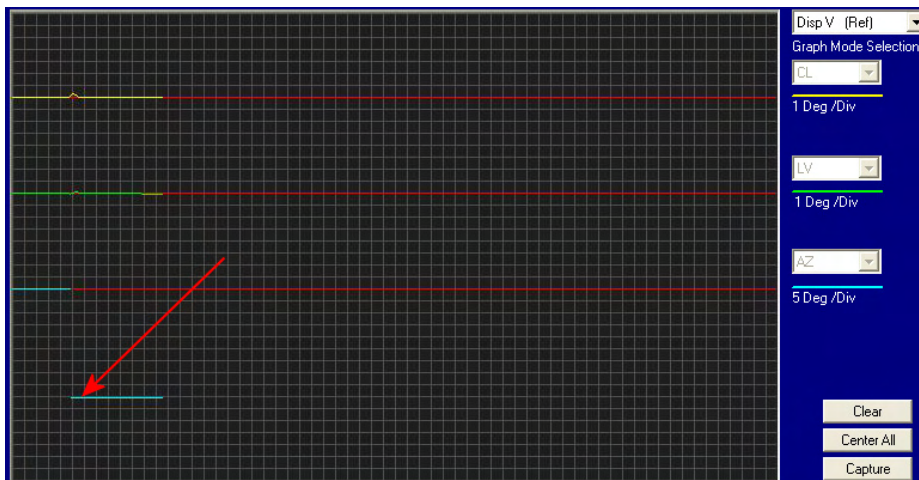

7.3.7. Open Loop Rate Sensor Monitoring

The DacRemP **DISPW** graph chart provides a means for monitoring the output of the 3 solid state rate sensors (located inside the Level Cage Assembly) for diagnostic purposes. The rate sensors are the primary inputs to the PCU for stabilization.

- To monitor the rate sensors, select the **Disp W (Rate)** graph chart
- This chart displays sensed output from the 3 rate sensors via three traces, CL (Cross Level), LV (Elevation), and AZ (Azimuth), at a fixed 1°/Second/vertical division.
- A normal trace display will be ± 1 divisions from the red reference line. The example shown below shows an antenna that is NOT currently sensing motion in any axis.



- The Cross Level display should decrease (plots below red line) as the antenna is tilted to the left and increase (plots above red line) as the antenna tilted to the right.
- The Level display should decrease (plots below red line) as the antenna is tilted forward and increase (plots above red line) as the antenna is tilted back.
- The Azimuth display should decrease (plots below red line) as the antenna is rotated CCW and increase (plots above red line) as the antenna is rotated CW. In the example below, the output of the Azimuth rate sensor is plotted above the reference line, indicating that the antenna was driven CW in Azimuth. Due to the in-practicality of driving an axis at a consistent rate, verification of rate sensor output is, for the most part restricted to a positive or negative response of the Level Cage movement (plotting above or below the red reference line of each axis).



7.3.8. Open Loop Motor Test

The DacRemP **Comm Diagnostics** Window provides a means to enter in Remote Commands for driving each individual torque motor to test that motors functionality. By driving each axis and observing the resulting motion of the antenna, a coarse operational status of the motor and motor driver may be established.

- To manually drive the motors, select the “**Comm Diagnostics**” window under to the Tools submenu or Press “CTRL + C”
- Using the small field in the upper left hand corner of the window, type in the remote command and verify the motor appropriately drives in the direction commanded.
- To drive the Cross Level motor, key in ^1064, ^1128 or ^1192 and press **ENTER** to drive the Cross Level axis LEFT, OFF or RIGHT respectively.
- To drive the Level motor, key in ^2064, ^2128 or ^2192 and press **ENTER** to drive the level axis FORWARD, OFF or BACKWARD respectively.
- To drive the Azimuth motor, key in ^3064, ^3128 or ^3192 and press **ENTER** to drive the azimuth axis CW, OFF or CCW.

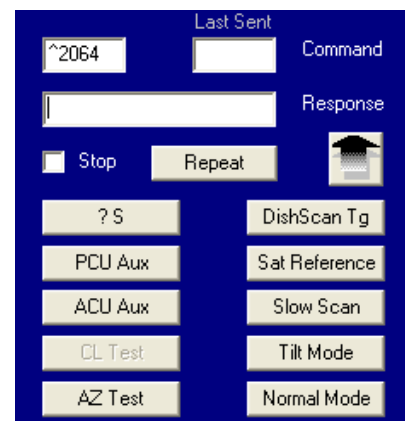

7.3.9. To Disable/Enable DishScan

To be able to use Step Track, or to revert to Conscan, as your active tracking mode you will have to disable DishScan.

Select the **DISHSCAN** parameter window on the ACU:

1. Press the RIGHT arrow, then press the UP arrow and last press the ENTER key to turn DishScan mode ON.
2. Press the RIGHT arrow, then press the DOWN arrow and last press the ENTER key to turn DishScan Mode OFF.

If you change this remote parameter, you must save the change using REMOTE PARAMETERS.

If DishScan is **OFF** and the **Step Integral** parameter is set to **0000**, you will get a **constant ERROR 0016** (DishScan error) and you will see **zeros** flashing in the lower left of the Azimuth and Elevation ENTRY menu displays. This is a visual indication that DishScan is turned OFF.

7.3.10. Satellite Reference Mode

The ships gyro compass input to the ACU may be accurate and stable in static conditions and yet may NOT be accurate or stable enough in some underway dynamic conditions. If there is no gyro compass or if the

input is corrupt, not stable or not consistently accurate the tracking errors will become large enough to cause the antenna to be mis-pointed off satellite.

Satellite Reference Mode will uncouple the gyro reference from the azimuth rate sensor control loop. This decoupling of the Gyro source only happens 5 minutes after an azimuth command has been sent to the antenna by means of an AZ target command, a search pattern initiated, or the a Satellites longitudinal position is targeted. When operating in Satellite Reference Mode changes in ships gyro reading will reflect its changes to the ACU's display but will not directly affect the azimuth control loop. The Pedestal Control Unit will stabilize the antenna based entirely on the azimuth rate sensor loop and the tracking information from DishScan. This will keep the azimuth rate sensor position from eventually drifting away at a rate faster than the tracking loop can correct by using the tracking errors to regulate the rate sensor bias.

Satellite Reference Mode can be used as a diagnostic mode to determine if tracking errors are caused by faulty gyro inputs.

Satellite Reference Mode **MUST be used when:**

- No Gyro Compass is available
- Frequent or constant ACU Error Code 0001 (Gyro Compass has failed)
- Gyro Compass output is NMEA heading
- Flux Gate Compass is being used
- GPS Satellite Compass is being used

To view, or change, the Satellite Reference Mode status, select the SAT REF remote parameter:



1. Press the RIGHT arrow, then press the UP arrow and last press the ENTER key to turn Satellite Reference Mode ON.
2. Press the RIGHT arrow, then press the DOWN arrow and last press the ENTER key to turn Satellite Reference Mode OFF.

If you change this remote parameter, you must save the change using REMOTE PARAMETERS.

7.3.11. To Read/Decode an ACU Error Code 0008 (Pedestal Function Error):

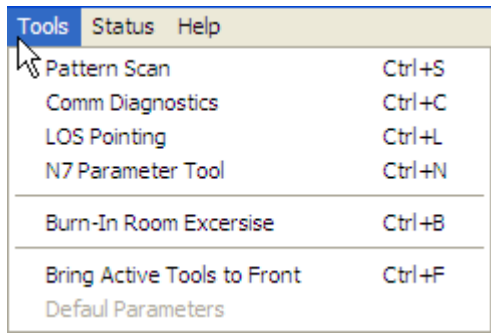
An Error Code 8 as reported by the ACU is an indication that the above decks equipment has experienced an error. One of the functions available within the “Comm Diagnostics” tool window provides the means to read and decode the actual discreet Pedestal Function Error.

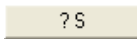
<ol style="list-style-type: none"> 1. Select the “Comm Diagnostics” window under to the Tools submenu or Press “CTRL + C” 	
--	--

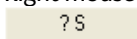
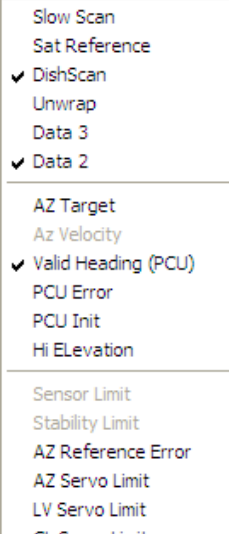
<p>2. Left mouse click on the  icon.</p>	
<p>3. Right mouse click on the  icon.</p> <p>This will display a list box with the status of the above decks pedestal filtered into 3 sections. Items preceded with a check marks indicate a flagged status. See matrix below for further information on each state.</p>	



State	Description
PCU Status (Word 1)	
Slow Scan	Indicates antenna is in a specialized mode, Slow Scan, which is required when ever a test requires driving the antenna >5°/sec
Sat Reference	Indicates that satellite reference mode is enabled.
DishScan	Indicates that DishScan Drive is enabled.
Unwrap	Indicates that the antenna is currently in an “Unwrap” state. This is not a valid error for unlimited azimuth antenna systems
Data 3	Indicates active communication between above decks and below decks equipment
Data 2	Indicates active communication between above decks and below decks equipment

PCU Status (Word 2)	
Az Target	Indicates the antenna is currently targeting a pre-determined azimuth position
Az Velocity	**Not a valid state**
Valid Heading (PCU)	Indicates that the PCU has received and integrated the heading value from the ACU into the Azimuth Stabilization Loop. This is NOT an indication of a proper Heading integration into ACU.
PCU Error	Indicates that one or more errors have been reported by the above decks equipment.
PCU Init	Indicates that the above decks equipment is currently performing an Initialization sequence
Hi Elevation	Indicates that the above decks equipment is operating an Elevation Position higher than 83°
PCU Error Status (Word 3)	
Sensor Limit	**Not a valid state**
Stability Limit	Indicates that the above decks equipment is mis-pointed from its intended target by more than 0.5°. (FCC Tx Mute requirements)
AZ Reference Error	Indicates a failure to integrate one the reference inputs within the Azimuth Stabilization Loop.
AZ Servo Limit	Indicates the current draw through the Azimuth Servo Amplifier (motor driver PCB) has exceeded what is required during normal operation
LV Servo Limit	Indicates the current draw through the Elevation Servo Amplifier (motor driver PCB) has exceeded what is required during normal operation
CL Servo Limit	Indicates the current draw through the Cross-Level Servo Amplifier (motor driver PCB) has exceeded what is required during normal operation

7.3.12. Remote GPS LAT/LON Position:

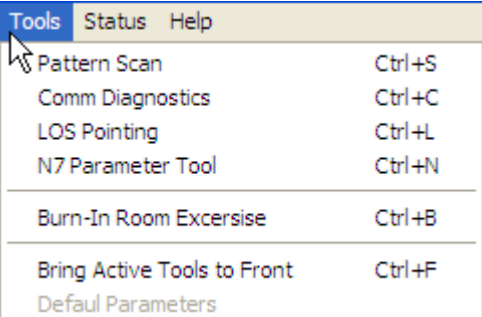
The above decks equipment has an integrated on board Furuno GPS antenna system. The Latitude and Longitude position information provided are utilized to calculate the Azimuth, Elevation, Cross-level and Polarity pointing angles of the desired satellite. The DacRemP “**Comm Diagnostics**” Window provides a means to query the GPS antenna to verify proper operation. The procedure below describes this process.

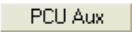
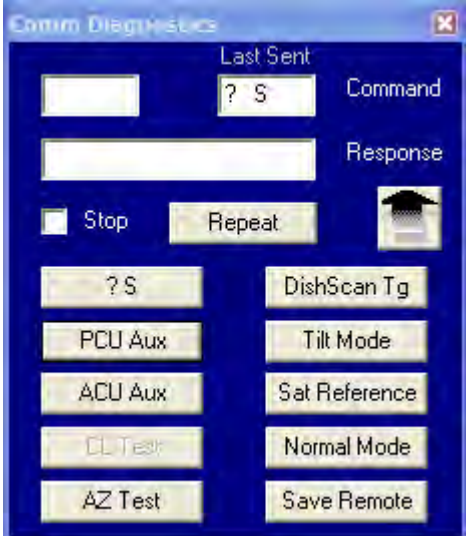
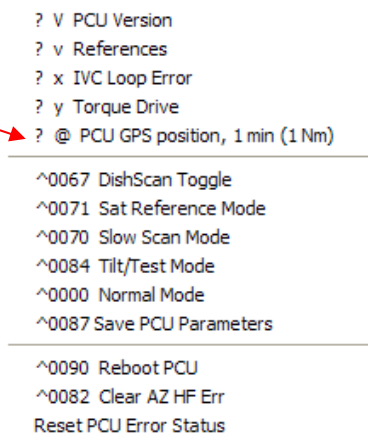
<p>1. Select the “Comm Diagnostics” window under to the Tools submenu or Press “CTRL + C”</p>	
--	--

<p>2. Left mouse click on the  icon.</p>	
<p>3. Left Mouse click on the “?@ PCU GPS position, 1 min (1 Nm)”</p>	
<p>4. In the “Response” window verify proper GPS position to within 1 nautical mile of your current position.</p> <p>The Latitude & Longitude position of the GPS will be displayed in the following format: “@ LAT,N,LON,E,A”</p> <p>Where LAT and LON are in degrees and minutes, LAT will be followed by N or S (North or South), LON will be followed by E or W (East or West), then a status character and finally a checksum character.</p>	

<p>Furuno default value is in Japan at 34.4N 135.2E (@3444,N,13521,E,,_).</p> <p>After acquiring a good fix at Sea Tel the string is @3800,N,12202,W,A` for our 38N 122W Latitude and Longitude position.</p> <p>The status character tells you the status of the GPS.</p> <p>“,” (Comma) = GPS has NOT acquired a proper fix,</p> <p>“N” = GPS fix is NOT valid</p> <p>“A” = GPS has acquired a valid fix.</p>	
---	--

7.4. Maintenance

7.4.1. Balancing the Antenna

The antenna and equipment frame are balanced at the factory however, after disassembly for shipping or maintenance, balance adjustment may be necessary. The elevation and cross-level motors have a brake mechanism built into them, therefore, **power** must be ON to release the brakes and **antenna drive** must be OFF to balance the antenna. . **Do NOT remove any of the drive belts**. Balancing is accomplished by adding or removing balance trim weights at strategic locations to keep the antenna from falling forward/backward or side to side. The antenna system is not pendulous so 'balanced' is defined as the antenna remaining at rest when left in any position. The antenna should be balanced within one ounce at the typical trim weight location of 10 inches from the axis of rotation.







1. Turn Antenna power breaker ON
2. To turn OFF antenna drive (AZ, EL & CL) follow the Pedestal Control Unit Configuration procedure in this chapter to set the PCU configuration to (N0000) but do NOT save.
3. Balance the antenna elevation axis with the elevation near horizon (referred to as front to back balance) **by adding, or subtracting, small counter-weights**.
4. Then balance Cross Level axis (referred to as left-right balance) **by moving existing counter-weights**. Do NOT add counter-weight during this step.
5. Last, balance the Elevation Axis with the antenna pointed at zenith (referred to as top to bottom balance) **by moving existing counter-weights**. Do NOT add counter-weight during this step.
6. When completed, the antenna will stay at any position it is pointed in for at least 5 minutes (with little, to no, ship motion).
7. Turn antenna power OFF, and then back ON, to re-Initialize the antenna. This will also turn antenna drive (AZ, EL & CL) back ON.

7.4.2. To Adjust Tilt:

A REMOTE TILT calibration is required to align the level cage assembly correctly so that all sensors will be aligned accurately to the axis they relate to. The fluid filled tilt sensor provides a two dimensional horizon reference. The system is not able to automatically calculate the exact center value, therefore it is necessary to perform this procedure to manually enter any offset required to make sure the PCU receives a true reference to the horizon. The procedures below describes the process of performing this calibration from either the ACU front panel or DacRemP diagnostic software by connecting the ACU's RS-422 M&C Port to an available serial port on a Laptop/Desktop computer using a standard 9 pin serial cable.

Step 1 Turn Off DishScan Drive.

Using the DAC2202 ACU Front Panel:

1. Go to Remote Command window by pressing and holding the two **LEFT & RIGHT** arrows  until the EL TRIM parameter is displayed.
2. Press and release both **Left & Right** arrow keys again. The “SAVE NEW PARAMETERS” window should now be displayed.
3. Press either the  **ENTER** key or the  **DOWN** key until the “REMOTE DishScan TG” parameter is displayed.
4. Press the  **RIGHT** arrow to activate selection, then press the  Up arrow to toggle state to OFF. Press the  **ENTER** key (Note: You will see that an error code 16 is generated when DishScan movement is off.)

Using DacRemP:

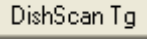
1. Click on the  icon in the Comm Diagnostics window. (Verify that DishScan is turned off by clicking the Error LED on main display panel, there should be a check mark next to Conscan/DishScan)





(Steps 2-7 will require assistance to observe and operate antenna simultaneously)

Step 2: At Antenna, If not already installed, place a circular level bubble on top lid of level cage.

Step 3: On the ACU front Panel, press either the  **ENTER** key or the  **DOWN** arrow key until the **REMOTE TILT** window is displayed

Step 4: Push the  **RIGHT** arrow key to activate the Remote Tilt Mode.

Step 5: Based on the feedback from the technician observing the circular bubble, the technician which operating the ACU will need to use the arrow keys to rotate the stabilized antenna mass from front to back and left to right. You should wait at least 10 seconds between commands to allow time for sensor to settle.

-  Left arrow will rotate antenna mass down to the left in the Cross-Level axis 1/2 degree
-  **Right** arrow will rotate antenna mass up to the right in the Cross-Level axis 1/2 degree
-  Up arrow will rotate antenna mass up in the Level axis 1/2 degree
-  **Down** arrow will rotate antenna mass down in the Level axis 1/2 degree

When correct the Bubble should be as close to the center of the fluid as possible.



Step 6: Press  **ENTER** key to exit Remote Tilt Mode.

Step 7: Verify Tilt Bias entered is within specifications.

From antenna:

2. Observe the bubble for approximately 3-5 minutes to ensure it remains centered.



Using DacRemP:

- Select the  reference sensor graph.

3. Verify the CL and LV displays are steady and within 4 divisions of nominal. (Anything more than 4 divisions above or below red reference line should be of concern and troubleshooting is required)

Step 8: Save Level and Cross-Level Tilt Bias values.

Using the DAC2202 ACU Front Panel:

4. Press  **DOWN** arrow or enter until you see “**REMOTE PARAMETERS**” window is displayed
- Press  **RIGHT** arrow and then press  **ENTER** key (you will see a confirmation saying ‘**SAVED**’)

Using DacRemP:

5. Click  icon on the Remote Command window. (Verify ^0087 is displayed in the “Last Sent Command” window)

This saves the new tilt bias settings in the PCU. Reset or re-initialize the antenna to verify that the Level cage is properly level with the new settings.

7.4.3. To Reset/Reinitialize the Antenna:

Pressing Reset on the ACU front panel does NOT cause a reset of the above decks equipment. To Re-initialize the antenna from the **REMOTE COMMAND** window on the ACU:

1. Using the **LEFT/RIGHT** and **UP/DOWN** arrow keys set the Remote Command value to “**0090**” and press **ENTER**.

This resets the PCU on the antenna. The antenna will reinitialize with this command (Performs a similar function as a power reset of the antenna).

7.5. Pedestal Control Unit Configuration (xx97B & xx00)

The PCU is designed to be used with a variety of antenna pedestal configurations. The configuration information that is unique to each pedestal type is stored in a Non Volatile Random Access Memory (NVRAM) in the PCU enclosure. If the PCU is replaced or the NVRAM in the PCU should become corrupt, the PCU must be re-configured to operate with the pedestal it is installed on. The default configuration for the PCU is model xx97B. In this configuration the PCU will not drive any of the three torque motors to prevent damage to the unknown pedestal.

To configure the PCU, select the REMOTE COMMAND window on the DAC-97 by pressing the MODE key until this window appears (if the DAC-97 will not advance beyond the REMOTE AUX window, enter 7979 and press ENTER). In the REMOTE COMMAND window, key in ". **7 8 ENTER**". An "N" should now appear in the command window. Refer to the table below to key in the appropriate value for you model antenna.

EXAMPLE: For an **9797B** Model Antenna:

1. Key in "**0208**" to select system type 208. The display should now show "N0208".
2. Press **ENTER** to send this system type command to the PCU.
3. Press **ENTER** several times to select **REMOTE PARAMETERS**. Press **UP** arrow and then **ENTER** to save the system type in the PCU.
4. Press ANTENNA, MODE, N/S to display the Remote Version Number. It should now display "9797B VER 1.8x".

7.5.1. MODEL CONFIGURATION NUMBERS

The following table shows the current mode configuration values for Series 97A pedestals.

MODEL	Configuration Number
xx97B	N 0000 <i>Turns off all drive motors</i>
9797B	N 0208
8797B	N 0209
9997B	N 0210
8897B	N 0211
12097B	N 0212
14497B	N 0213
14600B	N 0214
9497B	N 0215
9697B	N 0216
14400B	N 0217

7.6. Antenna Stowing Procedure



WARNING: Antenna Pedestal **must be properly restrained (stowed)** to prevent damage to wire rope isolators, isolator springs and/or antenna pedestal mechanism during underway conditions **when power is removed from the antenna assembly.**

The normal operating condition for the Sea Tel Antenna system is to remain powered up at all times. This ensures that the antenna remains actively stabilized to prevent physical damage to the antenna pedestal and reduce condensation and moisture in the radome to prevent corrosion. If, for some reason, the antenna must be powered down during underway transits, it should be secured with nylon straps regardless of sea conditions to prevent damage to the antenna system. Refer to the procedure below to secure the antenna pedestal.

Equipment & Hardware needed:

- Two (2) ½-13 x 2-inch Stainless Steel bolts.
- Two (2) Nylon straps with ratchet mechanism. **Nylon straps must be rated to 300 lbs. Working load capacity and 900 lbs. Max rated capacity.**

Stowing procedure:

1. Point the antenna to Zenith, (90 degree elevation angle), straight up.
2. Install one (1) ½-13 x 2-inch bolt into the inside of each elevation beam as shown in Figure 1.

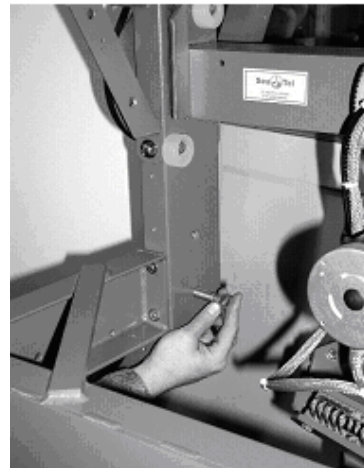

- Hook one end hook of the nylon strap to bolt in elevation beam as shown in Figure 2.



- Hook the other end hook of the nylon strap to the pedestal-mounting frame as shown in Figure 3.



- Use the ratchet of the strap to tighten nylon straps. As the straps are tightened, observe the vertical isolation canister assembly as shown in Figure 4.
- Tighten straps until the canister has been pulled down approx. $\frac{1}{4}$ to $\frac{1}{2}$ inch. Do not over-tighten. You must leave approximately $\frac{1}{8}$ inch clearance between the rubber stops and the azimuth driven sprocket to allow the vertical vibration isolation to function properly.

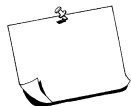
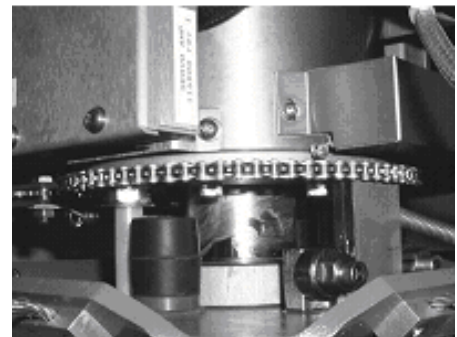

NOTE: Remove both *the straps and the bolts* **before applying power** and returning the antenna to normal operating condition.

8. 9497B-20 Technical Specifications

The technical specifications for your Series Above Decks Equipment subsystems are listed below: Refer to your ACU manual for its' Specifications.

8.1. 9497 Antenna Reflector

Type	Hydro Formed Aluminum Parabola
Diameter (D)	2.4 Meter (94 inches)
Focal Length	0.92 Meter (35.4 inches)
f/D	0.375 inch
Weight (bare)	26 kg (57 pounds)
RX Gain:	39.5 dB at 4.2 GHz
RX Gain:	47.5 dB at 12.5 GHz

8.2. Feed Assemblies

8.2.1. TVRO Quad Ku-Band Feed Assembly

Type:	Prime focus
Receive frequency:	10.7-11.7 GHz Ku Low Band 11.7-12.75 GHz Ku High Band
Quad Ku-Band LNB Assembly	
Type:	Quad output
LNB Manufacturer:	Brainwave, but may vary
	Low Band High Band
RF Frequencies:	10.7 - 11.7 GHz 11.7 - 12.75 GHz
IF Frequencies:	950 - 1950 MHz 1100 - 2150 MHz
LO Frequencies:	9.75 GHz 10.6 GHz
Noise Figure:	0.7 dB typical
Polarization modes:	2 Horiz., 2 Vert. Outputs
Band Selection:	2 Hi, 2 Lo band outputs
Polarization:	Linear, Simultaneous Dual Band-Dual Polarity Ku-Band (Horizontal & Vertical High band AND Horizontal & Vertical Low band)
Polang control:	24 volt DC motor with position feedback for Linear Mode

8.3. Pedestal Control Unit (PCU)

The PCU Assembly contains 1 Printed Circuit Board (PCB). It is the main control board.

Connectors	
Antenna Pedestal	44 Pin D-Sub connector
M&C Interface	15 Pin D-Sub connector
GPS Input	BNC connector
Controls	None
M&C Interface	9600 Baud RS-422

8.4. Stabilized Antenna Pedestal Assembly

Type:	Three-axis (Level, Cross Level and Azimuth)
Stabilization:	Torque Mode Servo
Stab Accuracy:	0.3 degrees MAX, 0.15 degrees RMS in presence of specified ship motions (see below).
LV & CL motors:	Size 34 Brushless DC Servo motor with integrated brake.
AZ motor:	Size 34 Brushless DC Servo motor with integrated encoder .
Inertial Reference:	Solid State Rate Sensors
Gravity Reference:	Two Axis Fluid Tilt Sensor
AZ transducer:	256 line optical encoder (integrated in AZ motor) / home switch
Range of Motion:	
Elevation	-15 to +110 degrees
Cross Level	+/- 25 degrees
Azimuth	Unlimited
Polarization	+/- 90 degrees
Elevation Pointing:	0 to +90 degrees (with 15 degree Roll) +5 to +90 degrees (with 20 degree Roll) +10 to +85 degrees (with 25 degree Roll)
Relative Azimuth Pointing	Unlimited
Specified Ship Motions (for stabilization accuracy tests):	
Roll:	+/- 15 degrees at 8-12 sec periods
Pitch:	+/- 10 degrees at 6-12 sec periods
Yaw:	+/- 8 degrees at 15 to 20 sec periods
Turning rate:	Up to 12 deg/sec and 15 deg/sec/sec
Headway:	Up to 50 knots
Mounting height:	Up to 150 feet.
Heave	0.5G
Surge	0.2G
Sway	0.2G
Maximum ship motion:	
Roll	+/- 25 degrees (Roll only) +/- 20 degrees (combined with Pitch)
Pitch	+/- 15 degrees
Yaw Rate	12 deg/sec, 15 deg/sec/sec

8.5. Unlimited Azimuth Modems (3 Channel)

Combined Signals	950-3000 MHz Ku-Band RX IF (less if not stacked), 3.7-4.2 GHz C-Band RX RF, 1.1/1.5, or 0.7/1.9, MHz FSK Pedestal M&C
Connectors:	
TX / RX IF	SMA Connector
Rotary Joint	SMA Connector
TVRO option	Type F
DC / Ped M&C	9 pin D-Sub Connector

8.6. 144" Radome Assembly

Type	Rigid dome
Material	Composite foam/fiberglass
Size	144" Diameter x 142" High
Base Hatch size	18" high x 34" wide
Side Door	18" wide x 36" high
Number of panels	Twelve panels (6 upper & 6 lower panels), one top cap and one base pan
Installed height:	164" including base frame if mounted with standard Legs, 148" if Flush-mounted
Installed weight	MAX 1800 LBS (including Antenna Pedestal Assembly)
RF attenuation	1.5 dB @ 6 GHz, dry 1.5 dB @ 12 GHz, dry 1.5 dB @ 14 GHz, dry
Wind:	Withstand relative average winds up to 100 MPH from any direction.
Ingress Protection Rating	All Sea Tel radomes have an IP rating of 56

NOTE: Radome panels can absorb up to 50% moisture by weight. Soaked panels will also have higher attenuation.

8.7. Environmental Conditions (ADE)

Temperature:	-20 degrees C to 55 degrees C.
Humidity:	Up to 100% @ 40 degrees C, Non-condensing.
Spray:	Resistant to water penetration sprayed from any direction.
Icing:	Survive ice loads of 4.5 pounds per square foot. Degraded RF performance will occur under icing conditions.
Rain:	Up to 4 inches per hour. Degraded RF performance may occur when the radome surface is wet.
Wind:	Withstand relative average winds up to 100 MPH from any direction.
Vibration:	Withstand externally imposed vibrations in all 3 axes, having displacement amplitudes as follows:
Frequency Range, Hz	Peak Single Amplitude
4 - 10	0.100 inches (0.1G to 1.0G)
10 - 15	0.030 inches (0.3G to 0.7G)
15 - 25	0.016 inches (0.4G to 1.0G)
25 - 33	0.009 inches (0.6G to 1.0G)
Corrosion	Parts are corrosion resistant or are treated to endure effects of salt air and salt spray. The equipment is specifically designed and manufactured for marine use.

8.8. Cables

8.8.1. Antenna Control Cable (Provided from ACU-MUX)

RS-422 Pedestal Interface

Type	Shielded Twisted Pairs
Number of wires	
Wire Gauge	24 AWG or larger
Communications Parameters:	9600 Baud, 8 bits, No parity
Interface Protocol:	RS-422
Interface Connector:	DE-9P

8.8.2. Antenna L-Band TVRO IF Coax Cables (Customer Furnished)

2, 4 or 6 cables are required dependant upon which feed/LNB configuration your antenna is fitted with. Due to the dB losses across the length of the RF coaxes at L-Band, Sea Tel recommends the following 75 ohm coax cable types (and their equivalent conductor size) for our standard pedestal installations:

Run Length	Coax Type	Conductor Size
up to 75 ft	LMR-300-75	18 AWG
up to 150 ft	RG-11 or LMR-400-75	14 AWG
up to 200 ft	LDF4-75 Heliax	10 AWG
Up to 300 ft	LMR-600-75	6 AWG

For runs longer than 300 feet, Sea Tel recommends Single-mode Fiber Optic Cables with Fiber Optic converters.

8.8.3. AC Power Cable (Pedestal & Rf Equipment)

Voltage:	110 or 220 volts AC (220 VAC Recommended)
Pedestal Power:	100 VA MAX
RF Equipment Power:	1500 VA MAX

8.8.4. Gyro Compass Interface Cable (Customer Furnished)

Type:	Multi-conductor, Shielded
Number of wires	4 Conductors for Step-By-Step Gyro, 5 Conductors for Synchro
Wire Gauge:	see Multi-conductor Cables spec above
Insulation:	600 VAC

8.8.5. Fiber Optic Transmitter (CFE Optional)

Model:	Ortel Model 3112A
Frequency Range:	950-2050 MHz
Noise Figure:	45 dB
Impedance:	75 ohm
Connectors:	
RF	Type F
Fiber	FC/APC "Tight Fit"

9. Model 9497B-20 Drawings

The drawings listed below are provided as part of this manual for use as a diagnostic reference. Spare Parts kits listings are provided as part number reference for replaceable parts and common assemblies.

9.1. Model Specific Drawings

Drawing	Title	
1282271-1_A	System, Model 9497B-20	9-3
128276-2_A	System Block Diagram – Model 9497B-20	9-5
128265-1_A	General Assembly – Model 9497B-20	9-8
128278_A	Antenna System Schematic – Model 9497B-20	9-10
128269-1_A	Antenna Assembly, 2.4M, Dual C/Quad Ku	9-11
125425-1_B	Feed Assembly, Dual C/Quad Ku	9-13
111365-17_N1	144" Radome Assembly	9-15
123723-1_B1	Radome Base Frame Assembly	9-17
123908_B1	Installation Arrangement	9-19

9.2. Series 97A & 00 General Drawings

Drawing	Title	
128545-1_A	Belt Kit, xx97B/xx00B	9-21
128546-1_A	Motor Kit, xx97B/xx00B	9-22
128547-1_A	Comprehensive Spare Parts Kit, xx97B/xx00B	9-23
126374_A	Pedestal Harness Schematic Model xx97B/xx00B	9-24
128303-1_A	Base MUX Rack Panel Assembly	9-25

This Page Intentionally Left Blank

SINGLE LEVEL MFG BILL OF MATERIAL

FIND	QTY	PART NO	REV	DESCRIPTION	REFERENCE DESIGNATOR
1	1 EA	128265-2	A	GENERAL ASS'Y, 9497B-20, TVRO	
2	1 EA	111365-17	N1	RADOME ASS'Y, 144 INCH, WHITE/SIDE A	
3	1 EA	123723-1	B1	RADOME BASE ASS'Y, 75 IN., STL, NO AC,	
4	1 EA	128273-1	A	ANTENNA ASS'Y, 9497B-20 TVRO	
5	1 EA	125411-2	G	DAC-2202, DVB RCVR, 9 WIRE IF	(NOT SHOWN)
6	1 EA	128279-1	X1	BELOW DECK KIT, 4CH, TVRO	(NOT SHOWN)
11	1 EA	128188-3		CUSTOMER DOC PACKET, 9497B-20, TVR	(NOT SHOWN)
12	1 EA	122539-1	B	SHIP STOWAGE KIT, XX97	(NOT SHOWN)
13	1 EA	114569	D	BALANCE WEIGHT KIT	(NOT SHOWN)
14	1 EA	124877-1	A	DECAL KIT, XX97, SEATEL (126 IN/144 IN R	(NOT SHOWN)

				
SYSTEM, 9497B-20, TVRO				
PROD FAMILY 97 TVRO	EFF. DATE 02-Sep-08	SHT 1 OF 1	DRAWING NUMBER 128271-1	REV A

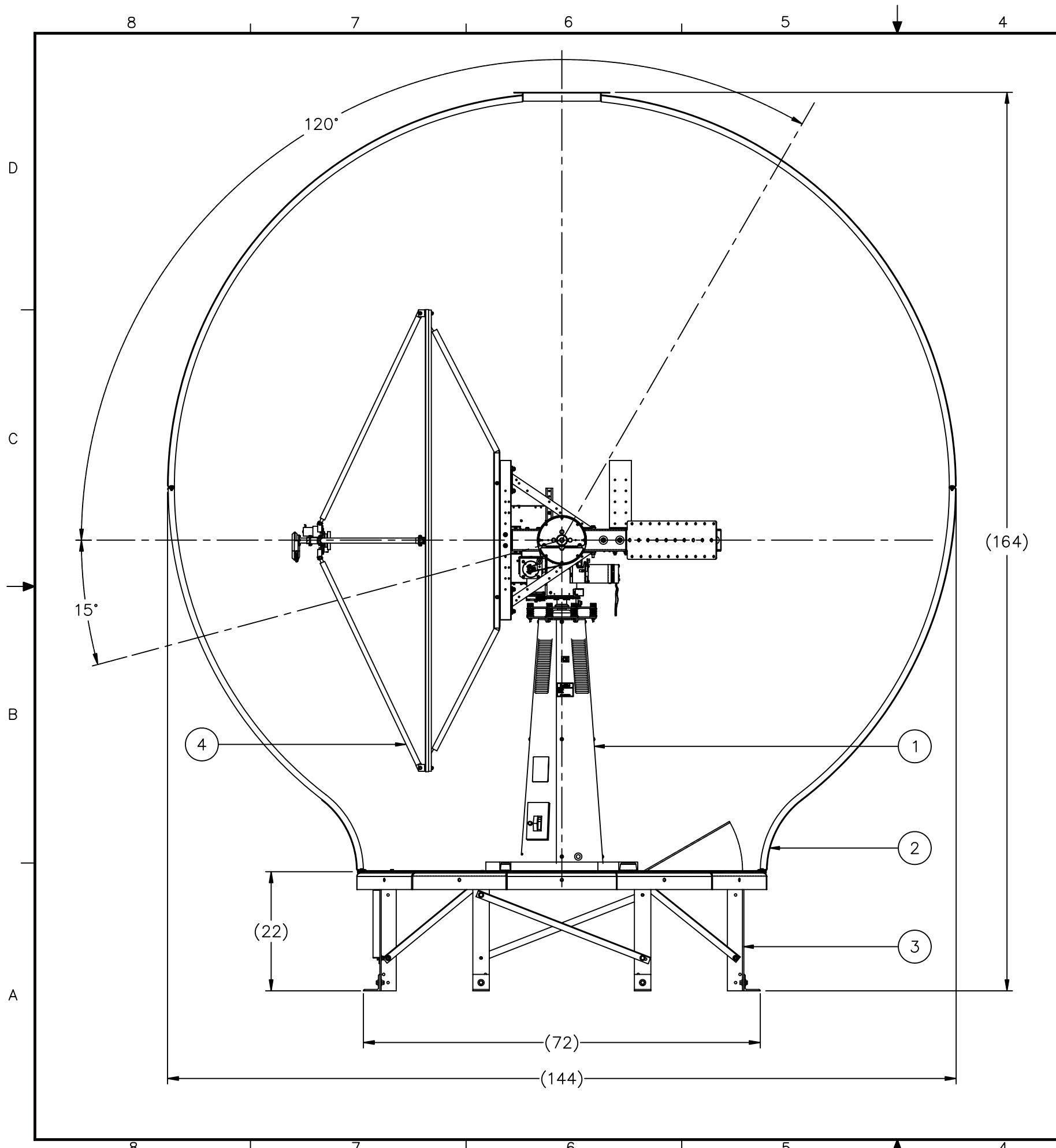

REVISION HISTORY				
REV	ECO#	DATE	DESCRIPTION	BY
A	N/A	8-13-08	RELEASED TO PRODUCTION, WAS REV X1.	SMS

REFERENCE DRAWINGS:

- 128276 SYSTEM BLOCK DIAGRAM.
- 128278 ANTENNA SYSTEM SCHEMATIC.
- 126374 PEDESTAL HARNESS SCHEMATIC.
- 123908 INSTALLATION ARRANGEMENT
- 124877 DECAL KIT, XX97

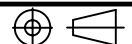
TOLERANCES UNLESS OTHERWISE SPECIFIED X.X = ±.050 X.XX = ±.020 X.XXX = ±.005 ANGLES: ±.5° INTERPRET TOLERANCING PER ASME Y14.5M - 1994		DRAWN BY: SMS DRAWN DATE: 5-27-08 APPROVED BY:	 4030 NELSON AVENUE CONCORD, CA 94520 Tel. 925-798-7979 Fax. 925-798-7986
MATERIAL: N/A FINISH: N/A	APPROVED DATE: SIZE: B SCALE: 1 : 20	TITLE: SYSTEM, 9497B-20, TVRO DRAWING NUMBER: 128271 REV: A	
3rd ANGLE PROJECTION 		FIRST USED: 9497B-20	SHEET NUMBER: 1 OF 1

SINGLE LEVEL MFG BILL OF MATERIAL

FIND	QTY	PART NO	REV	DESCRIPTION	REFERENCE DESIGNATOR
1	1 EA	128265-2	A	GENERAL ASS'Y, 9497B-20, TVRO	
2	1 EA	111365-17	N1	RADOME ASS'Y, 144 INCH, WHITE/SIDE A	
3	1 EA	128273-1	A	ANTENNA ASS'Y, 9497B-20 TVRO	
4	1 EA	124143-1	A1	FEED ASS'Y, KU-DISHSCAN, DUAL RX, 97	
5	2 EA	122386	D	FILTERED LNB ASS'Y, QUAD, XX98, XX04	
20	1 EA	117168-1	N1	MODEM ASS'Y, PEDESTAL, 3 CH, 75 OHM	
21	1 EA	115708-3	H3	CIRCUIT BREAKER BOX ASS'Y, 97 220V	
22	1 EA	125570-4	E	POWER SUPPLY ASS'Y, COSEL 150W, RH	
23	1 EA	127513-1	B	PCU ASS'Y, XX97B, STD	
24	1 EA	116024-1	J2	SHIELDED POLANG RELAY ASS'Y	
25	3 EA	116000-1	J1	SERVO AMPLIFIER ASS'Y	
26	1 EA	122208-1	J	LEVEL CAGE ASS'Y, 90 DEG EL RANGE, IN	
27	1 EA	121966-6	D1	GPS ANTENNA, RETERMINATED, 32.0 L	
28	1 EA	116034	F	HOME SWITCH ASS'Y, SHIELDED	
30	1 EA	121425-3	D4	HARNESS ASS'Y, INTERFACE, 4006	
31	1 EA	126375-3	X2	HARNESS ASS'Y, PEDESTAL	
32	1 EA	121485-1	F	HARNESS ASS'Y, REFLECTOR	
33	1 EA	125726-3	A3	HARNESS ASS'Y, BRAKE, 56 IN, XX07	
40	1 EA	127940-2	A	POWER RING ASS'Y, 22 IN, 96 IN. CONTAC	
41	1 EA	124288-96	F	CABLE ASS'Y, AC POWER, 96 IN	
50	7 EA	109391	A	F BULLET	
51	1 EA	127968-1	A1	ROTARY JOINT, 4RF-2DC	
60	1 EA	128252-14		HARNESS ASS'Y, 4 CH, RG-6, F(M) TO F(M)	
61	1 EA	128385-60BLU	X1	CABLE ASS'Y, RG-179, COAX, SMA (RA) T	
62	1 EA	127963-60GRN	A	CABLE ASS'Y, RG-179 COAX, F TO F(RA), 6	
63	1 EA	127963-60WHT	A1	CABLE ASS'Y, RG-179 COAX, F TO F(RA), 6	
64	1 EA	127963-60RED	A	CABLE ASS'Y, RG-179 COAX, F TO F(RA), 6	
100	1 EA	125411-2	G	DAC-2202, DVB RCVR, 9 WIRE IF	
101	1 EA	128279-1	X1	BELOW DECK KIT, 4CH, TVRO	

				
SYSTEM BLOCK DIAGRAM, 9497B-20				
PROD FAMILY LIT	EFF. DATE 02-Sep-08	SHT 1 OF 2	DRAWING NUMBER 128276-2	REV A

SINGLE LEVEL MFG BILL OF MATERIAL

FIND	QTY	PART NO	REV	DESCRIPTION	REFERENCE DESIGNATOR
102	1 EA	128303-1	A	BASE MODEM RACK PANEL ASS'Y, 4CH T	
103	1 EA	116676	B2	TERMINAL MOUNTING STRIP ASS'Y, ACU	
105	1 EA	117168-2	N1	MODEM ASS'Y, BASE, 3 CH, 75 OHM	
110	1 EA	120643-25	A	CABLE ASS'Y, RS232, 9-WIRE, STRAIGHT,	
111	1 EA	116298-1	F4	HARNESS ASS'Y, ACU TO MUX	
112	1 EA	119479-10	B	CABLE ASS'Y, CAT5 JUMPER, 10 FT.	
116	1 EA	128001-8BLU	A	CABLE ASS'Y, RG-179 COAX, F(M) TO SMA	
117	1 EA	128253-6	X2	HARNESS ASS'Y, 4 CH, RG-59, F(M) TO F(
118	1 EA	111115-6	B	CABLE ASS'Y, F(M)-F(M), 6 FT.	
120	4 EA	109391	A	F BULLET	

				
SYSTEM BLOCK DIAGRAM, 9497B-20				
PROD FAMILY LIT	EFF. DATE 02-Sep-08	SHT 2 OF 2	DRAWING NUMBER 128276-2	REV A

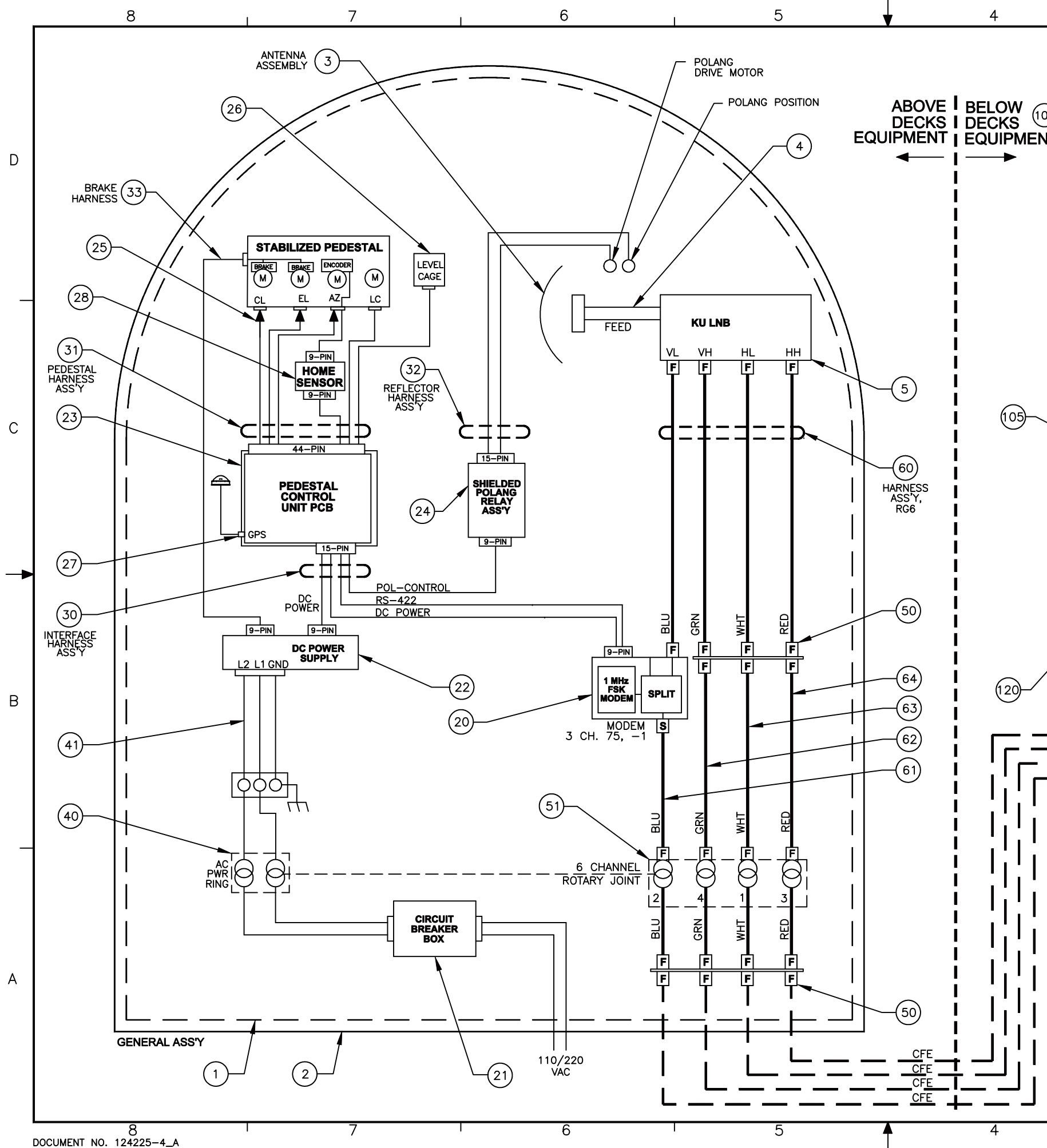

REVISION HISTORY				
REV	ECO#	DATE	DESCRIPTION	BY

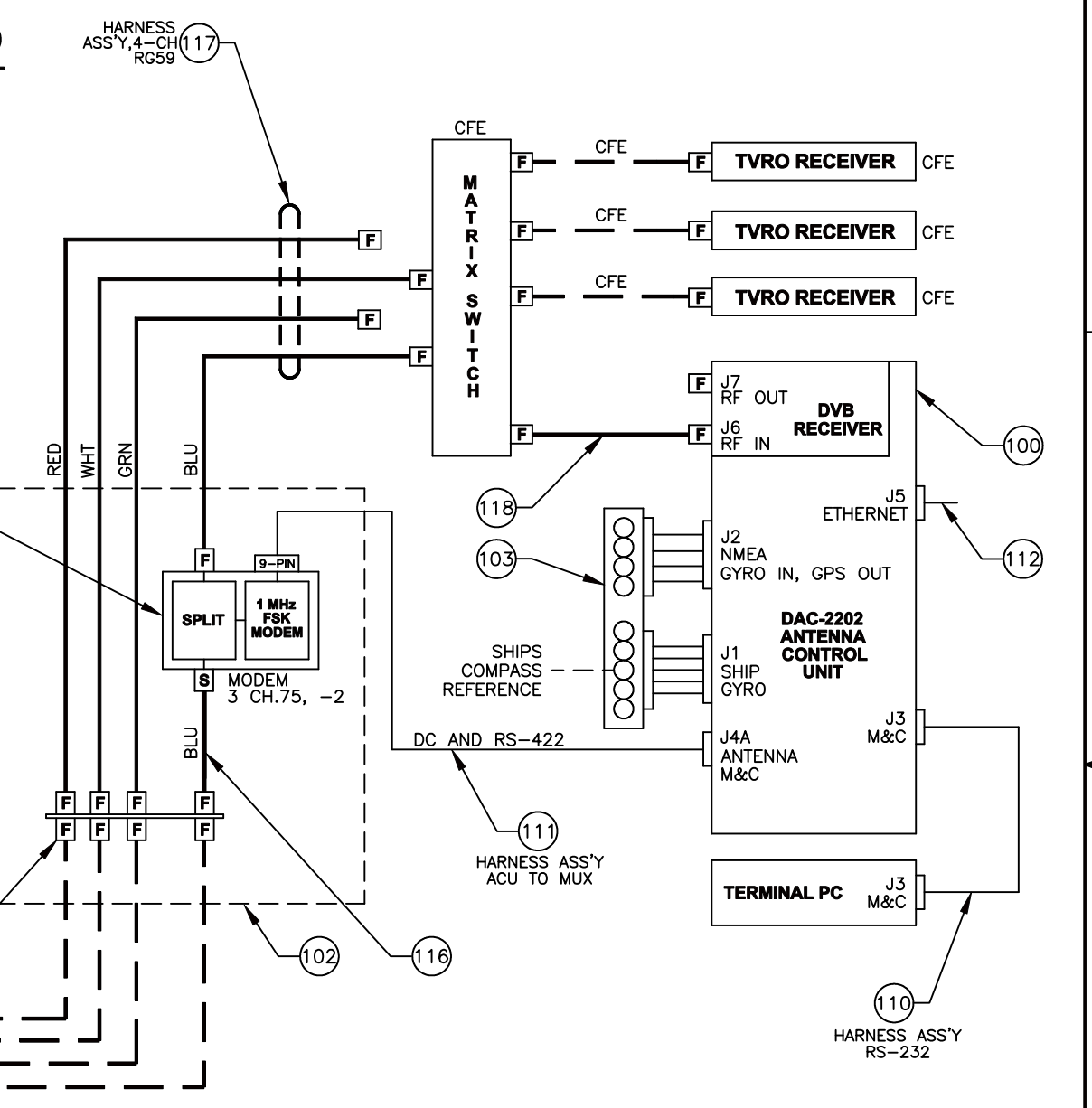

DASH #	MODEL NO.	SYSTEM
-5	14400B-20	N/A
-3	12097B-20	N/A
-2	9497B-20	128271
-1	8897B-20	128272

REFERENCE DRAWINGS

126374 PEDESTAL SYSTEM SCHEMATIC

128278 ANTENNA SYSTEM SCHEMATIC

TOLERANCES UNLESS OTHERWISE SPECIFIED		DRAWN BY: SMS		<p>4030 NELSON AVENUE CONCORD, CA 94520 Tel. 925-798-7979 Fax. 925-798-7986</p>	
X.X = ±.050 X.XX = ±.020 X.XXX = ±.005 ANGLES: ±.5°		DRAWN DATE: 5-28-08			
INTERPRET TOLERANCING PER ASME Y14.5M - 1994		APPROVED BY:		TITLE: SYSTEM BLOCK DIAGRAM XX97B-20	
MATERIAL: N/A		APPROVED DATE:		DRAWING NUMBER: 128276	
FINISH: N/A		SIZE: B	SCALE: NONE	REV: A	
3rd ANGLE PROJECTION		FIRST USED: XX97B-20		SHEET NUMBER: 1 OF 1	

SINGLE LEVEL MFG BILL OF MATERIAL

FIND	QTY	PART NO	REV	DESCRIPTION	REFERENCE DESIGNATOR
1	1 EA	128286-1	X1	PEDESTAL ASS'Y, 94/96/99 FOR 97B	
2	1 EA	128515-2	X1	POWER ASS'Y, 220V, 45 IN. SHROUD	
3	1 EA	128267-2	A	ELECT. EQ. FRAME, XX97B-20, TVRO	
9	1 EA	121655-1	C1	LABELS INSTALLATION	
10	1 EA	123530-2	B	GROUND BONDING KIT, XX97	(NOT SHOWN)

				
GENERAL ASS'Y, 9497B-20, TVRO				
PROD FAMILY 97 TVRO	EFF. DATE 02-Sep-08	SHT 1 OF 1	DRAWING NUMBER 128265-2	REV A

8 7 6 5 4 3 2 1

REVISION HISTORY				
REV	ECO#	DATE	DESCRIPTION	BY
A	N/A	8-04-08	ITEM 2 P/N WAS 121605-2; REMOVED ITEMS 16 & 17; WAS REV X1.	SMS

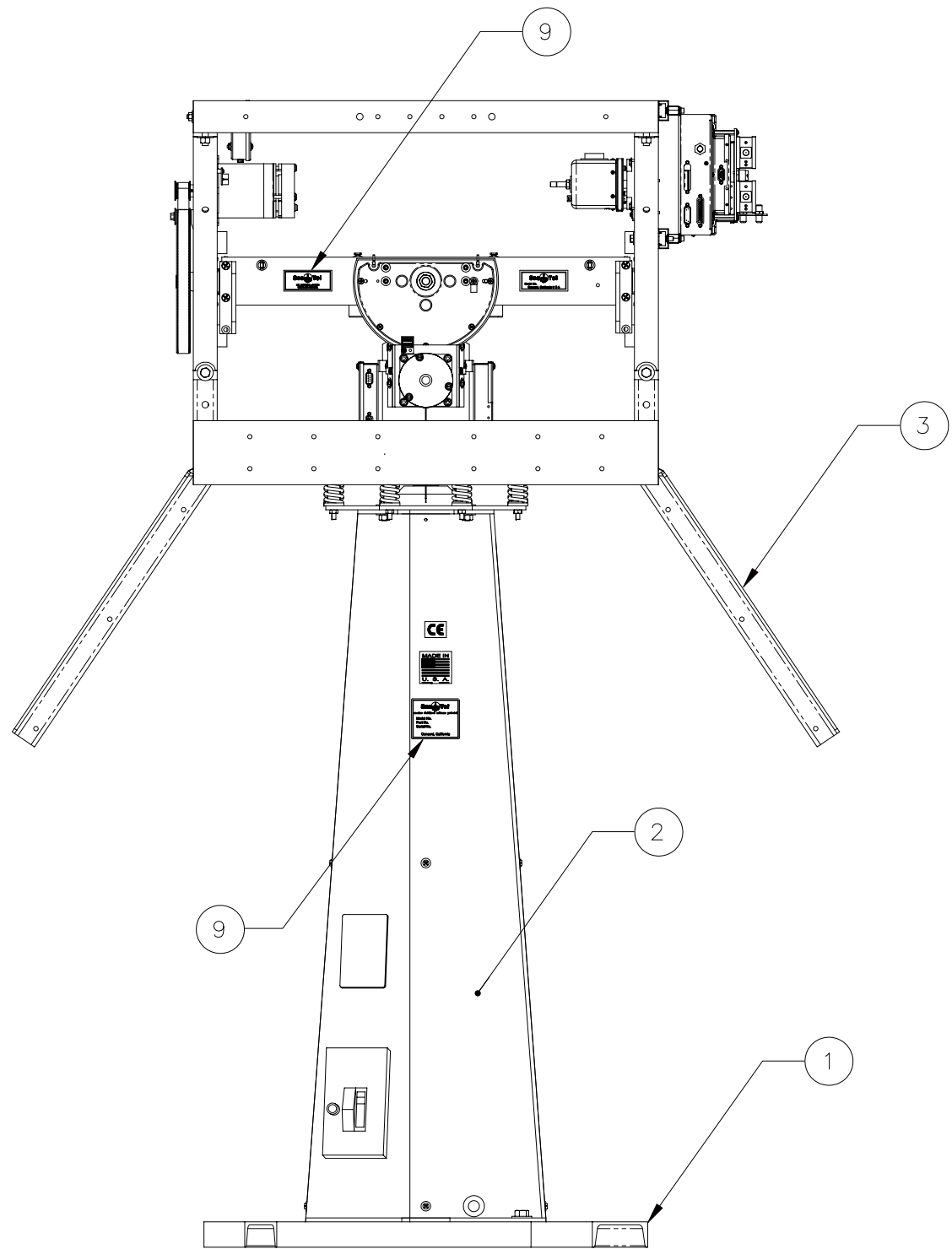

REFERENCE DRAWINGS
 128181 SYSTEM BLOCK DIAGRAM
 126374 PEDESTAL SCHEMATIC
 128268 ANTENNA SYSTEM SCHEMATIC

DASH	DESCRIPTION	SHOWN
-3	9497B-1 & -2, TVRO	
-2	9497B-20, TVRO	
-1	9497B-21, TVRO	SHOWN

TOLERANCES UNLESS OTHERWISE SPECIFIED X.X = ±.050 X.XX = ±.020 X.XXX = ±.005 ANGLES: ±.5° INTERPRET TOLERANCING PER ASME Y14.5M - 1994		DRAWN BY: SMS DRAWN DATE: 5-22-08		 4030 NELSON AVENUE CONCORD, CA 94520 Tel. 925-798-7979 Fax. 925-798-7986	
MATERIAL: N/A		APPROVED BY:			
FINISH: N/A		APPROVED DATE:		TITLE: GENERAL ASS'Y, 9497B	
3rd ANGLE PROJECTION		SIZE: B	SCALE: NONE	DRAWING NUMBER: 128265	REV: A
FIRST USED: 9497B-21			SHEET NUMBER: 1 OF 1		

D
C
B
A

D
C
B
A

8 7 6 5 4 3 2 1

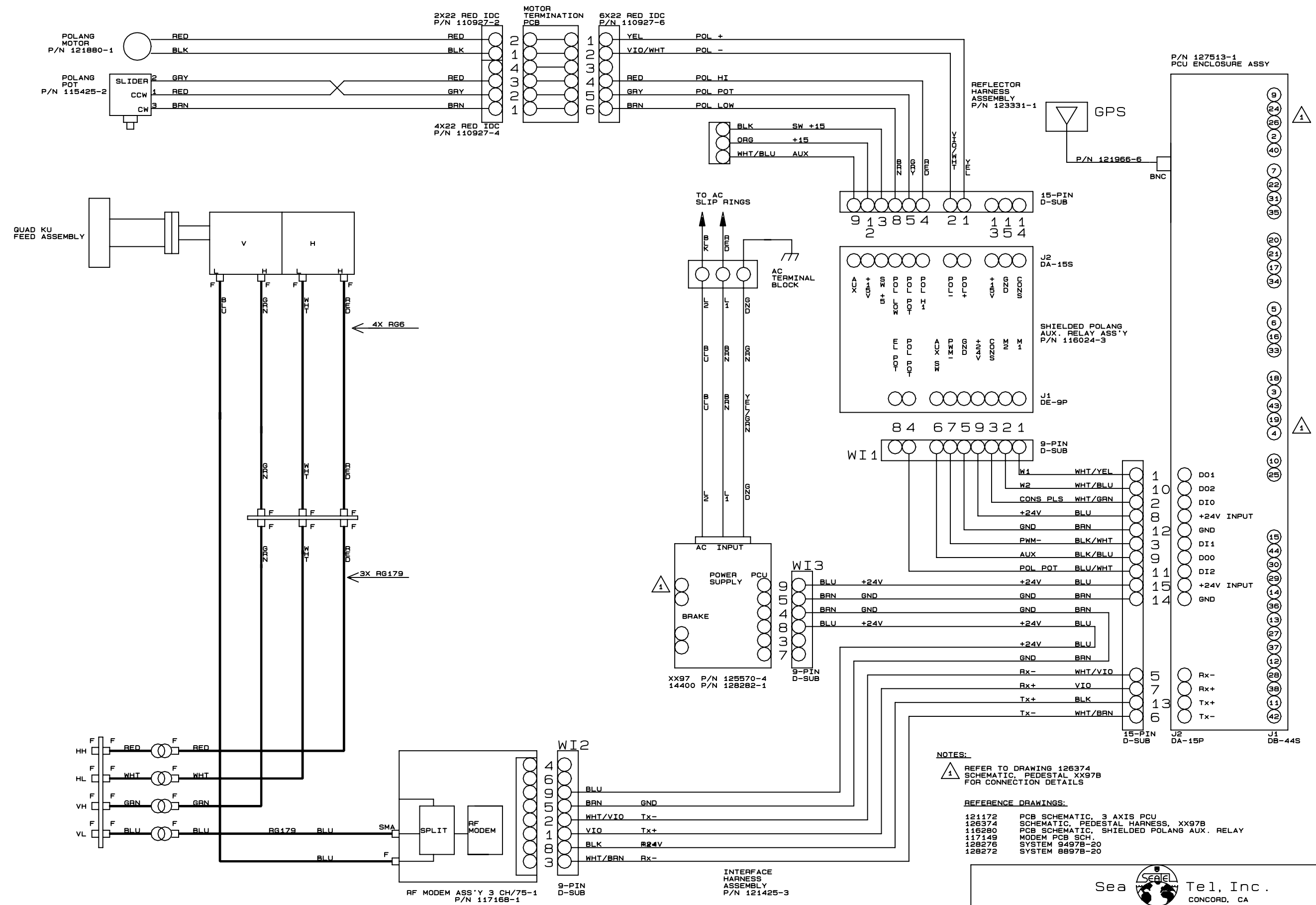

NOTES:
 1 REFER TO DRAWING 126374 SCHEMATIC, PEDESTAL XX97B FOR CONNECTION DETAILS

- REFERENCE DRAWINGS:**
- 121172 PCB SCHEMATIC, 3 AXIS PCU
 - 126374 SCHEMATIC, PEDESTAL HARNESS, XX97B
 - 116280 PCB SCHEMATIC, SHIELDED POLANG AUX. RELAY
 - 117149 MODEM PCB SCH.
 - 128276 SYSTEM 9497B-20
 - 128272 SYSTEM 8897B-20

SCALE: NONE	APPROVED BY:	DRAWN BY MSF
DATE: 7-30-08		DRAWING SIZE: C
ANTENNA SYSTEM SCHEMATIC QUAD KU-BAND RX ONLY/4CH		
MODEL: XX97B-20 14400B-20	SHT. 1 OF 1	DRAWING NUMBER REV. 128278 A

SINGLE LEVEL MFG BILL OF MATERIAL

FIND	QTY	PART NO	REV	DESCRIPTION	REFERENCE DESIGNATOR
1	1 EA	110174-3		REFLECTOR, 2.4M, CUSTOM BACKFRAME	
2	4 EA	115446-2	P2	FEED STRUT ASS'Y, 45.00 IN	
3	1 EA	125425-1	B	FEED ASS'Y, DUAL C/QUAD KU, DISHSCA	
5	4 EA	126433-2	A	BLOCK, REFLECTOR MOUNTING	
6	1 EA	123331-1	B3	HARNESS ASS'Y, REFLECTOR	(NOT SHOWN)
7	1 EA	128254-14	X2	HARNESS ASS'Y, 6 CH, RG-6, F(M) TO F(M)	(NOT SHOWN)
8	10 EA	119801-019	B	CABLE TIE, NYLON, 7.5 IN, NATURAL	(NOT SHOWN)
51	4 EA	114586-541		SCREW, HEX HD, 1/4-20 x 1-1/2, S.S.	
52	4 EA	114586-542		SCREW, HEX HD, 1/4-20 x 1-3/4, S.S.	
53	4 EA	114583-029		NUT, HEX, 1/4-20, S.S.	
54	12 EA	114580-029		WASHER, FLAT, 1/4, S.S.	
60	8 EA	114586-627		SCREW, HEX HD, 3/8-16 x 1-3/4, S.S.	
61	16 EA	114580-031	A	WASHER, FLAT, 3/8, S.S.	
62	8 EA	114583-031		NUT, HEX, 3/8-16, S.S.	

				
ANTENNA ASS'Y, 9497B-21 TVRO				
PROD FAMILY COMMON	EFF. DATE 02-Sep-08	SHT 1 OF 1	DRAWING NUMBER 128269-1	REV A

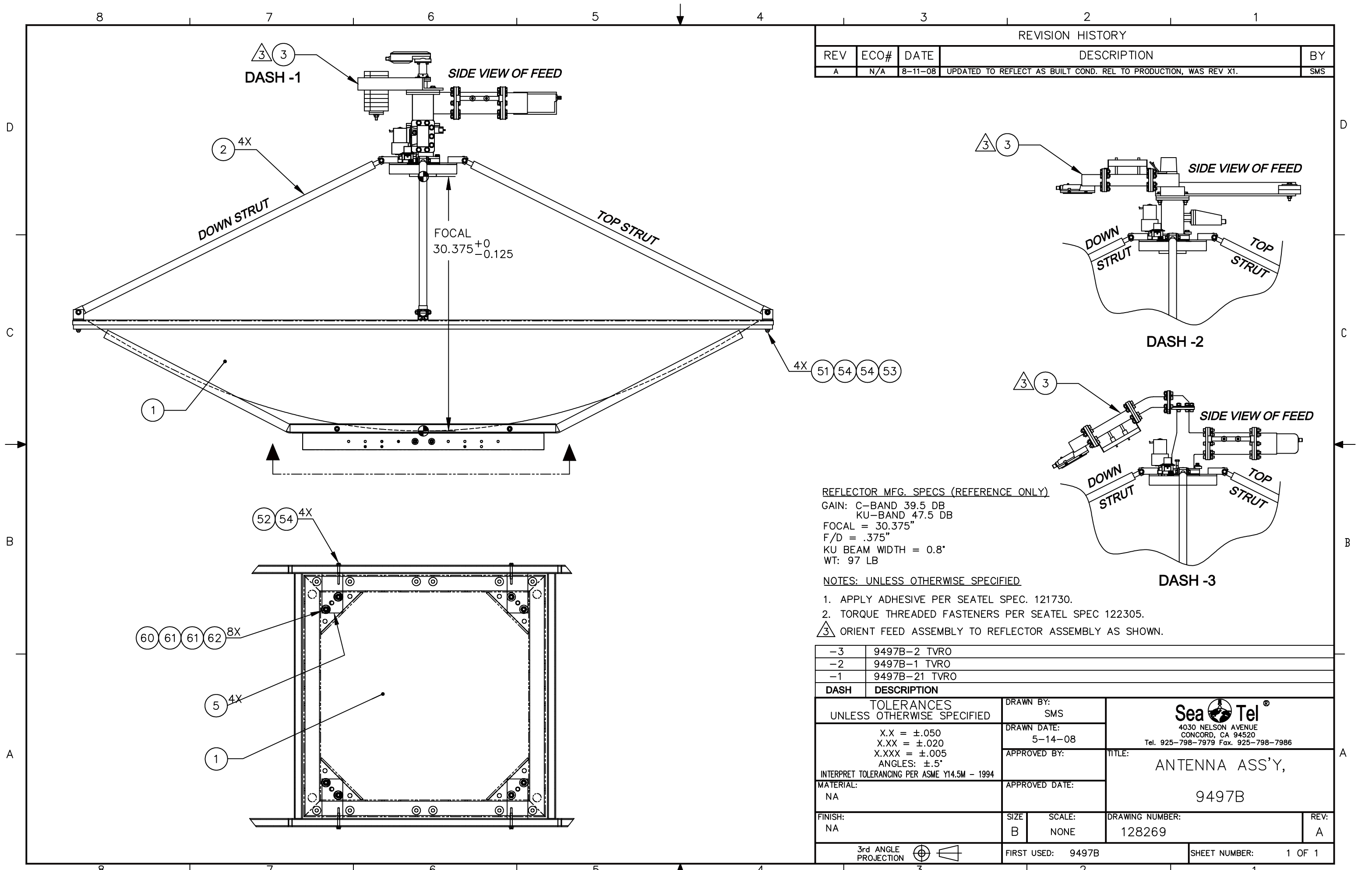

REVISION HISTORY				
REV	ECO#	DATE	DESCRIPTION	BY
A	N/A	8-11-08	UPDATED TO REFLECT AS BUILT COND. REL TO PRODUCTION, WAS REV X1.	SMS

REFLECTOR MFG. SPECS (REFERENCE ONLY)
 GAIN: C-BAND 39.5 DB
 KU-BAND 47.5 DB
 FOCAL = 30.375"
 F/D = .375"
 KU BEAM WIDTH = 0.8°
 WT: 97 LB

- NOTES: UNLESS OTHERWISE SPECIFIED
- APPLY ADHESIVE PER SEATEL SPEC. 121730.
 - TORQUE THREADED FASTENERS PER SEATEL SPEC 122305.
- △ ORIENT FEED ASSEMBLY TO REFLECTOR ASSEMBLY AS SHOWN.

-3	9497B-2 TVRO
-2	9497B-1 TVRO
-1	9497B-21 TVRO

DASH	DESCRIPTION	DRAWN BY:	Sea Tel®	
		SMS	4030 NELSON AVENUE CONCORD, CA 94520 Tel. 925-798-7979 Fax. 925-798-7986	
TOLERANCES UNLESS OTHERWISE SPECIFIED		DRAWN DATE: 5-14-08	TITLE: ANTENNA ASS'Y, 9497B	
X.X = ±.050 X.XX = ±.020 X.XXX = ±.005 ANGLES: ±.5° INTERPRET TOLERANCING PER ASME Y14.5M - 1994		APPROVED BY:		
MATERIAL: NA		APPROVED DATE:	DRAWING NUMBER: 128269	
FINISH: NA		SIZE: B	SCALE: NONE	REV: A
3rd ANGLE PROJECTION		FIRST USED: 9497B	SHEET NUMBER: 1 OF 1	

SINGLE LEVEL MFG BILL OF MATERIAL

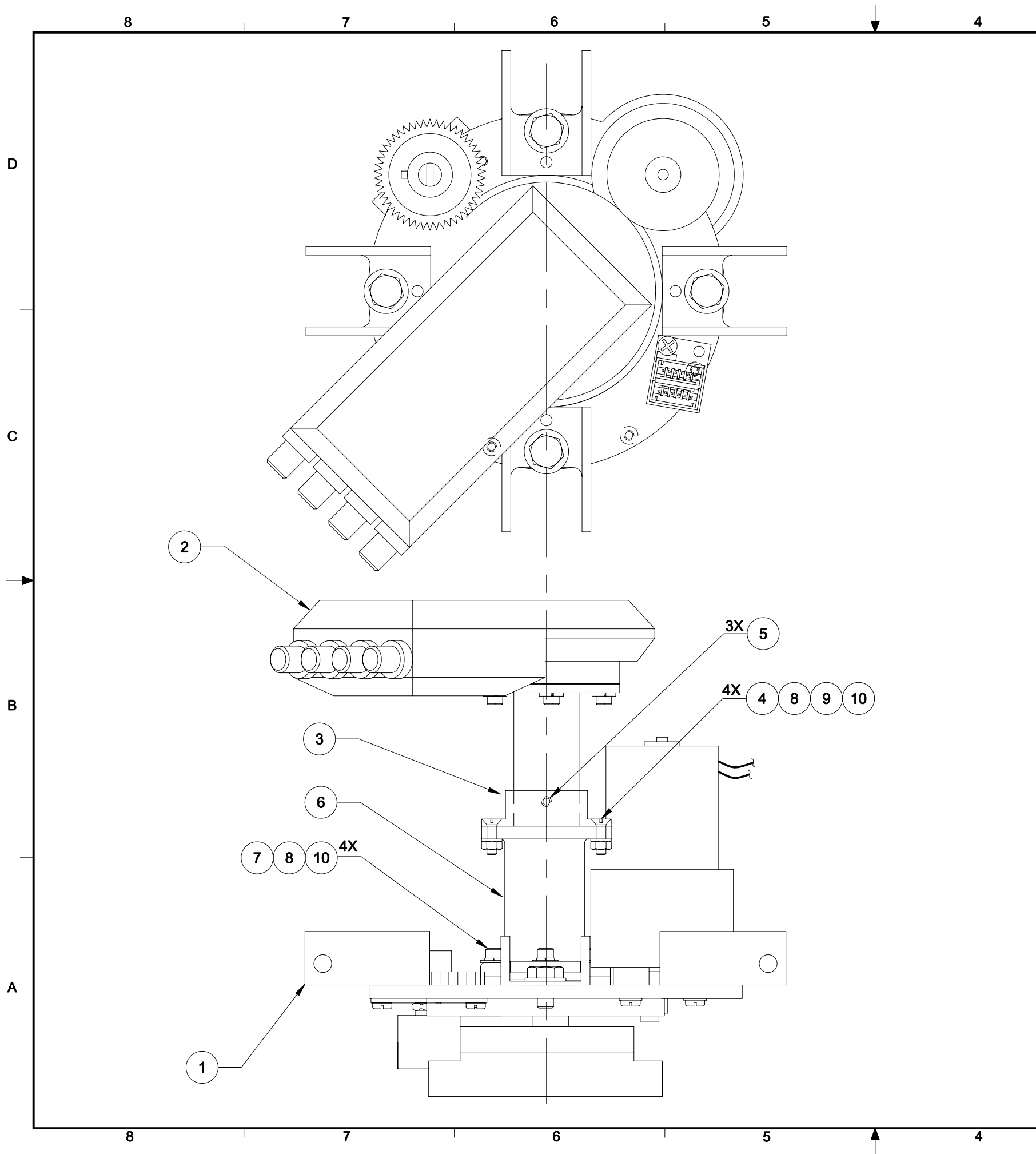

FIND	QTY	PART NO	REV	DESCRIPTION	REFERENCE DESIGNATOR
1	1 EA	124141-1	B	FEED ASS'Y, BASIC KU-DISHSCAN, 96/97	
2	1 EA	122386	D	FILTERED LNB ASS'Y, QUAD, XX98, XX04	
3	1 EA	113648-1	J	FEED ADAPTER PLATE	
4	4 EA	114576-148		SCREW, FLAT HD, PHIL, 6-32 x 1/2 S.S.	
5	3 EA	114590-189		SCREW, SOCKET SET-CUP, 8-32 x 3/16, S.	
6	1 EA	120560	B	FILTER, MICROWAVE	
7	4 EA	114593-123		SCREW, SOCKET HD, 6-32 x 7/16, S.S.	
8	8 EA	114581-007		WASHER, LOCK, #6, S.S.	
9	4 EA	114583-007		NUT, HEX, 6-32, S.S.	
10	8 EA	114580-008		WASHER, FLAT, #6, SMALL PATTERN, S.S.	

				
FEED ASS'Y, KU-DISHSCAN, DUAL RX, 97				
PROD FAMILY COMMON	EFF. DATE 02-Sep-08	SHT 1 OF 1	DRAWING NUMBER 124143-1	REV A1



REVISION HISTORY				
REV	ECO#	DATE	DESCRIPTION	BY
A	6140	04-10-08	REMOVE NOTE 2. ITEM 7 WS 114593-124. RELEASE TO PRODUCTION. REV WS X4.	SL
A1	N/A	8-11-08	UPDATED VIEW & ADDED TOP VIEW TO REFLECT AS BUILT CONDITION.	SMS

NOTES, UNLESS OTHERWISE SPECIFIED:
 1. APPLY ADHESIVE PER SEATEL DOC # 121730.

TOLERANCES UNLESS OTHERWISE SPECIFIED X.X = ±.050 X.XX = ±.020 X.XXX = ±.005 ANGLES: ±.5° INTERPRET TOLERANCING PER ASME Y14.5M - 1994	DRAWN BY: L.R.	 4030 NELSON AVENUE CONCORD, CA 94520 Tel. 925-798-7979 Fax. 925-798-7986
	DRAWN DATE: 3-23-05	
MATERIAL: -	APPROVED BY:	Ku-BAND, LNBF
FINISH: -	APPROVED DATE:	DRAWING NUMBER 124143
3rd ANGLE PROJECTION 	SIZE: B SCALE: 1/1	REV A1
FIRST USED: --		SHEET NUMBER 1 of 1

SINGLE LEVEL MFG BILL OF MATERIAL

FIND	QTY	PART NO	REV	DESCRIPTION	REFERENCE DESIGNATOR
	12 EA	117762-1	B	SILICONE ADHESIVE, WHT RTV 122, 10.1	NOT SHOWN
	1 EA	110327	M	HARDWARE KIT, 144 INCH RADOME	NOT SHOWN
1	1 EA	109119-17	F2	RADOME FAB ASS'Y, 144 INCH, WHITE/SID	
9	3 EA	124903-1	B1	STRAIN RELIEF ASS'Y	
11	0 EA	114586-538		SCREW, HEX HD, 1/4-20 x 1, S.S.	INCLUDED IN HARDWARE KIT
12	0 EA	114586-541		SCREW, HEX HD, 1/4-20 x 1-1/2, S.S.	INCLUDED IN HARDWARE KIT
14	0 EA	114625-107		WASHER, FENDER, 1/4, (1 IN OD), S.S.	INCLUDED IN HARDWARE KIT
17	0 EA	114583-029		NUT, HEX, 1/4-20, S.S.	INCLUDED IN HARDWARE KIT
28	1 EA	109783-2		WRENCH, L	

				
RADOME ASS'Y, 144 INCH, WHITE/SIDE ACCESS				
PROD FAMILY COMMON	EFF. DATE 02-Sep-08	SHT 1 OF 1	DRAWING NUMBER 111365-17	REV N1

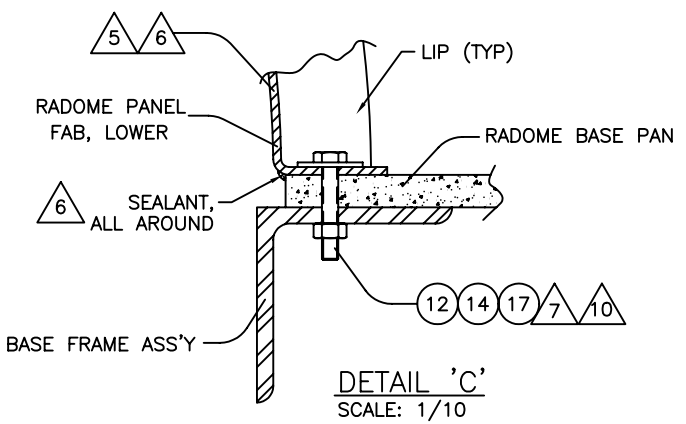
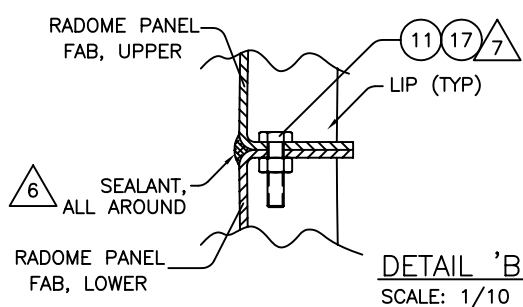
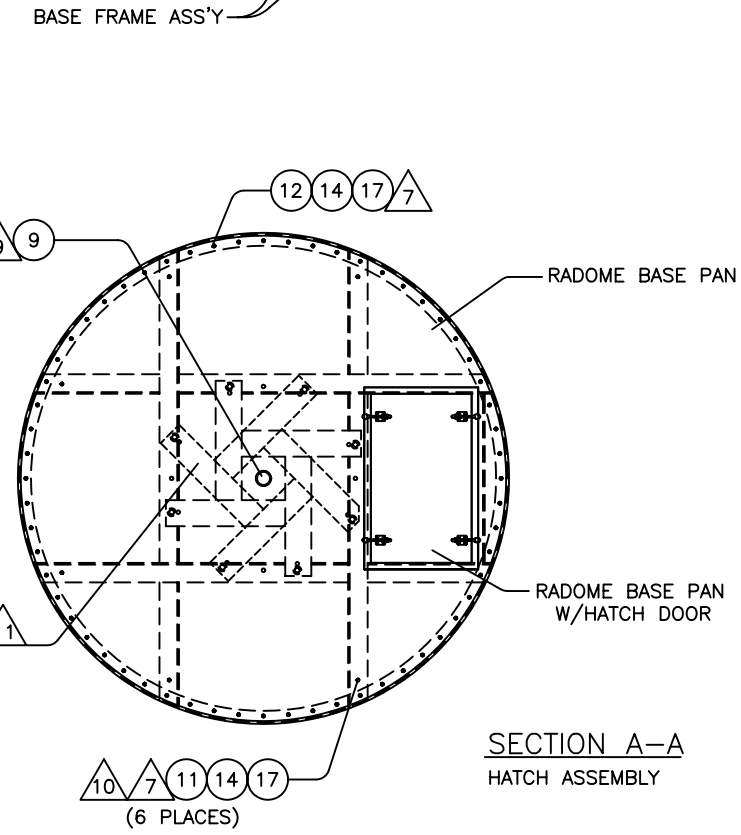
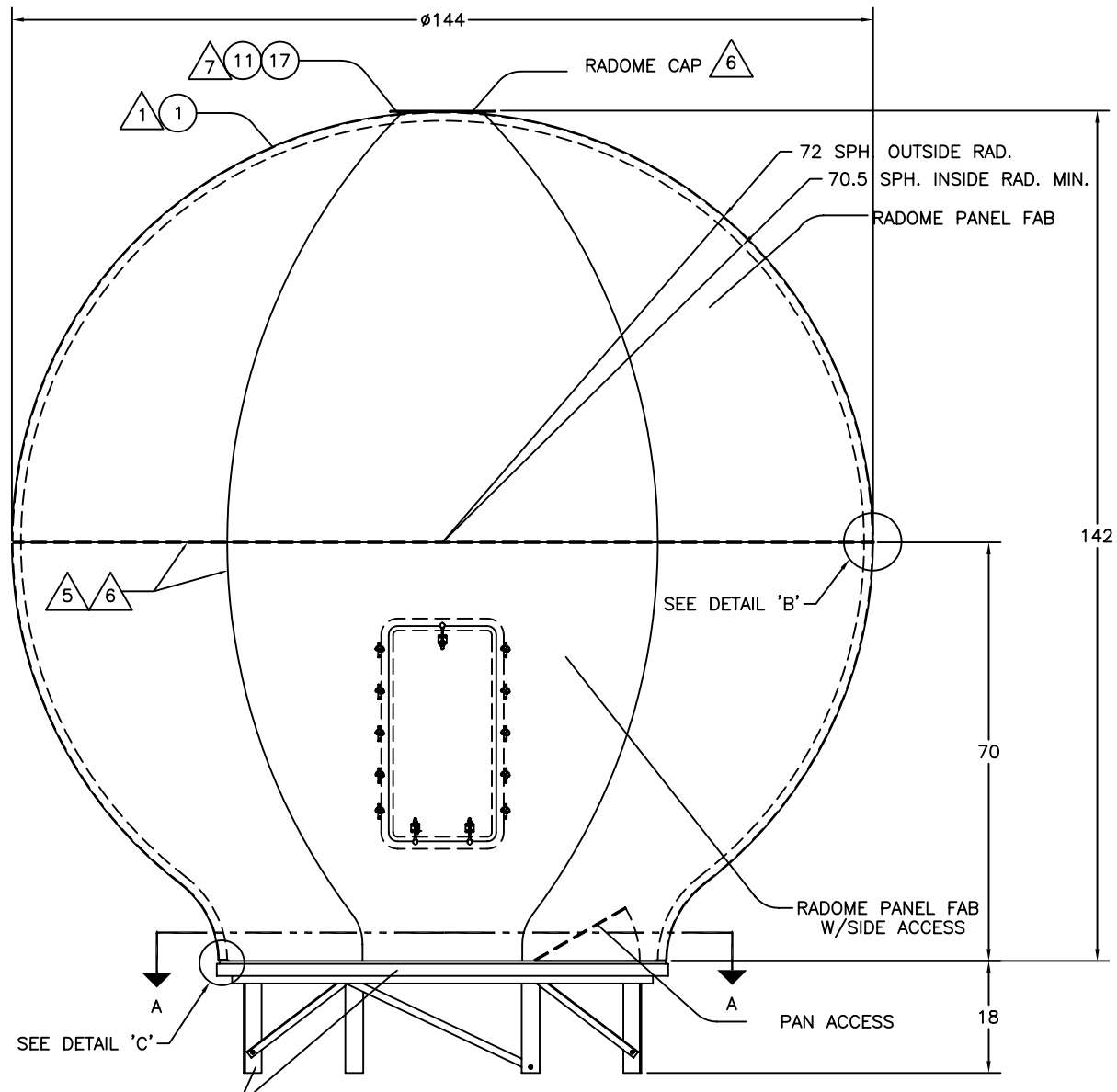

REV.	ECO#	DATE	DESCRIPTION	BY
D		6-13-97	REDRAWN; REV. C FILED OBSOLETE.	MAB
E		5-13-98	ITEM 5 P/N 110965-6 ADD'D.	MAB
F		6-23-98	BASE STAND MOUNTING LOCATION ADD'D TO SECTION A-A; NOTE 12 ADD'D.	MAB
G		7-8-98	DASH No's 9-16 ADD'D; NOTES 2 & 3 CHG'D FOR CORRECT BASE PAN & DASH No's.	MAB
H		5-24-99	ITEM 21 ADD'D.	CF
I		1-5-00	DASH No's 17-24 & PAN ACCESS CLMN ADD'D TO DASH TABLE; NOTES 2C & 2D ADD'D; ITEM 1 P/N's 109119-17 THRU -24 ADD'D.	MAB
J	3900	4-7-03	ADD'D ADDITIONAL LATCH TO SIDE DOOR; NOTE 5 " APPLYING GASKET"; ITEMS 19, 20 & 22 ; AND DASH 25. RENUMBERED NOTE ITEMS & CORRECTED BALLOONS. FOR ASSY W/SIDE ACCESS: CHG LATCH 108959 ITEM 31 TO QTY 3; SCREW 114587-829 ITEM 19 TO QTY 12; WASHER 114580-011 ITEM 20 TO QTY 12; NUT 114583-011 ITEM 22 TO QTY 12. FOR ASSY W/SIDE & PAN ACCESS: CHG ITEM 31 TO QTY 7; ITEM 19 TO QTY 28; ITEM 20 TO QTY 28 & ITEM 22 TO QTY 28.	LK
K	4083	10-08-03	CHANGED STRAIN RELIEFS FROM 109258-1 TO 109258-8. UPDATED BOM & DWG NOTES, BALLOON #'S & QTY TO MATCH CURRENT BUILD. REARRANGED DASH TABLE.	LK
L	4490	07-26-04	MOVE HW FOR SIDE ACCESS TO RADOME FAB ASSY. DEL ITEMS 19-20,22,29-33,35,SHEET 2.	AMN
M	4941	07-14-05	SILICON ADHESIVE CHANGED TO CLEAR FOR DASH 21.	V.S.
M1	N/A	9-6-05	ADDED DASH 28	LK
N	5050	11-7-05	STRAIN RELIEF WAS 109258-8	LK
N1	N/A	10-17-07	ADDED DASH 27	CK

DASH NO'S	CONFIGURATION		
	COLOR	FOAM	SIDE ACCESS
-1	WHITE	YES	YES
-17	WHITE	YES	YES
-18	WHITE	YES	YES
-21	US NAVY GREY	YES	YES
-25	BRIT GREY	YES	YES
-26	DANISH NAVY GREY	YES	YES
-27	SNOW WHITE	YES	YES

- NOTES:
- SELECT RADOME FAB ASS'Y 109119 AS PER SPECIFICATIONS IN CUSTOMERS SALES ORDERS.
 - N/A.
 - N/A.
 - APPLY ADHESIVE PER SEATEL SPEC. 121730.
 - APPLY MASKING TAPE ALONG VERTICAL AND HORIZONTAL EDGES OF ALL PANELS PRIOR TO CAULKING.
 - USE SILICON ADHESIVE TO SEAL VERTICAL AND HORIZONTAL EDGES OF ALL PANELS, RADOME CAP, AND ON BASE PAN UNDER PANELS.
 - APPLY ADHESIVE AS PER SEATEL SPEC 121730 TO ALL THREADED FASTENERS AT TIME OF FINAL ASSEMBLY AND TIGHTEN WITH TORQUE WRENCH PER FOLLOWING TABLE:

BOLT DIA.	THREAD PITCH	FT. LBS.	THREAD PITCH	FT. LBS.
1/4"	20	5.5	28	6.0
5/16"	18	10.0	24	11.4
3/8"	16	21.7	24	24.5
7/16"	14	32.4	20	38.4
1/2"	13	43.5	20	54.6
9/16"	12	57.5	18	68.0
5/8"	11	86.0	18	102.0
3/4"	10	152.0	16	182.0

- BASED ON WIND VELOCITY OF 100 MPH:
HORIZONTAL WIND SHEAR: 870 FT. LBS.
VERTICAL LIFT EACH LEG MAX.: 580 FT. LBS.
OVERTURNING MOMENT: 6,380 FT. LBS.
- INSTALLED BY CUSTOMER (REQUIRED HOLE SIZE ϕ 1.28).
- MATCH DRILL AT ASSEMBLY.
- ORIENTATION OF BASE STAND ASSEMBLY WHEN USED WITH COOLING UNIT ASSEMBLY, REFERENCE GENERAL ASSEMBLY.

TOLERANCES UNLESS OTHERWISE SPECIFIED X.X = $\pm .050"$ X.XX = $\pm .020"$ X.XXX = $\pm .005"$ ANGLES = $\pm 30'$			
SCALE: 1/20 DATE: 6-13-97 TITLE: RADOME ASSEMBLY, 144"		APPROVED BY: _____ DRAWN BY: MAB DRAWING SIZE: C	
3rd ANGLE PROJECTION		MODEL: 144" RADOME	SHEET: 1 OF 1 DRAWING NUMBER: 111365 REVISION: N1

SINGLE LEVEL MFG BILL OF MATERIAL

FIND	QTY	PART NO	REV	DESCRIPTION	REFERENCE DESIGNATOR
1	1 EA	123724-1	B	RADOME BASE FRAME ASS'Y, 75 IN, STEE	
2	1 EA	123726-1	B1	RADOME BASE PAN FAB, WHITE	
3	1 EA	123728-2	A	RADOME PAN ACCESS ASS'Y, WHITE	
50	6 EA	114586-540		SCREW, HEX HD, 1/4-20 x 1-1/4, S.S.	
52	12 EA	114580-029		WASHER, FLAT, 1/4, S.S.	
53	6 EA	114583-029		NUT, HEX, 1/4-20, S.S.	

				
RADOME BASE ASS'Y, 75 IN., STL, NO AC, WHT PAN				
PROD FAMILY COMMON	EFF. DATE 02-Sep-08	SHT 1 OF 1	DRAWING NUMBER 123723-1	REV B1

NOTES: (UNLESS OTHERWISE SPECIFIED)

1. APPLY ADHESIVE PER SEA TEL SPEC. 121730.

REV.	ECO#	DATE	DESCRIPTION	BY
A	N/A	1-14-05	RELEASED TO PRODUCTION	AMN
A1	NONE	04-13-05	-9 ADDED	AEF
A2	NONE	04-29-05	-9 BASE FRAME WS STL. LG. FOOT, BASE PAN WS P/N 123726-2	MSF
B	4888	05-31-05	FOR -5, -6, -8, -9 BASE PAN WAS P/N 123726-1.	V.S.
B1	N/A	01-24-07	ADD INTERNAL AC PAN FAB CUTOUTS (NOT PREVIOUSLY SHOWN).	SL.

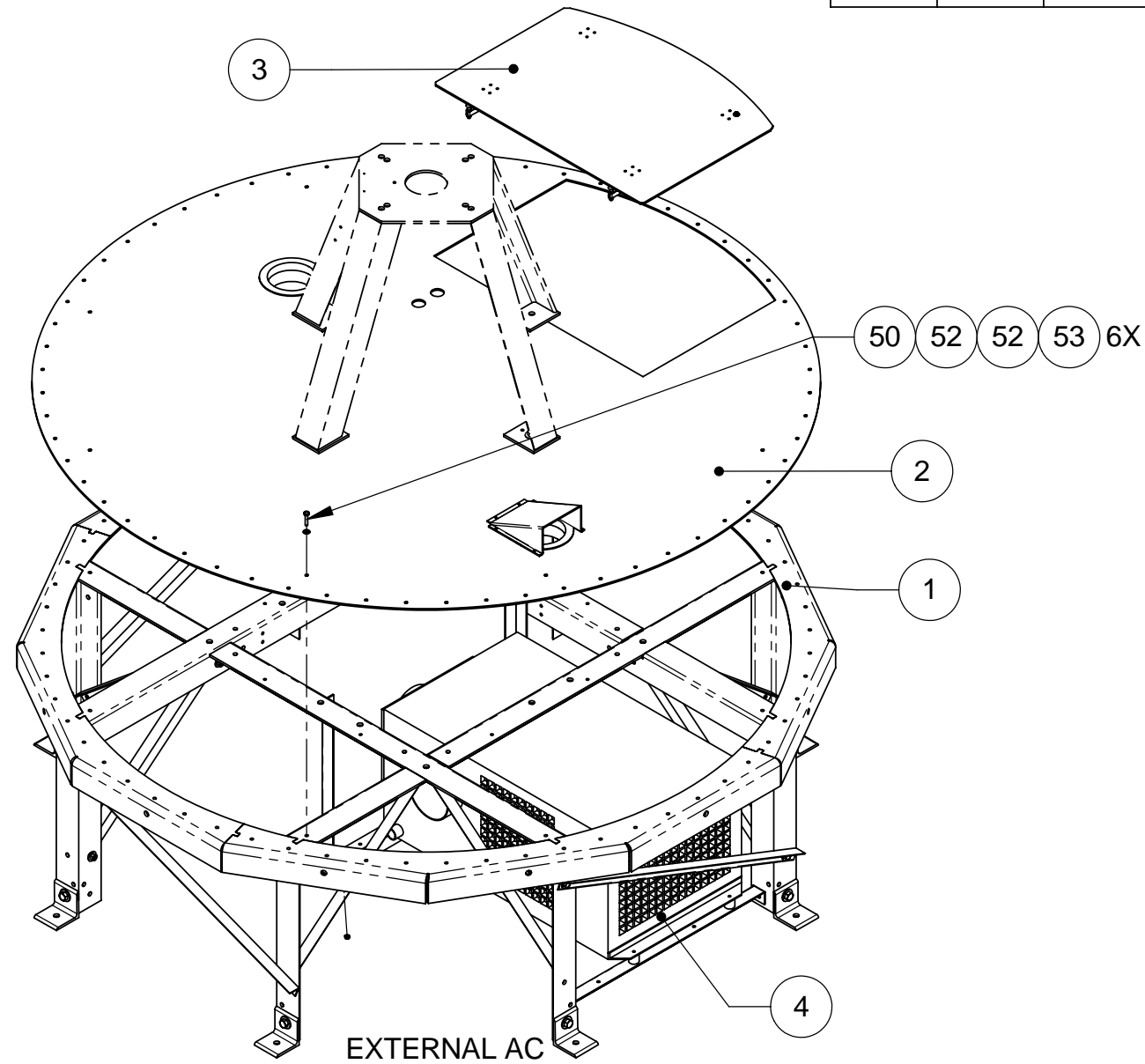

HEX SCREW, 1/4-20 X 1.25
 FLAT WASHER
 FLAT WASHER
 NUT
 6 PLCS.

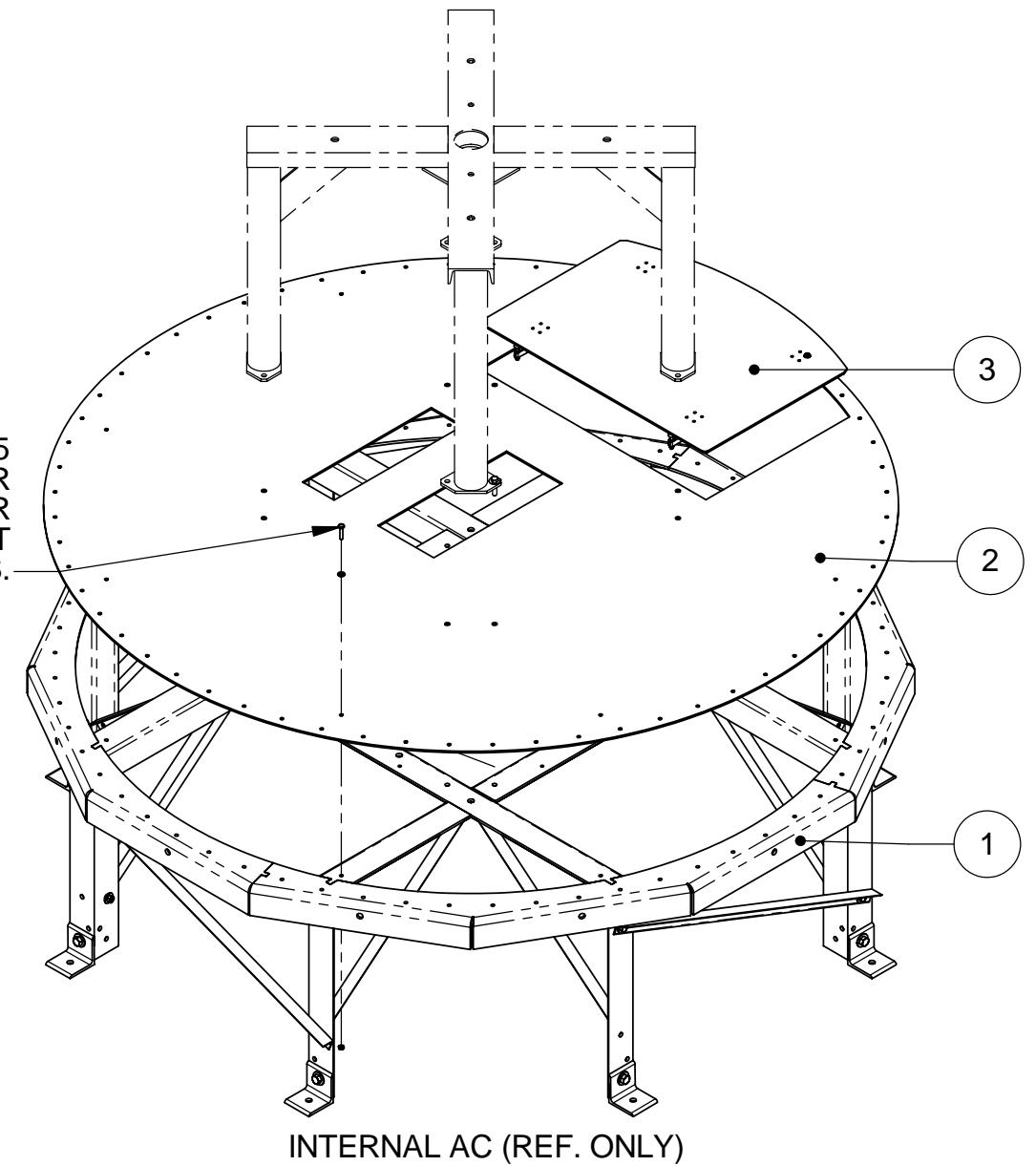

DASH #	BASE FRAME	AC OPTION	COLOR	BASE PAN	BASE PAN ACCESS ASSY
-1	STL.	NO	WHITE	123726-1	123728-2
-2	AL.	NO	WHITE	123726-1	123728-2
-3	STL.	NO	US NAVY GREY	123726-2	123728-3
-4	STL.	NO	BRT GREY	123726-3	123728-4
-5	STL.	EXTERNAL	WHITE	124458-1	123728-2
-6	AL.	EXTERNAL	WHITE	124458-1	123728-2
-7	STL. LG. FOOT	NO	WHITE	123726-1	123728-2
-8	STL. LG. FOOT	EXTERNAL	WHITE	124458-1	123728-2
-9	STL	INTERNAL	WHITE	124459-1	123728-2

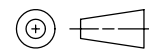
TOLERANCES UNLESS OTHERWISE SPECIFIED		 SCALE: 1:16 DATE: 12-14-04 APPROVED BY: _____ DRAWN BY: SCC DRAWING SIZE: B			
X.X	= ± .050"				
X.XX	= ± .020"	TITLE: RADOME BASE ASSY, 75 IN.			
X.XXX	= ± .005"				
ANGLES = ± 30' 3rd ANGLE PROJECTION 		MODEL: XX97	SHEET: 1 OF 1	DRAWING NUMBER: 123723	REVISION: B1

NOTES: (UNLESS OTHERWISE SPECIFIED)

1. ALL WEIGHTS GIVEN ARE FOR INFORMATION ONLY.
DO NOT USE FOR DESIGN. REFER TO 121910.
2. SEATEL DOES NOT PROVIDE LIFTING HARDWARE OR STRAPS.

REVISION HISTORY				
REV	ECO#	DATE	DESCRIPTION	BY
B1	N/A	11-1-05	SHT. 2: TABLE 1 MODEL 9797A-50 WEIGHT WS 720; MODEL 9797A-59, 56, 66, 62 & 8797A-29 WEIGHT ADDED	MSF

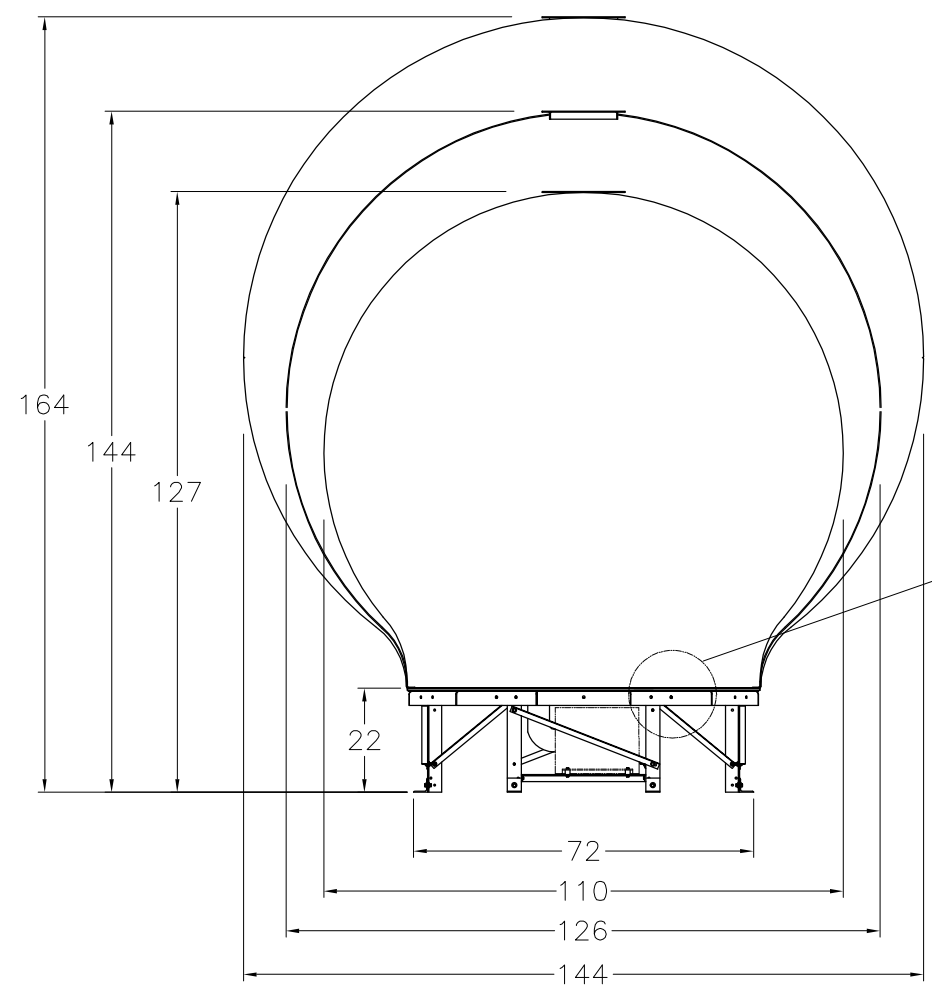
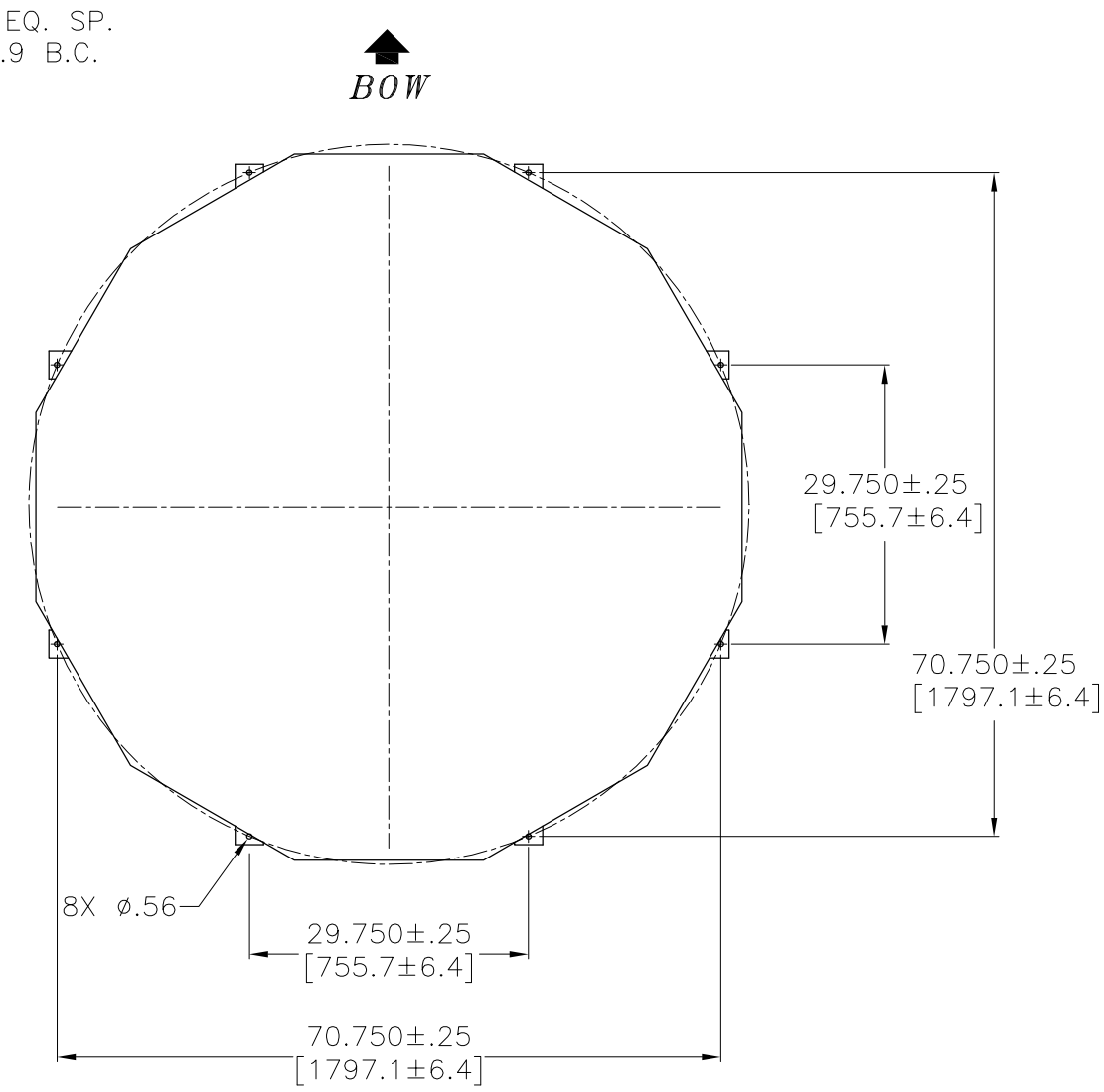
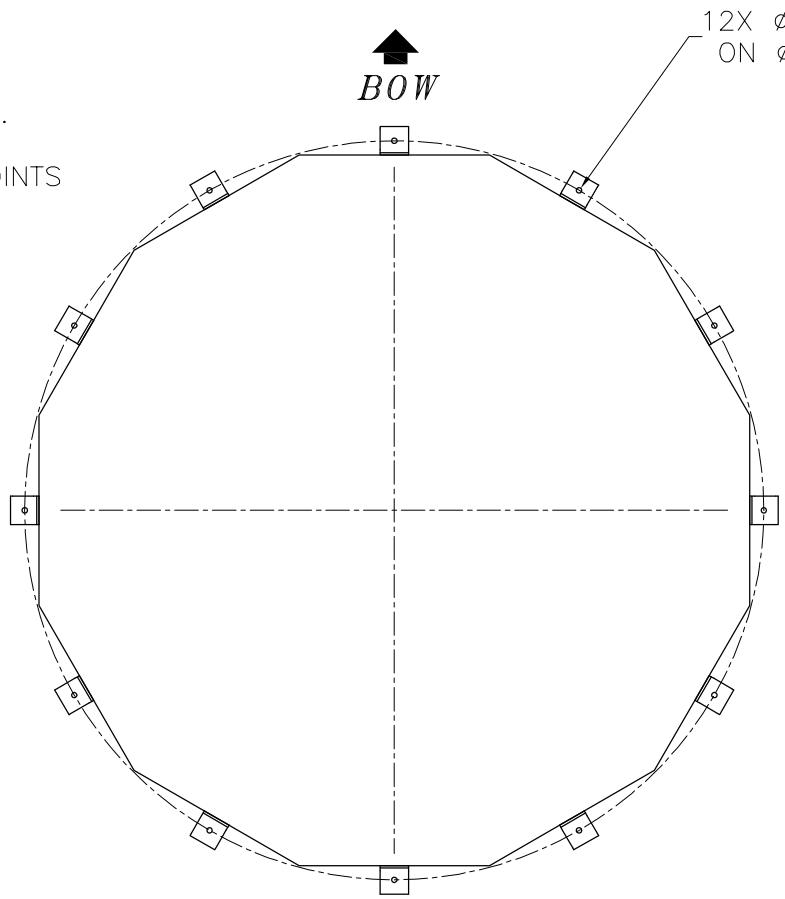
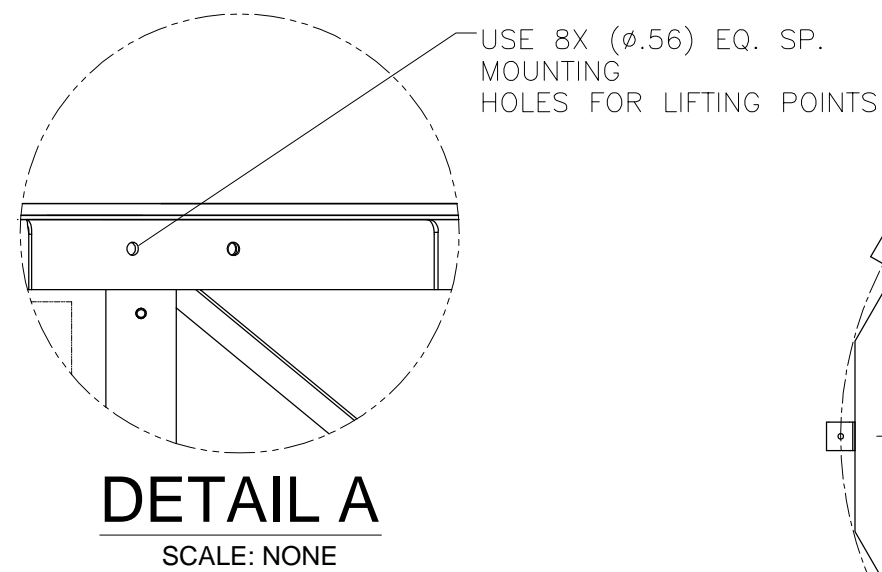

SEE DETAIL A

<p>TOLERANCES UNLESS OTHERWISE SPECIFIED</p> <p>X.X = ±.050 X.XX = ±.020 X.XXX = ±.005 ANGLES: ±.5° INTERPRET TOLERANCING PER ASME Y14.5M - 1994</p>	<p>DRAWN BY: SCC</p>	<p>SeaTel® 4030 NELSON AVENUE CONCORD, CA 94520 Tel. 925-798-7979 Fax. 925-798-7986</p>
	<p>DRAWN DATE: 01-03-05</p>	
<p>MATERIAL:</p>	<p>APPROVED BY:</p>	<p>DRAWING NUMBER: 123908</p>
<p>FINISH:</p>	<p>APPROVED DATE:</p>	<p>REV: B1</p>
<p>3rd ANGLE PROJECTION</p>	<p>SIZE: B</p> <p>SCALE: 1:20</p>	<p>FIRST USED: XX97A</p> <p>SHEET NUMBER: 1 OF 2</p>

8

7

6

5

4

3

2

1

D

D

TABLE 1: GENERAL ASSEMBLY WEIGHT

ITEM DESCRIPTION	NET* WEIGHT (LB.)
9797A-09	455
9797A-11	565
9797A-21	555
9797A-27	575
9797A-32	625
9797A-38	615
9797A-40	545
9797A-43 (Dual C-Band)	720
9797A-45	545
9797A-46	625
9797A-49	485
9797A-50	565
9797A-51	685
9797A-53	695
9797A-59	545
12097A-2	585
9797A-56	565
8797A-29	645
9797A-66	555
9797A-62	685

*NET WEIGHT EXCLUDES SHIPPING PALLET WEIGHT OF APPROX. 25 LB.

TABLE 2: BASE ASSEMBLY WEIGHT

ITEM DESCRIPTION	WEIGHT (Lb.) **
BASE ASSEMBLY: STEEL BASE, 21" LEGS	309
BASE ASSEMBLY: AL BASE, 21" LEGS	-
BASE ASSEMBLY: STEEL BASE, FLUSH MOUNT	-
BASE ASSEMBLY: AL BASE, FLUSH MOUNT	-

**ADD 100lbs FOR AIR CONDITIONER ASSEMBLY.

TABLE 3: RADOME ASSEMBLY WEIGHT

ITEM DESCRIPTION	WEIGHT (Lb.) ***
RADOME ASSEMBLY: 110" (DRY WEIGHT)	TBD
RADOME ASSEMBLY: 126" (DRY WEIGHT)	TBD
RADOME ASSEMBLY: 144" (DRY WEIGHT)	TBD

***WEIGHT GIVEN IS APPROXIMATE DRY WEIGHT. RADOME PANELS CAN ABSORB UP TO 50% MOISTURE BY WEIGHT.

C

C

B

B

B

B

A

A

SIZE B	SCALE:	DRAWING NUMBER: 123908	REV: B1
			SHEET NUMBER: 2 OF 2

8

7

6

5

4

3

2

1

SINGLE LEVEL MFG BILL OF MATERIAL

FIND	QTY	PART NO	REV	DESCRIPTION	REFERENCE DESIGNATOR
1	1 EA	123907-14569		BELT, TIMING, 1/5 PITCH, 145 GROOVES, 1	
2	1 EA	123907-17269	A1	BELT, TIMING, 1/5 PITCH, 172 GROOVES, 1	
3	1 EA	116430-17525		BELT, TIMING, .080 PITCH, 175 GROOVES,	

				
BELT KIT, XX97B / XX00B				
PROD FAMILY COMMON	EFF. DATE 30-Jun-08	SHT 1 OF 1	DRAWING NUMBER 128545-1	REV A

SINGLE LEVEL MFG BILL OF MATERIAL

FIND	QTY	PART NO	REV	DESCRIPTION	REFERENCE DESIGNATOR
1	1 EA	127903-1	A	EL MOTOR ASS'Y, WITH BRAKE, 9797B-76	
2	1 EA	127901-1	X4	MOTOR ASS'Y, CROSS LEVEL, 9797B-76	
3	1 EA	125081-2	A2	AZ TRAIN MOTOR ASS'Y, XX07, LH TERMI	
4	1 EA	122532-1	D2	SHIELDED LEVEL CAGE MOTOR ASS'Y, .0	
5	1 EA	121880-1	A1	MOTOR ASS'Y, POLANG, (PRI-FOCUS)	
6	1 EA	116463	D1	GEAR, SPUR, 12T	
7	1 EA	114590-144		SCREW, SOCKET SET-CUP, 6-32 x 1/4, S.S.	
8	1 EA	117319-10	C2	LOCTITE, 271 THREADLOCKER, 0.5ML	

				
MOTOR KIT, XX97B / XX00B				
PROD FAMILY COMMON	EFF. DATE 30-Jun-08	SHT 1 OF 1	DRAWING NUMBER 128546-1	REV A

SINGLE LEVEL MFG BILL OF MATERIAL

FIND	QTY	PART NO	REV	DESCRIPTION	REFERENCE DESIGNATOR
1	1 EA	127513-1	A	PCU ASS'Y, XX97B, STD	
2	1 EA	117168-1	M	MODEM ASS'Y, PEDESTAL, 3 CH, 75 OHM	
3	1 EA	117168-2	M	MODEM ASS'Y, BASE, 3 CH, 75 OHM	
4	1 EA	122208-1	J	LEVEL CAGE ASS'Y, 90 DEG EL RANGE, IN	
5	1 EA	116024-3	J2	SHIELDED POLANG RELAY ASS'Y	
6	1 EA	127602-2	X3	SERVO AMPLIFIER INSTALL, 5 AMP	
7	1 EA	121966-6	D1	GPS ANTENNA, RETERMINATED, 32.0 L	
8	1 IN	124077-4	A1	TAPE, 3M VHB #4952, SYNTHETIC ADHESI	
9	1 EA	115767	F3	POT ASS'Y (MECH.), POLANG	
10	1 EA	127946-1	X2	HYBRID POWER RING ASS'Y, 4 CH	
11	1 EA	128204-1	X3	RF SWITCH ASSEMBLY	
12	1 EA	114540	B1	LNB, C-BAND	
13	1 EA	122386	D	FILTERED LNB ASS'Y, QUAD, XX98, XX04	
14	1 EA	128545-1	A	BELT KIT, XX97B / XX00B	
15	1 EA	114789-810		TRANSPORT CONTAINER	

				
SPARE PARTS KIT, XX97B / XX00B, COMPREHENSIVE				
PROD FAMILY COMMON	EFF. DATE 30-Jun-08	SHT 1 OF 1	DRAWING NUMBER 128547-1	REV A

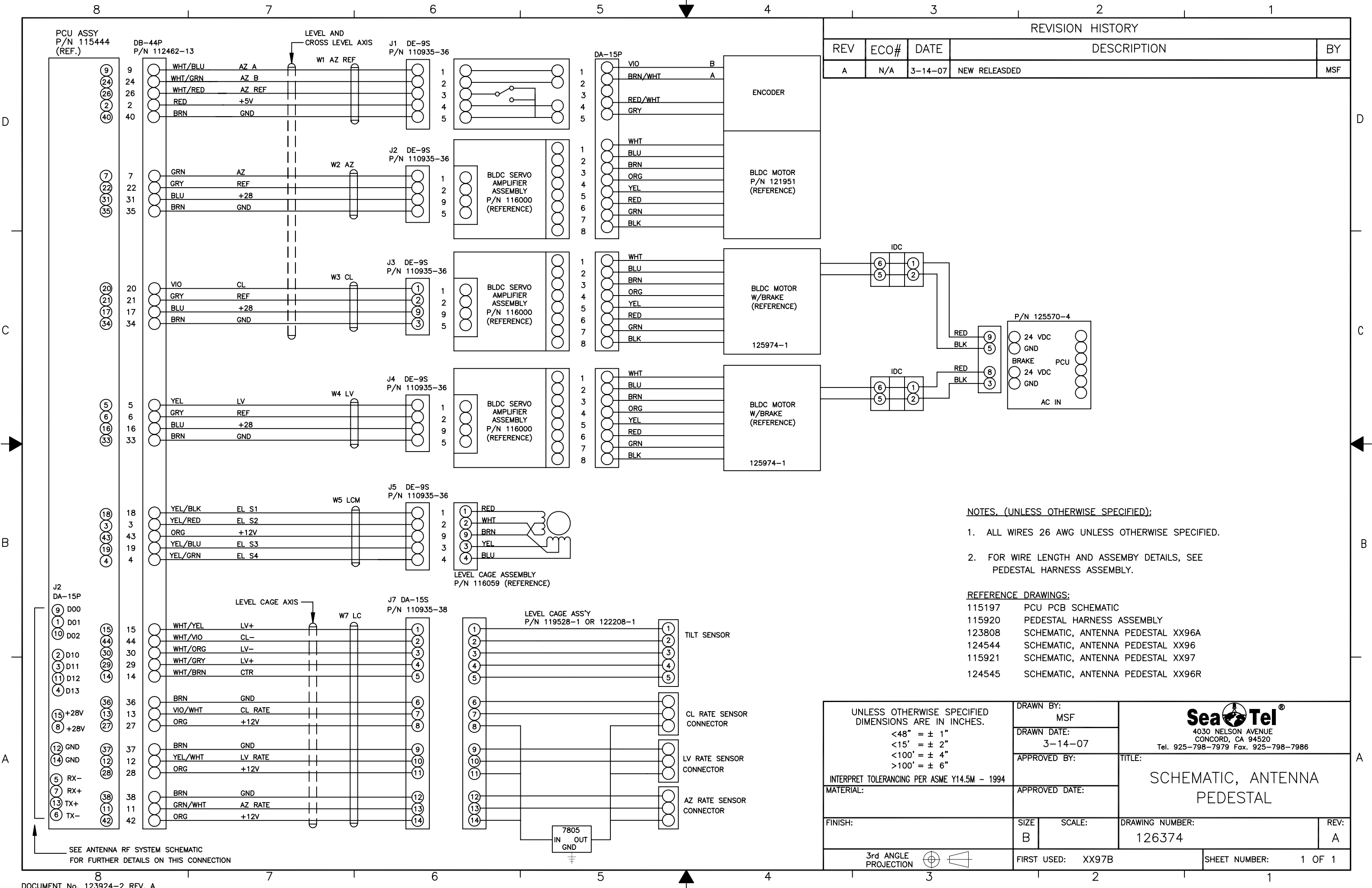

SINGLE LEVEL MFG BILL OF MATERIAL

FIND	QTY	PART NO	REV	DESCRIPTION	REFERENCE DESIGNATOR
1	1 EA	116880	F	PANEL MACHINING, RACK, BASE MUX	
2	1 EA	117168-2	M	MODEM ASS'Y, BASE, 3 CH, 75 OHM	
3	1 EA	118429	O	BRACKET, CONNECTOR	
4	1 EA	128001-8BLU		CABLE ASS'Y, RG-179 COAX, F(M) TO SMA	
5	4 EA	114178	O	ADAPTER, F(F)-F(F) (BULLET), 1.0 IN L	
50	6 EA	114588-144		SCREW, PAN HD, PHIL, 6-32 x 1/4, S.S.	
51	6 EA	114580-007		WASHER, FLAT, #6, S.S.	
60	4 EA	119967	A	NUT, HEX, PANEL, 3/8-32	
61	4 EA	119952-031	A1	WASHER, STAR, INTERNAL TOOTH, 3/8, S.	

				
BASE MODEM RACK PANEL ASS'Y, 4CH TVRO				
PROD FAMILY COMMON	EFF. DATE 01-Jul-08	SHT 1 OF 1	DRAWING NUMBER 128303-1	REV A

8 7 6 5 4 3 2 1

REVISION HISTORY				
REV	ECO#	DATE	DESCRIPTION	BY
A	N/A	6-30-08	RELEASED TO PRODUCTION; WAS REV X2	SMS

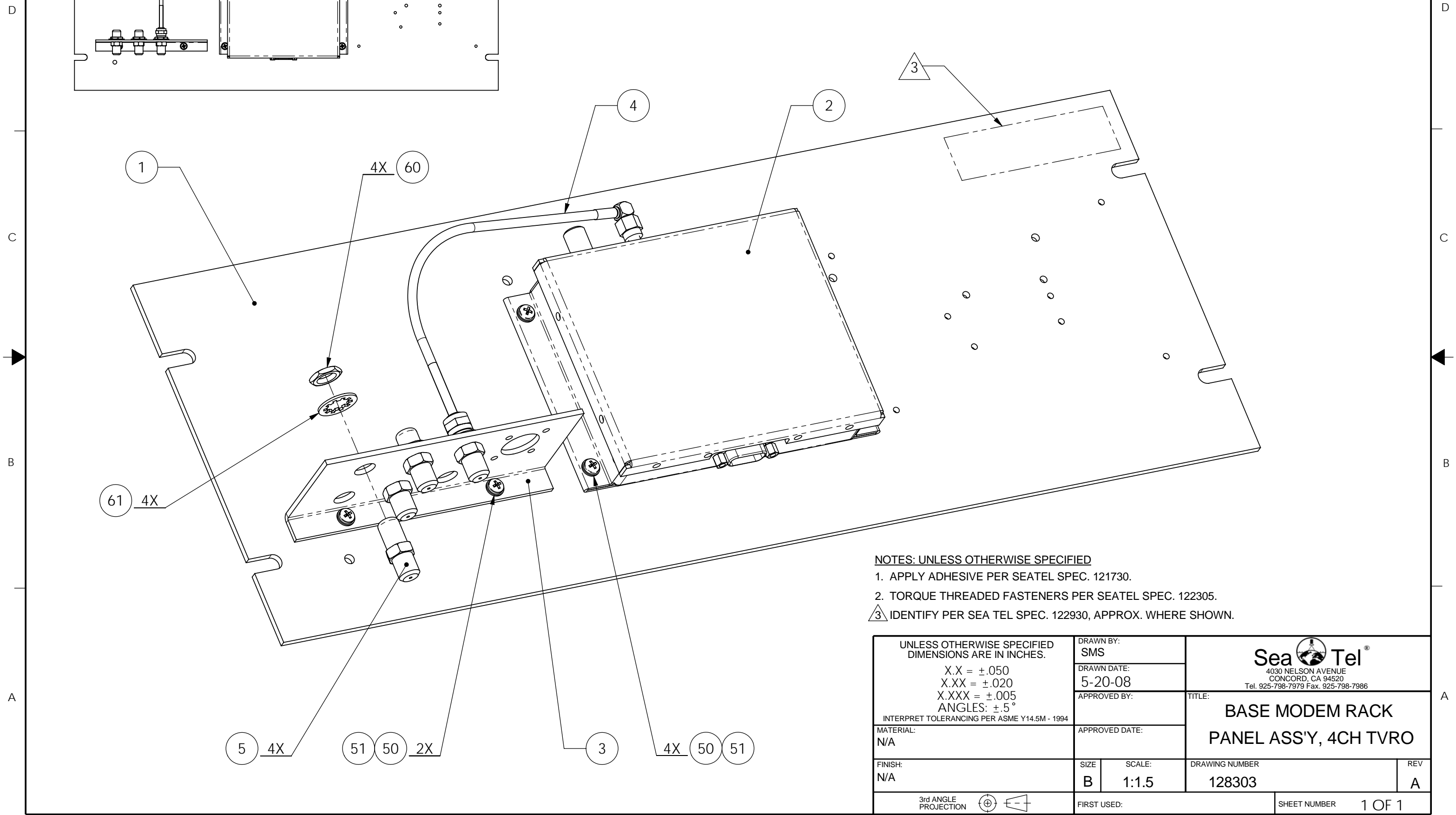
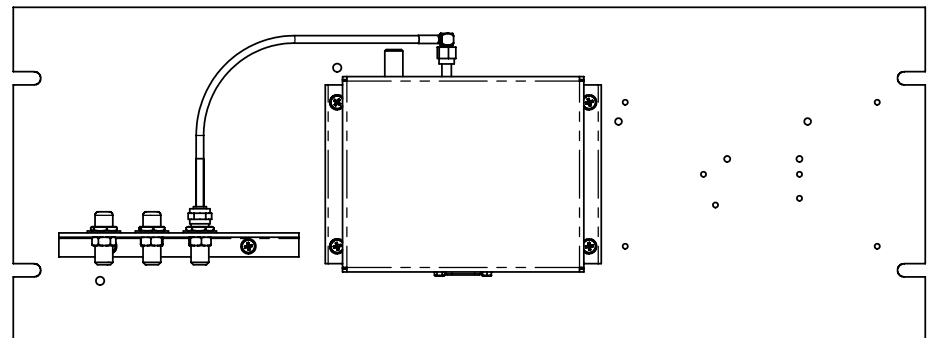

- NOTES: UNLESS OTHERWISE SPECIFIED**
1. APPLY ADHESIVE PER SEATEL SPEC. 121730.
 2. TORQUE THREADED FASTENERS PER SEATEL SPEC. 122305.
 3. IDENTIFY PER SEA TEL SPEC. 122930, APPROX. WHERE SHOWN.

UNLESS OTHERWISE SPECIFIED DIMENSIONS ARE IN INCHES. X.X = ±.050 X.XX = ±.020 X.XXX = ±.005 ANGLES: ±.5° INTERPRET TOLERANCING PER ASME Y14.5M - 1994	DRAWN BY: SMS		 4030 NELSON AVENUE CONCORD, CA 94520 Tel. 925-798-7979 Fax. 925-798-7986
	DRAWN DATE: 5-20-08		
MATERIAL: N/A	APPROVED BY:		TITLE: BASE MODEM RACK PANEL ASS'Y, 4CH TVRO
FINISH: N/A	APPROVED DATE:	SIZE: B	SCALE: 1:1.5
FIRST USED:		DRAWING NUMBER: 128303	REV: A
3rd ANGLE PROJECTION		SHEET NUMBER 1 OF 1	

8 7 6 5 4 3 2 1