

**INSTALLATION AND OPERATION MANUAL
FOR SEA TEL MODEL
9707D-70 C-BAND TX/RX ANTENNA**

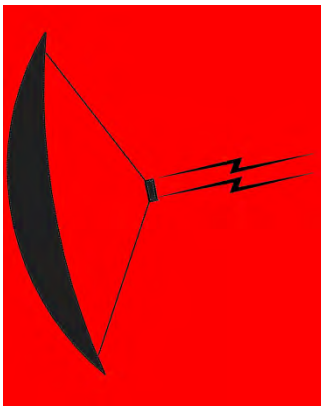

WARNING: RF RADIATION HAZARD

This stabilized antenna system is designed to be used with transmit/receive equipment manufactured by others. Refer to the documentation supplied by the manufacturer which will describe potential hazards, including exposure to RF radiation, associated with the improper use of the transmit/receive equipment. Note that the transmit/receive equipment will operate independently of the stabilized antenna system. Prior to work on the stabilized antenna system, the power to the transmit/receive system must be locked out and tagged.

When the transmit/receive system is in operation, no one should be allowed **anywhere within the radiated beam** being emitted from the reflector.

The ultimate responsibility for safety rests with the facility operator and the individuals who work on the system.

Sea Tel, Inc.
4030 Nelson Avenue
Concord, CA 94520
Tel: (925) 798-7979
Fax: (925) 798-7986
Email: seatel@cobham.com
Web: : www.cobham.com/seatel

Sea Tel
COBHAM

Sea Tel Europe
Unit 1, Orion Industrial Centre
Wide Lane, Swaythling
Southampton, UK S0 18 2HJ
Tel: 44 (0)23 80 671155
Fax: 44 (0)23 80 671166
Email: seatel@cobham.com
Web: www.cobham.com/seatel

Sea Tel Inc doing business as Cobham SATCOM

December 15, 2009

Document. No. 125266 Revision E



Sea Tel is an ISO 9001:2000 registered company. Certificate Number 19.2867 was issued August 12, 2005. Sea Tel was originally registered on November 09, 1998.



Sea Tel Marine Stabilized Antenna systems are manufactured in the United States of America.



These commodities, technology or software were exported from the United States in accordance with the Export Administration Regulations. Diversion contrary to U.S. law is prohibited.



The Series 97 Family of Marine Stabilized Antenna Pedestals with DAC-97 Antenna Control Unit complied with the requirements of European Norms and European Standards EN 60945 (1997) and prETS 300 339 (1998-03) on July 20, 1999. Sea Tel document number 119360 European Union Declaration of Conformity for Marine Navigational Equipment is available on request.

Copyright Notice

All Rights Reserved. The information contained in this document is proprietary to Sea Tel, Inc.. This document may not be reproduced or distributed in any form without the consent of Sea Tel, Inc. The information in this document is subject to change without notice.

Copyright © 2008 Sea Tel, Inc.



Marine Stabilized Antenna Systems
European Union Declaration of Conformity
Marine Navigational Equipment

The EU Directives Covered by this Declaration:

European Norms and European Standards EN 60945 (1997) and prETS 300 339 (1998-03).

The Product Covered by this Declaration:

Series 97 Family of Marine Stabilized Antenna Pedestals with DAC-97 Antenna Control Unit

The Basis on which Conformity is being Declared:

The product identified above complies with the requirements of the above EU Directives by meeting the following standards on July 20, 1999:

*** EN 60945 (1997) "Marine Navigational Equipment - General Requirements – Methods of Testing and Required Test Results":**

- Conducted Emissions (Clause 9.1 & 9.2)
- Radiated Emissions (Clause 9.1 & 9.3)
- Conducted Low Frequency Interference (Clause 10.1 & 10.2)
- Conducted Radiofrequency Interference (Clause 10.1 & 10.3)
- Radiated Radiofrequencies (Clause 10.1 & 10.4)
- Fast Transients on Signal/Control Lines (Clause 10.1 & 10.5)
- Surges on AC Power Lines (Clause 10.1 & 10.6)
- Power Supply Short-Term Variation (Clause 10.1 & 10.7)
- Power Supply Failure (Clause 10.1 & 10.8)
- Electrostatic Discharge (Clause 10.1 & 10.9)
- Compass Safe Distance (Clause 11.2, Measurement Only)
- Electromagnetic RF Radiation (Clause 12.2)

*** prETS 300 339 (1998-03) Electromagnetic compatibility and Radio spectrum Matters (ERM); General ElectroMagnetic Compatibility (EMC) for Radio Communications Equipment.**

- Antenna Port Spurious Emissions (Clause 8.4)
- RF Radiated Field Immunity (Clause 9.3)
- Voltage Dips & Short Interruptions (Clause 9.4)
- RF Common Mode Immunity (Clause 9.4, 9.5 & 9.6)

The technical documentation required to demonstrate that this product meets the requirements of the EMC Directive has been compiled by the signatory below and is available for inspection by the relevant enforcement authorities. The CE mark was first applied in 1999.

Authority: Mr. J. Patrick Matthews
President

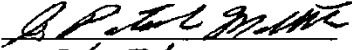
Signature: 
Date: 7/25/02

Attention

The attention of the specifier, purchaser, installer or user is drawn to special measures and limitations to use which must be observed when the product is taken into service to maintain compliance with the above directives. Details of these special measures and limitations are in the product manual.

RF Transmit and Receive equipment components (Radio Packages, Drivers, HPAs and LNCs) or TVRO LNBs which are mounted on the Marine Stabilized Antenna Pedestal must be CE marked separately by the manufacturer of those components.



Sea Tel, Inc.
4030 Nelson Ave.
Concord, CA. 94520
Phone: (925) 798-7979
Fax: (925) 798-7986



Doc 119360-A

Revision History

REV	ECO#	Date	Description	By
A	N/A	June 26, 2006	Initial Production Release	MDN
B	5499	September 19, 2007	Change ACU to DAC-2202. Update text and drawings.	MDN
C	6226	June 19, 2008	Update text and drawings to reflect ECO 6226 changes	ECM
D	N/A	March 4, 2009	Update font, logo, text and drawings	MDN
E	N/A	December 15, 2009	Updated Text, Graphics, and drawings to reflect current build configuration and GSR2 features	ECM

Table of Contents

1. INTRODUCTION	1-1
1.1. GENERAL SYSTEM DESCRIPTION	1-1
1.2. PURPOSE	1-1
1.3. SYSTEM COMPONENTS	1-1
1.4. GENERAL SCOPE OF THIS MANUAL	1-2
1.5. QUICK OVERVIEW OF CONTENTS	1-2
2. OPERATION	2-1
2.1. SYSTEM POWER-UP	2-1
2.2. ANTENNA INITIALIZATION	2-1
2.3. ANTENNA STABILIZATION	2-1
2.4. STABILIZED PEDESTAL ASSEMBLY OPERATION	2-2
2.5. TRACKING OPERATION	2-2
2.6. ANTENNA POLARIZATION OPERATION	2-2
2.7. LOW NOISE BLOCK CONVERTER OPERATION	2-2
2.8. RF EQUIPMENT	2-2
2.9. RADOME ASSEMBLY OPERATION	2-2
3. BASIC SYSTEM INFORMATION	3-1
3.1. SATELLITE BASICS	3-1
3.1.1. C-Band Receive Frequency (3.7-4.2GHz)	3-1
3.1.2. Blockage	3-1
3.1.3. Rain Fade	3-1
3.1.4. Signal level	3-1
3.1.5. Satellite Footprints	3-2
3.1.6. Satellite Circular Polarization	3-2
3.2. ANTENNA BASICS	3-2
3.2.1. Unlimited Azimuth	3-2
3.2.2. Elevation	3-2
3.2.3. Antenna polarization	3-2
3.2.4. Stabilization	3-2
3.2.5. Search Pattern	3-2
3.2.6. Tracking Receiver – Single Channel Per Carrier Receiver	3-3
3.2.7. Tracking	3-3
3.3. COMPONENTS OF THE SYSTEM CONFIGURATION	3-4
3.3.1. Antenna ADE Assembly	3-5
3.3.2. Antenna Control Unit	3-5
3.3.3. Above Decks AC Power Supply	3-5
3.4. POSITIVE SATELLITE ID	3-6
3.5. OPEN ANTENNA-MODEM INTERFACE PROTOCOL (OPENAMIP™) SPECIFICATION:	3-6
3.5.1. Overview:	3-6
3.5.2. Interface requirements:	3-6
3.5.3. Utilized OpenAMIP Commands:	3-7
4. INSTALLATION	4-1
4.1. GENERAL CAUTIONS & WARNINGS	4-1
4.2. SITE SURVEY	4-2
4.3. PREPARING FOR THE INSTALLATION	4-2
4.3.1. Unpack Shipping Crates	4-2
4.3.2. Inspect / Inventory	4-2
4.3.3. Prepare ADE Mounting Location	4-2

Table of Contents

4.3.4.	<i>Preparing BDE Location</i>	4-3
4.3.5.	<i>Installing The System Cables</i>	4-3
4.4.	ASSEMBLING THE ADE	4-3
4.4.1.	<i>144" Radome, Baseframe and Antenna Pedestal System Assembly</i>	4-3
4.4.2.	<i>Preparing the ADE for Lift</i>	4-4
4.5.	INSTALLING THE ADE	4-4
4.5.1.	<i>Hoist</i>	4-4
4.5.2.	<i>Install Antenna/Radome/Baseframe</i>	4-5
4.5.3.	<i>Cooling Unit Assembly - TX SYSTEMS ONLY</i>	4-5
4.6.	INSTALL BDE EQUIPMENT	4-5
4.6.1.	<i>ACU & TMS</i>	4-5
4.6.2.	<i>Other BDE Equipment</i>	4-5
4.7.	CABLE TERMINATIONS	4-5
4.7.1.	<i>At The Radome</i>	4-5
4.7.2.	<i>ACU & TMS</i>	4-5
4.7.3.	<i>Other BDE Equipment</i>	4-5
4.8.	FINAL ASSEMBLY	4-5
4.8.1.	<i>Mount RF Equipment (TXRX Only)</i>	4-5
4.8.2.	<i>Remove Stow Braces/Restraints</i>	4-6
4.8.3.	<i>Verify all assembly and Wiring connections</i>	4-6
4.8.4.	<i>Balance Antenna Pedestal</i>	4-6
4.9.	POWER-UP THE ADE	4-6
4.9.1.	<i>Initialization</i>	4-6
4.9.2.	<i>Home Flag Position</i>	4-6
4.9.3.	<i>BDE</i>	4-6
4.10.	SETUP	4-6
5.	SETUP	5-1
5.1.	OPERATOR SETTINGS	5-1
5.2.	OPTIMIZING TARGETING (AUTO TRIM)	5-1
5.3.	OPTIMIZING TARGETING (MANUALLY)	5-1
5.4.	OPTIMIZING AUTO-POLARIZATION TX/RX	5-1
5.5.	CALIBRATING RELATIVE ANTENNA POSITION (HOME FLAG OFFSET)	5-2
5.5.1.	<i>To Calculate HFO:</i>	5-2
5.5.2.	<i>To Enter the HFO value:</i>	5-4
5.6.	RADIATION HAZARD AND BLOCKAGE MAPPING (AZ LIMIT PARAMETERS)	5-4
5.7.	TX POLARITY SETUP	5-4
5.1.	SAT SKEW SETTING	5-2
5.2.	POLARITY ANGLE (POLANG) PARAMETERS	5-2
5.3.	DEFAULT SETUP PARAMETERS	5-3
6.	FUNCTIONAL TESTING	6-1
6.1.	ACU / ANTENNA SYSTEM CHECK	6-1
6.2.	ACU / ANTENNA SYSTEM CHECK	6-1
6.3.	LATITUDE/LONGITUDE AUTO-UPDATE CHECK	6-1
6.4.	AZIMUTH & ELEVATION DRIVE	6-1
6.5.	FOUR QUADRANT TRACKING TEST	6-1
7.	MAINTENANCE AND TROUBLESHOOTING	7-1
7.1.	WARRANTY INFORMATION	7-1
7.2.	RECOMMENDED PREVENTIVE MAINTENANCE	7-1

Table of Contents

7.2.1.	Check ACU Parameters	7-2
7.2.2.	Latitude/Longitude Auto-Update check	7-2
7.2.3.	Heading Following.....	7-2
7.2.4.	Azimuth & Elevation Drive.....	7-2
7.2.5.	Test Tracking	7-2
7.2.6.	Visual Inspection - Radome & Pedestal	7-3
7.2.7.	Mechanical Checks	7-3
7.2.8.	Check Balance.....	7-3
7.2.9.	Observe Antenna Initialization.....	7-3
7.3.	TROUBLESHOOTING.....	7-3
7.3.1.	Theory Of Stabilization Operation.....	7-3
7.3.2.	Antenna Initialization (Series 97B & Series 00).....	7-4
7.3.3.	Troubleshooting using DacRemP	7-4
7.3.4.	Antenna Loop Error Monitoring.....	7-5
7.3.5.	Reference Sensor Monitoring	7-7
7.3.6.	Open Loop Rate Sensor Monitoring	7-8
7.3.7.	Open Loop Motor Test.....	7-9
7.3.8.	To Disable/Enable DishScan.....	7-9
7.3.9.	Satellite Reference Mode.....	7-10
7.3.10.	To Read/Decode an ACU Error Code 0008 (Pedestal Function Error):	7-10
7.3.11.	Remote GPS LAT/LON Position:.....	7-12
7.4.	MAINTENANCE.....	7-14
7.4.1.	Balancing the Antenna	7-14
7.4.2.	Polang Alignment	7-14
7.4.3.	To Adjust Tilt:.....	7-15
7.4.4.	To Reset/Reinitialize the Antenna:.....	7-16
7.5.	PEDESTAL CONTROL UNIT CONFIGURATION - 9707.....	7-17
7.5.1.	To configure the PCU;.....	7-17
7.5.2.	Balancing the Antenna	7-17
8.	9707D-70 TECHNICAL SPECIFICATIONS.....	8-1
8.1.	ANTENNA REFLECTOR.....	8-1
8.2.	FEED ASSEMBLIES.....	8-1
8.2.1.	C-Band TXRX Feed Assembly.....	8-1
8.3.	RF EQUIPMENT	8-1
8.4.	STABILIZED ANTENNA PEDESTAL ASSEMBLY	8-2
8.5.	PEDESTAL CONTROL UNIT (PCU).....	8-2
8.6.	UNLIMITED AZIMUTH MODEMS (3 CHANNEL) L-BAND IF	8-3
8.7.	144" RADOME ASSEMBLY	8-3
8.8.	ENVIRONMENTAL CONDITIONS (ADE).....	8-3
8.9.	TXRX SYSTEM CABLES	8-4
8.9.1.	Antenna Control Cable (Provided from ACU-MUX).....	8-4
8.9.2.	Antenna Transmit & Receive IF Coax Cables (Customer Furnished)	8-4
8.9.3.	Multi-conductor Cables (Customer Furnished)	8-4
8.9.4.	AC Power Cable Above Decks (Customer Furnished).....	8-4
8.9.5.	Gyro Compass Interface Cable (Customer Furnished).....	8-4
9.	DRAWINGS	9-5
9.1.	9707D-70 MODEL SPECIFIC DRAWINGS	9-5
9.2.	SERIES 07 GENERAL DRAWINGS	9-5

Table of Contents

This Page Intentionally Left Blank

1. Introduction



WARNING: *RF Radiation Hazard - This stabilized antenna system is designed to be used with transmit/receive equipment manufactured by others. Refer to the documentation supplied by the manufacturer which will describe potential hazards, including exposure to RF radiation, associated with the improper use of the transmit/receive equipment. Note that the transmit/receive equipment will operate independently of the stabilized antenna system.*

The ultimate responsibility for safety rests with the facility operator and the individuals who work on the system.

1.1. General System Description

Your Series 07 system is a fully stabilized antenna that has been designed and manufactured so as to be inherently reliable, easy to maintain, and simple to operate. Except for start-ups, or when changing to operate with different transponders or satellites, the equipment essentially permits unattended operation.

1.2. Purpose

This shipboard Transmit-Receive (TXRX) system provides you with two-way satellite voice/data communications while underway on an ocean-going vessel. This can be used to provide a wide variety of telephone, fax and data applications. Your Series 07 Antenna system can transmit to and receive from any desired satellite which has adequate signal coverage in your current geographic area. Your antenna is fitted with appropriate Transmit & Receive RF Equipment and appropriate Feed to allow you to operate in circular polarization mode at C-Band frequencies. This input will be distributed to your satellite modem and then to all of your other below decks equipment.

1.3. System Components

The 9707 TXRX system consists of two major groups of equipment; an above-decks group and a below-decks group. Each group is comprised of, but is not limited to, the items listed below. All equipment comprising the Above Decks is incorporated inside the radome assembly and is integrated into a single operational entity. For inputs, this system requires only an unobstructed line-of-sight view to the satellite, Gyro Compass input and AC electrical power.

For more information about these components, refer to the Basic System Information section of this manual.

A. Above-Decks Equipment (ADE) Group

1. Stabilized antenna pedestal
2. Antenna Reflector
3. Feed Assembly with LNB(s)
4. C-Band Block Up Converter (BUC)
5. Radome Assembly

B. Below-Decks Equipment Group

6. Antenna Control Unit
7. Splitter with desired number of outputs (one output to the ACU and one output to the Satellite Modem are required).
8. Satellite Modem and other below decks equipment required for the desired communications purposes.
9. Spectrum Analyzer (Optional)
10. Control, RF and Video cables

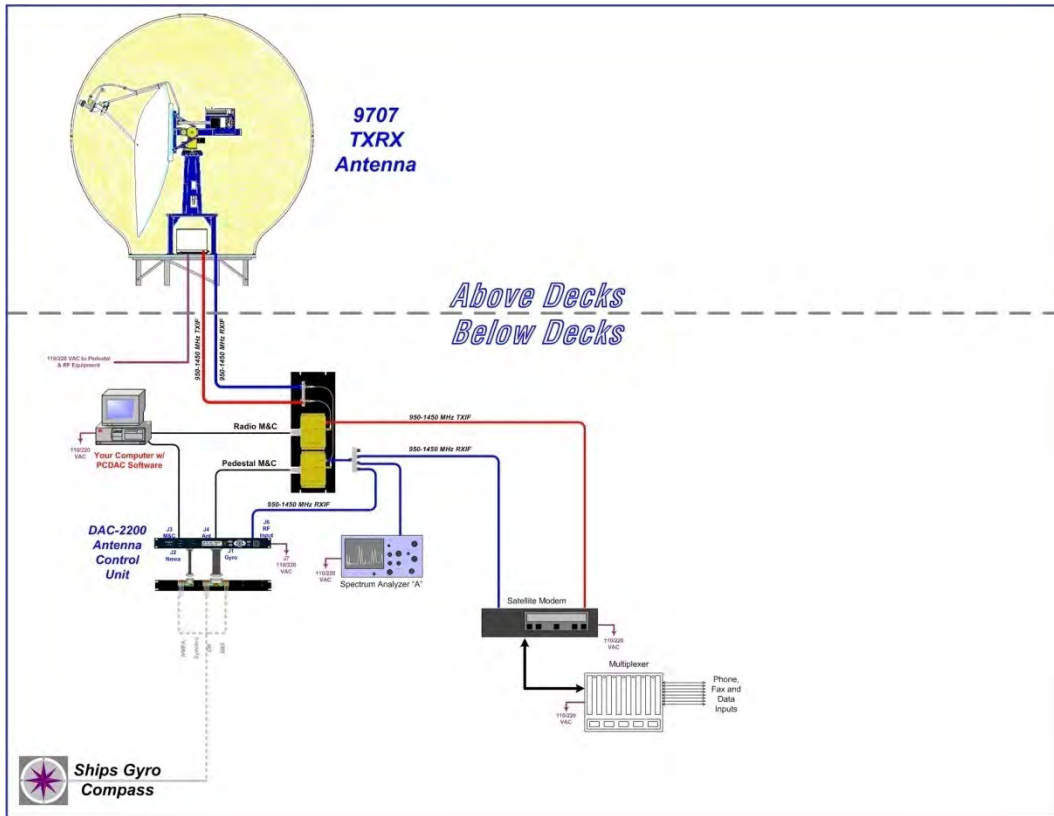

Figure 1-1 9707 TXRX Simplified Block Diagram



1.4. General scope of this manual

This manual describes the Sea Tel Series 07 Antenna (also called the Above Decks Equipment), its' operation and installation. Refer to the manual provided with your Antenna Control Unit for its' installation and operating instructions.

1.5. Quick Overview of contents

The information in this manual is organized into chapters. Operation, basic system information, installation, setup, functional testing, maintenance, specifications and drawings relating to this Antenna are all contained in this manual

2. Operation

	<p>WARNING: RF Radiation Hazard - This stabilized antenna system is designed to be used with transmit/receive equipment manufactured by others. Refer to the documentation supplied by the manufacturer which will describe potential hazards, including exposure to RF radiation, associated with the improper use of the transmit/receive equipment. Note that the transmit/receive equipment will operate independently of the stabilized antenna system.</p>
	<p>WARNING: RF Radiation Hazard - When the transmit/receive system is in operation, no one should be allowed anywhere within the radiated beam being emitted from the reflector.</p>

The ultimate responsibility for safety rests with the facility operator and the individuals who work on the system.

The ultimate responsibility for safety rests with the facility operator and the individuals who work on the system.

2.1. System Power-up

Turn the Power switch on the louvered panel of the antenna pedestal ON. This will energize the antenna pedestal and the associated RF equipment.

Turn the Power switch on rear panel of the Antenna Control Unit (ACU) ON.

2.2. Antenna Initialization

A functional operation check can be made on the antenna stabilization system by observing its behavior during the 4 phases of initialization.

Turn the pedestal power supply ON. The PCU will initialize the stabilized portion of the mass to be level with the horizon and at a prescribed Azimuth and Elevation angles. The antenna will go through the specific sequence of steps (listed below) to initialize the antenna. These phases initialize the level cage, elevation, cross-level and azimuth to predetermined starting positions.

Initialization is completed in the following phases, each phase must complete properly for the antenna to operate properly (post-initialization).

1. Level Cage is driven CCW, issuing extra steps to assure that the cage is all the way to the mechanical stop. Then the Level cage will be driven exactly 45.0 degrees CW.
2. Elevation axis activates - Input from the LV axis of the tilt sensor is used to drive the Elevation of the equipment frame to bring the tilt sensor LV axis to level (this results in the dish being at an elevation angle of 45.0 degrees).
3. Cross-Level axis activates - Input from the CL axis of the tilt sensor is used to drive Cross-Level of the equipment frame to bring the cross-level axis of the tilt sensor to level (this results in the tilt of the Cross-Level Beam being level).
4. Azimuth axis activates - Antenna drives in azimuth until the "Home Flag" signal is produced. This signal is produced by a Home Switch hitting a cam or by a Hall Effect sensor in close proximity to a Magnet.

This completes the phases of initialization. At this time the antenna elevation should 45.0 degrees and Relative azimuth should be at be at home flag (home switch engaged on the home flag cam).

If any of these steps fail, or the Antenna Control Unit reports model number as "xx97" re-configure the PCU as described in section the Setup section of this manual. If initialization still fails, refer to the troubleshooting section of this manual.

2.3. Antenna Stabilization

After initialization has completed, real-time stabilization of the antenna is an automatic function of the PCU.

2.4. Stabilized Pedestal Assembly Operation

Operation of the stabilized antenna Pedestal Control Unit (PCU) is accomplished remotely by the Antenna Control Unit (ACU). Refer to the Operation section of the Antenna Control Unit manual for more specific operation details. There are no other operating instructions applicable to the pedestal assembly by itself.

2.5. Tracking Operation

Tracking optimizes the antenna pointing, in very fine step increments, to maximize the level of the satellite signal being received. The mode of tracking used in this antenna is a variation of Conical Scanning called DishScan.

DishScan continuously drives the antenna in a very small circular pattern at 60 RPM. The ACU evaluates the received signal throughout each rotation to determine where the strongest signal level is (Up, Right, Down or Left) and issues the appropriate Azimuth and/or Elevation steps to the antenna, as needed.

You cannot control tracking from the pedestal itself. Refer to the ACU manual for tracking operation information.

2.6. Antenna Polarization Operation

Your Scalar Plate assembly is equipped with a polarization motor and potentiometer feedback that are controlled from the Antenna Control Unit. This allows you to have a Linear, or a Circular, feed assembly installed on your antenna.

When you have a Circular feed installed, polarization adjustment, is NOT required. You should set the POL TYPE parameter in your ACU to 0000.

When you have a Linear feed installed, polarization may be operated manually from the ACU but Auto-Polarization mode is the default polarization mode of operation from the ACU and is strongly recommended (set POL TYPE parameter in your ACU to 0072). Refer to the Antenna Control Unit manual for more operation information.

2.7. Low Noise Block Converter Operation

There are no operating instructions or controls applicable to the LNB. This unit is energized by the ACU (or by the pedestal modem on some systems).

2.8. RF Equipment

The RF Equipment is not operated or controlled by the antenna pedestal or Antenna Control Unit. Refer to the vendor supplied manuals for the RF Equipment provided with your system.

2.9. Radome Assembly Operation

When operating the system it is necessary that the radome access hatch (and/or side door) be closed and secured in place at all times. This prevents rain, salt water and wind from entering the radome. Water and excessive condensation promote rust & corrosion of the antenna pedestal. Wind gusts will disturb the antenna pointing.

There are no other operating instructions applicable to the radome assembly by itself.

3. Basic System Information

This section provides you with some additional information about the satellites you will be using, basics of your Series 07 antenna system and some of the other equipment within your system configuration.

3.1. **Satellite Basics**

The satellites are in orbit at an altitude of 22,754 miles and are positioned directly above the equator. Their orbital velocity matches the Earth's rotational speed, therefore, each appears to remain at a fixed position in the sky (as viewed from your location).

Your antenna can be used with any of the satellites in this orbit that have a strong enough receive signal level. Your antenna is capable of being fitted with a Linear or Circular feed assembly. The feed may be designed to operate at C-Band frequencies, Ku-Band frequencies or be capable of operation in both bands. With the correct feed assembly you will be able to receive the linear or circular signal at the specific frequency range of the desired satellite.

3.1.1. **C-Band Receive Frequency (3.7-4.2GHz)**

At these frequencies the signal from the satellite travels only in a straight line and is affected by weather changes in the atmosphere. There are several conditions that can cause a temporary loss of satellite signal, even within an area where the signal level is known to be adequate. The most common of these *normal* temporary losses are **blockage** and **rain fade**. They will interrupt services only as long as the cause of the loss persists.

3.1.2. **Blockage**

Blockage is loss due to an object in the path of the signal from the satellite to the dish. If an object that is large and dense is positioned in the path of the signal from the satellite, it will prevent sufficient signal from arriving at the dish. The signal can not bend around, or penetrate through, these objects and the reception will be degraded or completely interrupted. The dish is actively driven to remain pointed at the satellite (toward the equator) so, as the ship turns a mast or raised structure of your ship may become positioned between the satellite and the dish. Blockage may also be caused anything standing near the radome, tall mountains, buildings, bridges, cranes or other larger ships near your ship. Moving or rotating the ship to position the antenna where it has an unobstructed view to the desired satellite will restore the antennas' ability to receive the satellite signal.

3.1.3. **Rain Fade**

Atmospheric conditions that may cause sufficient loss of signal level include rain, snow, heavy fog and some solar activities (sun spot and flare activity). The most common of these is referred to as "rain fade". Rain drops in the atmosphere reduce the signal from the satellite. The heavier the rain the higher the amount of signal loss. When the amount of loss is high enough, the antenna will not be able to stay locked onto the satellite signal. When the amount of rain has decreased sufficiently, the antenna will re-acquire the satellite signal. In a strong signal area, rain fall of about four inches per hour will cause complete loss of signal. In weaker signal areas the effects would be more pronounced.

3.1.4. **Signal level**

The level of the receive signal is dependant upon how powerful the transmission is, how wide the signal beam is, and what the coverage area is. Focusing the signal into a narrower beam concentrates its energy over a smaller geographic area, thereby increasing the signal level throughout that area of coverage. This makes it possible for you to use a smaller antenna size to receive that satellite signal. The antenna system must be geographically located in an area where the signal level from the satellite meets (or exceeds) the minimum satellite signal level required for your size of antenna (refer to the Specifications section of this manual) to provide suitable reception. This limits the number of satellites that can be used and the geographic areas where the ship can travel where the signal level is expected to be strong enough to continue providing uninterrupted reception. When traveling outside this minimum signal coverage area, it is normal for the system to experience an interruption in its ability to provide the desired satellite services until entering (or re-entering) an area of adequate signal level.

3.1.5. Satellite Footprints

The focused beam(s) from the satellites are normally aimed at the major land masses where there are large population centers. Footprint charts graphically display the signal level expected to be received in different geographic locations within the area of coverage. The signal will always be strongest in the center of the coverage area and weaker out toward the outer edges of the pattern. The coverage areas are intended to be a guide to reception, however, the actual coverage area and signal level and vary. Also the signal strength is affected by weather.

3.1.6. Satellite Circular Polarization

When the satellite you are using is transmitting **circular** polarized satellite transmissions, you will not need to adjust the “polarization” of your antenna.

3.2. Antenna Basics

The following information is provided to explain some of the basic functions of the antenna:

3.2.1. Unlimited Azimuth

Azimuth rotation of the antenna is unlimited (no mechanical stops). Azimuth drive, provided by the azimuth motor, is required during stabilization, searching and tracking operations of the antenna. When the ship turns, azimuth is driven in the opposite direction to remain pointed at the satellite. The actual azimuth pointing angle to the satellite is determined by your latitude & longitude and the longitude of the satellite. It is important to know that the antenna should be pointed (generally) toward the equator.

The azimuth angle to the satellite would be 180 degrees true (relative to true north) if the satellite is on the same longitude that you are on. If the satellite is east, or west, of your longitude the azimuth will be less than, or greater than 180 degrees respectively.

When checking for blockage you can visually look over the antenna radome toward the equator to see if any objects are in that sighted area. If you are not able to find any satellites it may also be useful to remove the radome hatch to visually see if the dish is aimed the correct direction (towards the equator).

3.2.2. Elevation

In normal operation the elevation of the antenna will be between 00.0 (horizon) and 90.0 (zenith). The antenna can physically be rotated in elevation below horizon and beyond zenith to allow for ship motion. Elevation drive, provided by the elevation motor, is required during stabilization, searching and tracking operations of the antenna. The actual elevation pointing angle to the satellite is determined by your latitude & longitude and the longitude of the satellite. In general terms the elevation angle will be low when you are at a high latitudes and will increase as you get closer to the equator.

Additionally, from any given latitude, the elevation will be highest when the satellite is at the same longitude that you are on. If the satellite is east, or west, of your longitude the elevation angle will be lower.

3.2.3. Antenna polarization

Your system has a **circular** polarization feed installed, you do not need to adjust the “polarization” of the antenna.

3.2.4. Stabilization

Your antenna is stabilized in all three axes of motion. Stabilization is the process of de-coupling the ships' motion from the antenna. Simply put, this allows the antenna to remain pointed at a point in space while the boat turns, rolls or pitches under it. To accomplish this, the Pedestal Control Unit (PCU) on the antenna pedestal assembly senses the motion and applies drive to the appropriate motor(s) in opposition to the sensed motion. Azimuth (AZ), Elevation (EL) and Cross-Level (left-right tilt) are actively stabilized automatically by the PCU as part of its normal operation.

3.2.5. Search Pattern

Whenever the desired satellite signal is lost (such as when the antenna is blocked) the Antenna Control Unit will automatically initiated a Search to re-acquire the desired signal.

Search is conducted in a two-axis pattern consisting of alternate movements in azimuth and elevation. The size and direction of the movements are increased and reversed every other time resulting in an expanding square pattern.

When the antenna is able to re-acquire the desired signal the ACU will automatically stop searching and begin Tracking the signal to optimize the pointing of the antenna to get the highest signal level from the satellite.

3.2.6. Tracking Receiver – Single Channel Per Carrier Receiver

The SCPC Narrow Band Receiver located in the Antenna Control Unit (ACU) is used to acquire, identify and track a narrow band carrier, or beacon signal, or the desired satellite. When properly setup, the settings for the satellite are saved to expedite future acquisition of the desired satellite. The system must have adequate satellite signal level to stop searching (and begin tracking the acquired satellite).

3.2.7. Tracking

Your Antenna Control Unit actively optimizes the pointing of the dish for maximum signal reception. This process is called **tracking** and is accomplished by continuously making small movements of the dish while monitoring the level of the received signal. Evaluation of this information is used to continuously move the stabilization point toward peak satellite signal reception. These minor pointing corrections keep the signal level “peaked” as part of normal operation.

3.3. Components of the System Configuration

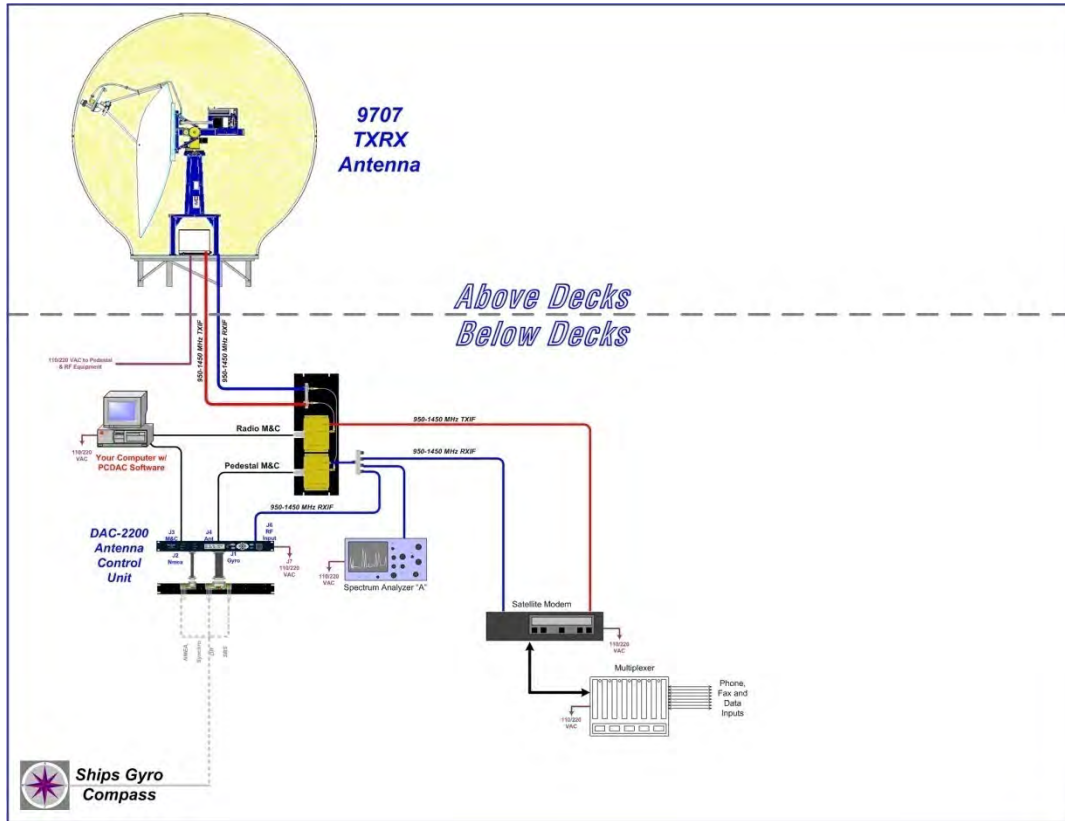

Figure 3-1 9707 TXRX Simplified Block Diagram

The following text provides a basic functional overview of the system components and component interconnection as referred to in the simplified block diagram for your 9707 antenna. Also, refer to the appropriate page of the System Block Diagram which depicts your system configuration.

3.3.1. Antenna ADE Assembly

The Above Decks Equipment consists of an Antenna Pedestal inside a Radome assembly. The pedestal consists of a satellite antenna dish & feed with a linear, or a circular Low Noise Block converter (LNB) with polarization motor mounted on a stabilized antenna pedestal. The radome provides an environmental enclosure for the antenna pedestal assembly inside it. This keeps wind, water condensation and salt-water spray off the antenna pedestal assembly. This prevents damage and corrosion that would shorten the expected life span of the equipment.

Two coaxial cables are connected from the antenna radome assembly to the below decks equipment. One of these cables includes the Antenna Control signaling and IF, the other cable carries the other IF signal.

These cables ultimately provide the input/output signals into/out of the satellite modem.

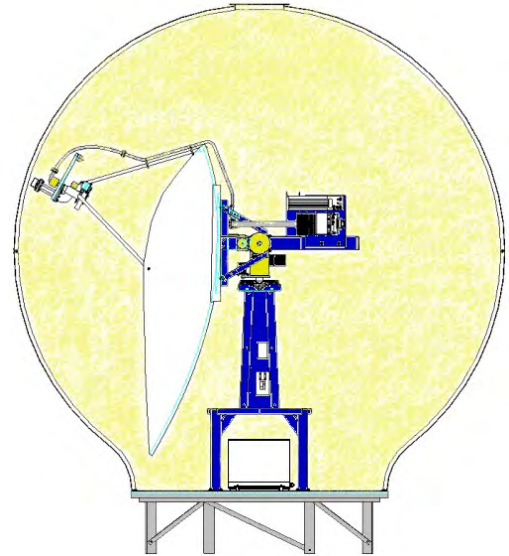

Figure 3-2 Series 97 TXRX Above Decks Equipment

3.3.2. Antenna Control Unit

The Antenna Control Unit allows the operator to control and monitor the antenna pedestal with dedicated function buttons, LED's and a 2 line display. The ACU and its Terminal Mounting Strip are normally mounted in a standard 19" equipment rack. The ACU should be mounted in the front of the equipment rack where it is easily accessible. The Terminal Mounting Strip is normally mounted on the rear of the equipment rack. It is recommended that the antenna control panel be mounted near one of the Satellite Receiver locations where you can see the television screen while you are controlling the antenna.

The Antenna Control Unit is connected to the antenna, ships Gyro Compass and modem.



Figure 3-3 Antenna Control Unit

The Antenna Control Unit (ACU) communicates via an RS-422 full duplex data link with the Pedestal Control Unit (PCU) located on the antenna. This control signal to/from the antenna is on the Coax cable along with the DC voltage which energizes the LNB and the L-Band Receive IF from the LNB. The Pedestal Control Unit stabilizes the antenna against the ship's roll, pitch, and turning motions. The ACU is the operator interface to the PCU and provides the user with a choice of positioning commands to point the antenna, search commands to find the satellite signal and tracking functions to maintain optimum pointing.

3.3.3. Above Decks AC Power Supply

Pedestal Power - An appropriate source of AC Voltage (110 VAC 60 Hz OR 220 VAC 50 Hz) is required for the above decks equipment. Total power consumption will depend on the number of equipments connected to this power source.

RF Equipment (TX/RX Systems ONLY) - The AC voltage source should be well regulated and surge protected. Uninterrupted Power Supplies are frequently installed (below decks) to provide power for the antenna pedestal, especially if RF Equipment is installed on the pedestal. Refer to the Specifications section of this manual for the power consumption of the antenna pedestal and RF Equipment.

Marine Air Conditioner Unit (TX/RX Systems ONLY) - If a marine air conditioner is included with your system, the AC voltage source should be from a separate AC Power breaker source than the antenna pedestal. AC power for the air conditioner should be well regulated and surge protected, but does NOT need to from an Uninterrupted Power Supply. Refer to the marine air conditioner manual for its' power requirements and consumption specifications.

3.4. **Positive Satellite ID**

The ACU has the means of positively identifying a satellite either internally (DVB compliant transponders) or Externally (Modem lock indication via Ethernet, OpenAMIP, or via an analog DC input into the TMS.

For internal satellite ID, all of the DVB receiver parameter settings must be set to match that of the inbound transponder.

For external satellite ID, the NID value must be set to 0000 and the system type parameter must include the 2 value at minimum.

- For OpenAMIP compatible satellite modems, an Ethernet cable connection to the ACU's Ethernet port is required. NOTE: The modems option file must be built to enable the appropriate Rx lock indication.
- For non-OpenAMIP compatible satellite modems, 2 wires coming from the Satellite modems must be connected to the AGC and Ground input pins of the TMS.

3.5. **Open Antenna-Modem Interface Protocol (OpenAMIP™) Specification:**

3.5.1. **Overview:**

OpenAMIP, an ASCII message based protocol invented and Trademarked by iDirect is a specification for the interchange of information between an antenna controller and a satellite modem. This protocol allows the satellite modem to command the ACU (via TCP port 2002) to seek a particular satellite as well as allowing exchange of information necessary to permit the modem to initiate and maintain communication via the antenna and the satellite. In general, OpenAMIP is not intended for any purpose except to permit a modem and the ACU to perform synchronized automatic beam switching. It is **NOT** a status logging system or a diagnostic system. In addition, OpenAMIP is intend for a typical installation whereby a specific satellite modem and Antenna system are properly configured to work together. The protocol does not make specific provisions for auto-discovery or parameter negotiation. It is still the responsibility of the installer to assure the parameters of both the satellite modem (proper option files) and the ACU/PCU (setup parameters) are actually compatible for the intended satellite(s).

3.5.2. **Interface requirements:**

3.5.2.1. **Hardware**

Sea Tel Antenna Control Units Model DAC2202 or DAC2302.

Any Satellite modem manufacturer that is compatible with OpenAMIP

CAT5 Patch cable

3.5.2.2. **Software**

Sea Tel model DAC2202:

ACU software version 6.06 or greater

CommIF module software version 1.11 or greater

Sea Tel model DAC2302:

ACU software version 7.06 or greater

CommIF module software version 1.11 or greater

3.5.3. Utilized OpenAMIP Commands:**3.5.3.1. Antenna Commands:**

Command	Description	Example
S f1 f2 f3	Satellite Longitude, 3 parameters: Degrees E/W (-value equals West), Latitude Variance (Inclined Orbit), Sat Skew Offset	"S -20.1 1.0 3.5"
P c1 c2	Polarization, 2 parameters: H,V,L,, or R	"P L R"
H f1 f2	Tracking Frequency: 2 Parameters: Center Frequency and Bandwidth in MHz	"H 14123.321 0.256"
B f1 f2	Down Conversion Offset: 2 parameters: LNB (Receive) Local Oscillator and BUC (TX) L.O.	"B 10750"
F	Find, Target satellite using existing S, P,R, and H Parameters	
A i	Set keep alive in seconds (0 = off)	"A 5"
L b1 b2	Modem Lock and free to transmit. 2 parameters: b1 indicates Rx lock and b2 (not utilized) enables/disables Tx Mute to BUC	"L 1 1"
W i	GPS Update: Sets GPS Update period in seconds (0 = Off)	"W 300"
I s1 s2	Set modem vendor (s1) and device (s2) 2 parameters:	"I iDirect 5100"

3.5.3.2. Modem Commands:





Command	Description	Example
a i	Set keep alive in seconds (0 = off)	"a 5"
i s1 s2	Set Antenna Vendor (s1) and device (s2) 2 parameters:	"i Sea Tel DAC-2202"
s b1 b2	Antenna Status: 2 parameters: b1 is functional status and b2 is Tx allowed	"s 1 1"
w b1 f1 f2 t1	Set GPS Position: 4 parameters: b1 is validity flag, f1 is latitude, f2 is longitude, and t1 is timestamp	"w 1 38.222 122.123 0"



THIS PAGE INTENTIONALLY LEFT BLANK

4. Installation

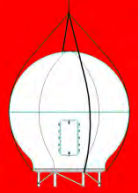
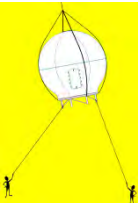
This section contains instructions for unpacking, final assembly and installation of the equipment. It is highly recommended that final assembly and installation of the Antenna system be performed by trained technicians. Read this complete section before starting.

4.1. General Cautions & Warnings

	<p>WARNING: Assure that all nut & bolt assemblies are tightened according the tightening torque values listed below:</p> <table border="1" data-bbox="516 617 1230 842"> <thead> <tr> <th>Bolt Size</th> <th>Inch Pounds</th> </tr> </thead> <tbody> <tr> <td>1/4-20</td> <td>75</td> </tr> <tr> <td>5/16-18</td> <td>132</td> </tr> <tr> <td>3/8-16</td> <td>236</td> </tr> <tr> <td>1/2-13</td> <td>517</td> </tr> </tbody> </table>	Bolt Size	Inch Pounds	1/4-20	75	5/16-18	132	3/8-16	236	1/2-13	517		
Bolt Size	Inch Pounds												
1/4-20	75												
5/16-18	132												
3/8-16	236												
1/2-13	517												
	<p>NOTE: All nuts and bolts should be assembled using the appropriate Loctite thread-locker product number for the thread size of the hardware.</p> <table border="1" data-bbox="516 932 1230 1199"> <thead> <tr> <th>Loctite #</th> <th>Description</th> </tr> </thead> <tbody> <tr> <td>222</td> <td>Low strength for small fasteners.</td> </tr> <tr> <td>243</td> <td>Medium strength, oil tolerant.</td> </tr> <tr> <td>680</td> <td>High strength for Motor Shafts & Sprockets.</td> </tr> <tr> <td>271</td> <td>Permanent strength for up to 1" diameter fasteners.</td> </tr> <tr> <td>290</td> <td>Wicking, High strength for fasteners which are already assembled.</td> </tr> </tbody> </table>	Loctite #	Description	222	Low strength for small fasteners.	243	Medium strength, oil tolerant.	680	High strength for Motor Shafts & Sprockets.	271	Permanent strength for up to 1" diameter fasteners.	290	Wicking, High strength for fasteners which are already assembled.
Loctite #	Description												
222	Low strength for small fasteners.												
243	Medium strength, oil tolerant.												
680	High strength for Motor Shafts & Sprockets.												
271	Permanent strength for up to 1" diameter fasteners.												
290	Wicking, High strength for fasteners which are already assembled.												
	<p>WARNING: Hoisting with other than a webbed four-part sling may result in catastrophic crushing of the radome. Refer to the specifications and drawings for the fully assembled weight of your model Antenna/Radome and assure that equipment used to lift/hoist this system is rated accordingly.</p>												
	<p>CAUTION: The antenna/radome assembly is very light for its size and is subject to large swaying motions if hoisted under windy conditions. Always ensure that tag lines, attached to the radome base frame, are attended while the antenna assembly is being hoisted to its assigned location aboard ship.</p>												
	<p>WARNING: Electrical Hazard – Dangerous AC Voltages exist inside the Antenna Pedestal Breaker Box. Observe proper safety precautions when working inside the Pedestal Breaker Box.</p>												
	<p>WARNING: Electrical Hazard – Dangerous AC Voltages exists on the side of the Antenna Pedestal Power Supply. Observe proper safety precautions when working inside the Pedestal Power Supply.</p>												

	<p>WARNING: RF Radiation Hazard - This stabilized antenna system is designed to be used with transmit/receive equipment manufactured by others. Refer to the documentation supplied by the manufacturer which will describe potential hazards, including exposure to RF radiation, associated with the improper use of the transmit/receive equipment. Note that the transmit/receive equipment will operate independently of the stabilized antenna system.</p> <p>The ultimate responsibility for safety rests with the facility operator and the individuals who work on the system.</p>
	<p>WARNING: RF Radiation Hazard - Prior to working on the stabilized antenna system, the power to the transmit/receive equipment must be locked out and tagged. Turning OFF power to the Antenna Control Unit does NOT turn Transmit power output OFF.</p> <p>The ultimate responsibility for safety rests with the facility operator and the individuals who work on the system.</p>
	<p>WARNING: RF Radiation Hazard - When the transmit/receive system is in operation, no one should be allowed anywhere within the radiated beam being emitted from the reflector.</p> <p>The ultimate responsibility for safety rests with the facility operator and the individuals who work on the system.</p>

4.2. Site Survey

The radome assembly should be installed at a location aboard ship where:

1. The antenna has a clear line-of-sight to as much of the sky (horizon to zenith at all bearings) as is practical.
2. Direct radiation into the antenna from ships radar, especially high power surveillance radar arrays, is minimized. The radome should be as far away from the ships Radar as possible and should NOT be mounted on the same plane as the ships Radar (so that it is not directly in the Radar beam path).
3. The radome should be as far away from the ships high power short wave (MF & HF) transmitting antennas as possible.
4. The Above Decks Equipment (ADE) and the Below Decks Equipment (BDE) should be positioned as close to one another as possible. This is necessary to reduce the losses associated with long cable runs.
5. The mounting location is rigid enough that it will not flex, or sway, in ships motion or vibration. If the radome is to be mounted on a raised pedestal, it **MUST** have adequate gussets, or be well guyed, to prevent flexing or swaying in ships motion.

If these conditions cannot be entirely satisfied, the site selection will inevitably be a “best” compromise between the various considerations.

4.3. Preparing For The Installation

4.3.1. Unpack Shipping Crates

Exercise caution when unpacking the equipment.

4.3.2. Inspect / Inventory

Carefully inspect the radome panel surfaces for evidence of shipping damage. Inspect the pedestal assembly and reflector for signs of shipping damage.

4.3.3. Prepare ADE Mounting Location

Prepare the mounting location for the Radome. If the radome is to be bolted to the deck (or a platform) assure that the mounting holes have been drilled. Assure that the mounting hardware has obtained and is readily available.

4.3.4. Preparing BDE Location

Prepare the mounting location for the Below Decks Equipment. These equipments would normally be installed in a standard 19” equipment rack. Refer to the Antenna Control Unit manual for installation of the ACU and the Terminal Mounting Strip.

Refer to the vendor supplied manuals for installation of the other below decks equipments.

Prepare other locations throughout ship for any other equipment which is not co-located with the ACU.

4.3.5. Installing The System Cables

Install appropriate cables from Below Decks Equipment to the ADE Location(s).

The cables must be routed from the above-decks equipment group through the deck and through various ship spaces to the vicinity of the below-decks equipment group. When pulling the cables in place, avoid the use of excessive force. Exercise caution during the cable installation to assure that the cables are not severely bent (proper bend radius), kinked or twisted and that connectors are not damaged.

Assure that the cables have been run through watertight fittings and/or will not permit water entry into the ship when the installation is completed. After cables have been routed and adjusted for correct cable length at each end, seal the deck penetration glands and tie the cables securely in place.

4.4. Assembling the ADE

4.4.1. 144” Radome, Baseframe and Antenna Pedestal System Assembly

Refer to the System Block diagram, General Assembly, Radome Assembly and Base frame Assembly drawings for your system.



NOTE: Unless otherwise indicated, all nuts and bolts should be assembled with Loctite 271 or its equivalent.



WARNING: Assure that all nut & bolt assemblies are tightened according the tightening torque values listed below:

Bolt Size	Inch Pounds
1/4-20	75
5/16-18	132
3/8-16	236
1/2-13	517

1. Select a secure assembly site that provides enough area to work with the large radome panels. Place the radome base pan on temporary support blocks at least 22 inches high.
2. Assemble the radome base frames eight legs and eight braces using the hardware provided. Loosely assemble all legs and braces aligning all matching marks before tightening any of the bolts. Insure that a split washer is used under each nut.
3. Refer to the radome assembly drawing. Observe the painted numbers on the radome panels that clearly identify their positions respective to each other and the base pan assembly.
4. Loosely assemble the 6 lower side panels, using the hardware provided, to form the bottom half of the radome. Do NOT tighten the bolts at this time. Open each seam wide enough to install a good bead of silicone caulk, then firmly tighten all the bolts in that flange. Repeat until all flanges are sealed.

5. Loosely assemble the 6 upper side panels, using the hardware provided, to form the upper half of the radome. Do NOT tighten the bolts at this time. Open each seam wide enough to install a good bead of silicone caulk, then firmly tighten all the bolts in that flange. Repeat until all flanges are sealed.
6. Apply a good bead of silicone caulk all the way around the top cap. Install the cap into the upper radome panel assembly using the hardware provided and tighten all the bolts.
7. Set the lower half of the radome assembly on the base pan aligning the painted numbers on the radome panels. Loosely attach the lower side panel assembly to the base frame using the hardware provided. Do NOT tighten the bolts at this time. Lift the lower side panel assembly wide enough to install a good bead of silicone caulk between it and the base pan, then firmly tighten all the bolts.
8. Fasten the antenna pedestal assembly, complete with base stand, to the base pan using the 1/2-13 x 1 1/2 (or the 3/8-16 x 1 1/2) inch bolts inserted from the bottom up and install a flat washer, a lock washer and a nut in each mounting hole. Apply Loctite 271 and tighten securely.
9. Attach the antenna assembly (reflector, struts and feed) to the stabilized pedestal, by using the reflector mounting hardware provided. Position the antenna over the four antenna support struts (the antenna and the dish mounting clips are numbered or color coded make sure they match). Insert the four mounting bolts, washers and nuts, apply Loctite 271 and tighten.
10. Attach the 15 pin connector on the antenna reflector harness to the shielded Polang Aux Relay box. Connect the IF receive coax cables from the feed to the pedestal Modem or coax relay/switch panel according to the block diagram.
11. Using a four point web lifting sling and lifting clips, lift the upper half of the radome up over the antenna pedestal and set it onto the lower side panels aligning the painted numbers on the radome panels. Loosely attach the upper and lower halves of the radome using the hardware provided. Do NOT tighten the bolts at this time. Insert wedges between the upper side panel assembly and the lower side panel assembly to hold open a space wide enough to install a good bead of silicone caulk between it and the lower side panels, then remove the wedges and firmly tighten all the bolts.
12. Gently restrain the antenna prior to lifting the ADE onto the ship to restrict movement inside the radome during the lift.

4.4.2. Preparing the ADE for Lift

Install Stow Braces, or other restraints, on the Antenna Pedestal. Attach shackles and web type lifting harness to the four lifting holes in the base-frame.

4.5. Installing The ADE

4.5.1. Hoist

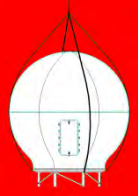
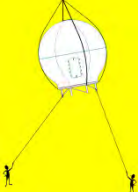
	<p>WARNING: Hoisting with other than a webbed four-part sling may result in catastrophic crushing of the radome. Refer to the specifications and drawings for the fully assembled weight of your model Antenna/Radome and assure that equipment used to lift/hoist this system is rated accordingly.</p>
	<p>CAUTION: The antenna/radome assembly is very light for its size and is subject to large swaying motions if hoisted under windy conditions. Always ensure that tag lines, attached to the radome base frame, are attended while the antenna assembly is being hoisted to its assigned location aboard ship.</p>

1. Assure that the antenna is restrained before hoisting. Check that all nuts on the base frame assembly are tightened according the torque values listed below:
2. Using a four-part lifting sling, and with a tag line attached to the radome base frame, hoist the antenna assembly to its assigned location aboard ship by means of a suitably-sized crane or derrick.
3. The radome assembly should be positioned with the BOW marker aligned as close as possible to the ship centerline. Any variation from actual alignment can be compensated with the AZIMUTH TRIM adjustment in the ACU, so precise alignment is not required.

4.5.2. Install Antenna/Radome/Baseframe

Bolt, or weld, the legs of the radome base frame directly to the ship's deck. If the deck is uneven or not level, weld clips to the deck and attach them to the legs of the radome base frame. When completed the radome base must be level.

4.5.3. Cooling Unit Assembly - TX SYSTEMS ONLY

If cooling unit is supplied, refer to the drawings provided for detailed instructions on assembly and installation of the cooling unit and any associated intake and exhaust diffusion ducting.

4.6. *Install BDE Equipment*

4.6.1. ACU & TMS

Refer to the Antenna Control Unit manual for installation of the ACU and the Terminal Mounting Strip.

4.6.2. Other BDE Equipment

Refer to the vendor supplied manuals for installation of the other below decks equipment.

4.7. *Cable Terminations*

4.7.1. At The Radome

The TX and RX, or TVRO IF, cables must be inserted through the cable strain reliefs at the base of the radome. Apply RTV to the strain relief joints and tighten the compression fittings to make them watertight. Attach the pedestal cable adapters to the TX and RX, or TVRO IF, cables from below decks. Refer to the System Block Diagram.

AC Power cable for the Antenna Pedestal and RF Equipment is routed into the AC Power Breaker box and connected to the breaker terminals.

Sea Tel recommends that separate, dedicated, AC Power be provided for the Marine Air Conditioner (Do NOT combine with the AC Power provided for the Antenna Pedestal and RF Equipment). This AC Power cable is routed into the Marine Air Conditioner and terminated to the AC terminals inside.

4.7.2. ACU & TMS

To Connect AC Power, Gyro Compass Connection and IF Input refer to the Antenna Control Unit manual. Installation of optional (remote) Pedestal, and /or Radio, Monitor & Control connection(s) from a PC Computer are also contained in the ACU manual.

4.7.3. Other BDE Equipment

Refer to the vendor supplied manuals for installation of the other below decks equipment.

4.8. *Final Assembly*

4.8.1. Mount RF Equipment (TXRX Only)

Install the RF equipment on the elevation beams (TXRX Systems ONLY) Connect the TXIF & RXIF cables, RF Transmit and Receive waveguide sections from the appropriate feed (C-Band or Ku-Band) to the appropriate SSPA or TWTA and Radio package (C-Band Pair or Ku-Band pair) according to the block diagram.

4.8.2. Remove Stow Braces/Restraints

Remove the restraints from the antenna and verify that the antenna moves freely in azimuth, elevation, and cross level without hitting any flanges on the radome.

4.8.3. Verify all assembly and Wiring connections

Verify that all pedestal wiring and cabling is properly dressed and clamped in place.

4.8.4. Balance Antenna Pedestal

Assure that the antenna assembly is balanced front to back, top to bottom and side to side by observing that it remains stationary when positioned in any orientation. Refer to the Maintenance section for complete information on balancing the antenna.

4.9. *Power-Up The ADE*

Turn Pedestal AC power breaker ON.

4.9.1. Initialization

Turn the pedestal power supply ON. The PCU will initialize the stabilized portion of the mass to be level with the horizon and at a prescribed Azimuth and Elevation angles. The antenna will go through the specific sequence of steps to initialize the level cage, elevation, cross-level and azimuth to predetermined starting positions. Each phase must complete properly for the antenna to operate properly (post-initialization). Refer to the initialization text in the Troubleshooting section in this manual. Observe the Initialization of the antenna pedestal.

If any of these steps fail, or the ACU reports model "xx97", re-configure the PCU as described in the Setup section of this manual. If initialization still fails, this indicates a drive or sensor problem, refer to the Troubleshooting section.

4.9.2. Home Flag Position

Note the approximate position of the antenna relative to the bow of the ship while it is at the home switch position. This information will be used later to calibrate the relative position display of the antenna.

4.9.3. BDE

Turn Power ON to the ACU. Record the power-up display, Master (ACU) Model & Software version and the Remote (PCU) Model & Software version.

4.10. *Setup*

Refer to the Setup information in the next section of this manual and in the Setup section of your ACU Manual.

5. Setup

Below are basic steps to guide you in setting up the ACU for your specific antenna pedestal. Assure that the Antenna Pedestal (ADE) has been properly installed before proceeding. Refer to the Setup section of your ACU manual for additional parameter setting details.

5.1. Operator Settings

Refer to the Operation chapter of this manual to set the Ship information. Latitude and Longitude should automatically update when the GPS engine mounted above decks triangulates an accurate location, but you may enter this information manually to begin. If your gyro source is providing Heading information in any format other than NMEA-0183 format, you will have to enter in the initial Ship's Heading position, the Gyro Compass will then keep the ACU updated.

Set the Satellite information, for the satellite you will be using. The receiver settings are especially important. At this point you should be able to target the desired satellite. Continue with the setup steps below to optimize the parameters for your installation.

5.2. Optimizing Targeting (Auto Trim)

The following feature requires your antenna have GSR2 minimum software versions installed. First, assure that all of your Ship & Satellite settings in the ACU are correct. Target and, if required manually locate the desired satellite. Allow 1 to 2 minutes for the antenna to "peak" on the signal. Verify positive satellite identification, in a TVRO system verify either Receive NID or that at least one Television is producing video, in a VSAT system verify receive lock indication on the satellite modem.

Access the ACU Setup Mode Parameter "AUTO TRIM", Press the UP arrow and then press Enter.

Drive the antenna completely off satellite (Target and Azimuth value of 0)

Retarget the satellite and verify the system peaks on satellite with positive satellite identification within 1 minute.

Access the ACU Setup Modes "SAVE NEW PARAMETERS", Press the UP arrow and then press Enter

5.3. Optimizing Targeting (Manually)

First, assure that all of your Ship & Satellite settings in the ACU are correct. Target the desired satellite, immediately turn Tracking OFF, and record the Azimuth and Elevation positions in the "ANTENNA" display of the ACU (these are the **Calculated** positions). Turn Tracking ON, allow the antenna to "Search" for the targeted satellite and assure that it has acquired (and peaks up on) the satellite that you targeted. Allow several minutes for the antenna to "peak" on the signal, and then record the Azimuth and Elevation positions while peaked on satellite (these are the **Peak** positions). Again, assure that it has acquired the satellite that you targeted!

Subtract the Peak Positions from the Calculated Positions to determine the amount of Trim which is required. Refer to the ACU Setup information to key in the required value of Elevation Trim. Continue with Azimuth trim, then re-target the satellite several times to verify that targeting is now driving the antenna to a position that is within +/- 1.0 degrees of where the satellite signal is located.

EXAMPLE: The ACU targets to an Elevation position of 30.0 degrees and an Azimuth position of 180.2 (Calculated), you find that Peak Elevation while ON your desired satellite is 31.5 degrees and Peak Azimuth is 178.0. You would enter an EL TRIM value of -1.5 degrees and an AZ TRIM of +2.2 degrees. After these trims values had been set, your peak **on satellite** Azimuth and Elevation displays would be very near 180.2 and 30.0 respectively.

5.4. Optimizing Auto-Polarization TX/RX

This procedure optimizes the linear polarization of the feed, if your system is fitted with a circular feed you do not need to optimize the polarity angle and can skip this procedure. At the ACU, turn tracking and DishScan Drive off. Drive Elevation to horizon. Drive Azimuth to an angle that allows the above decks technician a clear view of the feed assembly. Verify that Polang Type is set to 9 and POL OFFSET is set to 30. Access the POL sub menu (Antenna sub-menu). At the ACU drive the feed assembly to pure vertical. At the antenna, disengage the POL Pot and as required rotate the Pol Pot shaft until the displayed POL counts equal 120 and reengage the POL POT. Reset Polang Type to 72. Re-enable DishScan Drive. Target and track your desired satellite. Assure that you are peak on satellite and then access the Skew parameter (Located in the SAT sub-menu under the tracking parameters) Under guidance from the NOC, enter in the intentional satellite skew of the current satellite beam, if any as a starting point.

If no skew is required, start with an initial skew value of 00. While transmitting a pure carrier wave, increment/decrement the SKEW parameter as required to achieve proper Cross-Pol Isolation. Each increment equals one degree of polarization rotation, decrement below 0 for minus polarization. To increment or the DOWN arrow to decrement the value and then hit the ENTER key to adjust the feed to the new value. Once the optimized SKEW value has been established, access the SAVE NEW PARAMETERS window and submit the settings to memory.

5.5. Calibrating Relative Antenna Position (Home Flag Offset)

During initialization, azimuth drives the CW antenna until the Home Switch is contacted, which “presets” the relative position counter to the value stored in the Home Flag Offset. This assures that the encoder input increments/decrements from this initialization value so that the encoder does not have to be precision aligned.

The Home Switch is a micro switch with a roller arm which is actuated by cam mounted on the azimuth driven sprocket, or it is a hall sensor which is actuated by a magnet mounted on the azimuth driven sprocket, which produces the “Home Flag” signal.

The Home Flag Offset is a value saved in NVRam (Non-Volatile RAM) in the PCU. This value is the relative position of the antenna when the home switch is engaged. Presetting the counter to this value assures that when the antenna is pointed in-line with the bow of the ship the counter will read 000.0 **Relative** (360.0 = 000.0).

In most cases when the antenna stops at the home flag, it will be pointed in-line with the Bow of the ship. In these cases Home Flag Offset (HFO) should be set to zero. When “Optimizing Targeting” small variations (up to +/- 5.0 degrees) in Azimuth can be corrected using If it AZ TRIM as described in the Optimizing Targeting procedure above.

Large variations in Azimuth position indicate that the Relative position is incorrect and should be “calibrated” using the correct HFO value instead of an Azimuth Trim offset. This is especially true if sector blockage mapping is used.

If the antenna stops at the home flag, but it is NOT pointed in-line with the Bow of the ship, it is important to assure that the antennas **actual** position (relative to the bow of the ship) is the value that gets “preset” into the Relative position counter. By saving the antennas **actual** Relative position when at the home flag into HFO, you have calibrated the antenna to the ship.

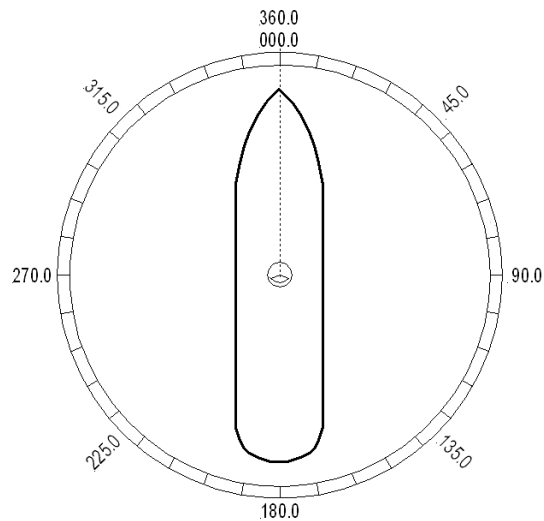

Figure 5-1 Antenna stops In-line with Bow

5.5.1. To Calculate HFO:

If Targeting has been optimized by entering a large value of AZ TRIM; First, verify that you are able to repeatedly accurately target a desired satellite (within +/- 1.0 degrees). Then you can use the AZ TRIM value to calculate the value of HFO you should use (so you can set AZ TRIM to zero). AZ Trim is entered as the number of **tenths** of degrees. You will have to convert the AZ TRIM value to the nearest **whole** degree (round up or down as needed). Calculated HFO value is also rounded to the nearest whole number.

If AZ TRIM was a **plus** value: $HFO = (TRIM / 360) \times 255$ Example: AZ TRIM was 0200 (plus 20 degrees). $HFO = (20/360) \times 255 = (0.0556) \times 255 = 14.16$ round off to 14.

If AZ TRIM was a **negative** value: $HFO = ((360-TRIM) / 360) \times 255$ Example: AZ TRIM = -0450 (minus 45 degrees). $HFO = ((360 - 45) / 360) \times 255 = (315 / 360) \times 255 = 0.875 \times 255 = 223.125$ round of to 223.

If Targeting has NOT been optimized, allow the antenna to initialize to its home flag position. Visually compare the antennas pointing to the bow-line of the ship (parallel to the Bow). Note the antennas position relative to the Bow. If it appears to be very close to being parallel to the bow, HFO will probably not be needed and you can proceed with Optimizing Targeting. If it is NOT close, initialization was driving the azimuth CW, note if the antenna appears to have stopped before it got to the Bow or if it went past the Bow. You may be able to guess an approximate amount of how many degrees the antenna is from the bow. This is only intended to help you initially find the satellite (which direction you will have to drive and approximately how far you will have to drive). Refer, in general terms, to the Optimizing Targeting procedure.

If the antenna stopped before it got to the bow-line; When you initially target a satellite, the antenna will also stop prior to the satellite position, so you that will have to drive the Azimuth of the antenna UP to actually find the satellite. Using the same basic procedure as in the Optimizing Targeting paragraph, target the satellite and record the “Calculated” Azimuth position that the antenna was driven to. Drive UP until you find the satellite, positively identify that you are on **the satellite** you targeted and allow tracking to peak the antenna position. Record the “Peak” Azimuth position. Subtract the “Peak” position from the “Calculated” position to determine the number of degrees of AZ TRIM that would be required.

Example: In this new installation, I target my desired satellite and record the Calculated Azimuth to be 180.5. I drive UP and finally find my desired satellite at a Peak Azimuth of 227.0 degrees. I subtract Peak from Calculated and difference to be – 46.5 degrees, therefore the actual Relative position that needs to be preset into the counter when the antenna is at the Home Flag is 313.5. $HFO = ((360 - 46.5) / 360) \times 255 = (313.5 / 360) \times 255 = 0.87 \times 255 = 222.06$ which I round down to 222.

If the antenna went past the bow-line; When you initially target a satellite, the antenna will also go past the satellite position, so that you will have to drive the Azimuth of the antenna DOWN to actually find the satellite. Using the same basic procedure as in the Optimizing Targeting paragraph, target the satellite and record the “Calculated” Azimuth position that the antenna was driven to. Drive DOWN until you find the satellite, positively identify that you are on **the satellite** you targeted and allow tracking to peak the antenna position. Record the “Peak” Azimuth position. Subtract the “Peak” position from the “Calculated” position to determine the number of degrees of AZ TRIM that would be required. . Refer to the calculations above to determine the HFO you should use for this antenna.

Example: In this new installation, I target my desired satellite and record the Calculated Azimuth to be 180.0. I drive DOWN and finally find my desired satellite at a Peak Azimuth of 90.0 degrees. I subtract Peak from Calculated and difference to be +90.0 degrees, therefore the actual Relative position that needs to be preset into the counter when the antenna is at the Home Flag is 90.0. $HFO = ((90.0) / 360) \times 255 = 0.25 \times 255 = 63.75$ which I round up to 64.

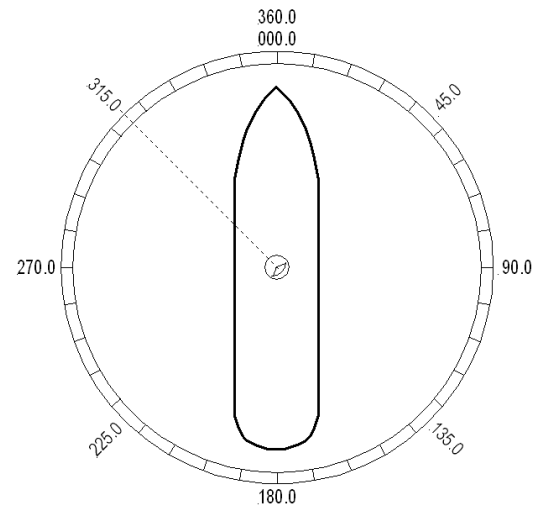

Figure 5-2 Antenna stopped before the Bow

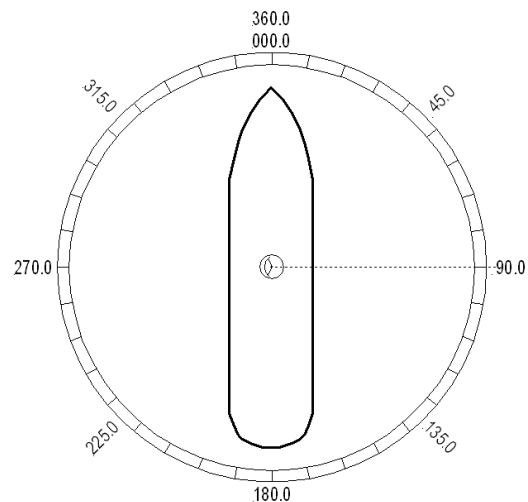

Figure 5-3 Antenna stops past the Bow

5.5.2. To Enter the HFO value:

To enter the calculated HFO value, press & hold both LEFT and RIGHT arrows for six seconds to enter the parameter menu at the EL TRIM parameter window. Press DOWN arrow key numerous times (about 21) until you have selected the REMOTE COMMAND window.

In the REMOTE COMMAND window, press the LEFT arrow key until you have underscored the left most character in the displayed value (ie the A in "A0000"). Use the UP/DOWN arrow keys to increment/decrement the underscored character until it is upper case N ("N0000" should appear in the command window). Press the RIGHT arrow key to move the cursor under the most significant digit, then use the UP arrow key to increment it to a value of 6 (the display is now "N6000"). Set the three digits to the right of the 6 to the three digit HFO value from 000 to 255 (corresponding to 0 to 360 degrees) that you calculated above. Use the LEFT/RIGHT keys to underscore the desired digit(s) then use the UP/DONW arrow keys to increment/decrement the underscored value. When you have finished editing the display value, press ENTER to send the HFO value command to the PCU (but it is not save yet).

If you want to find out what the **current** HFO value is key in N6999 and hit **ENTER**.

When completed, you must save the desired HFO value. Press ENTER several times to select the REMOTE PARAMETERS display. Press the LEFT or RIGHT arrow key to enter writing mode and then press the ENTER to save the HFO value in the PCUs NVRAM.

EXAMPLE: In the "Antenna stopped before the Bow" example above, the HFO calculated was 222. To enter this value:

1. Set the Remote Command value to "**N6222**".
2. Press **ENTER** to send this HFO to the PCU. The display should now show "N0222".
3. When completed, you must save the desired HFO value. Press **ENTER** several times to select the **REMOTE PARAMETERS** display. Press the **LEFT** or **RIGHT** arrow key to enter writing mode and then press the **ENTER** to save the HFO value in the PCUs NVRAM.

You have to drive the antenna CW in azimuth until the home switch is actuated, or re-initialize the antenna to begin using the new HFO value you have entered and saved. To re-initialize the antenna from the REMOTE COMMAND window of the ACU;

1. Press **UP** arrow key several times to return to the **REMOTE COMMAND** display.
2. Press the **LEFT** or **RIGHT** arrow key to enter edit mode. Use the **LEFT/RIGHT** and **UP/DOWN** arrow keys to set the character and digits to "**0090**" and then press the **ENTER** key.

This resets the PCU on the antenna. The antenna will reinitialize with this command (Performs a similar function as a power reset of the antenna) and the new home flag offset value will be used to calibrate the Relative position of the antenna.

5.6. Radiation Hazard and Blockage Mapping (AZ LIMIT parameters)

This system may be programmed with relative azimuth and elevation sectors (zones) where blockage exists or where transmit power would endanger personnel who are frequently in that area.

Refer to your ACU Manual for instructions on programming of these zones.

5.7. TX Polarity Setup

With the feed in the center of its polarization adjustment range, observe the transmit port polarity (vector across the short dimension of the transmit wave-guide).

If the transmit polarity in the center of the travel range is vertical, use the following entries:

- 2 Vertical Transmit Polarity
- 4 Horizontal Transmit Polarity

If the Transmit polarity in the center of the travel range is horizontal, use the following entries:

- 2 Horizontal Transmit Polarity
- 4 Vertical Transmit Polarity

5.1. *Sat Skew setting*

The Satellite Skew setting in the Satellite – Tracking Receiver sub-menu (prior to NID) is used to enter the skew of the satellite to optimize polarity angle.

This feature will replace the use of POL OFFSET to optimize polarization of the feed. From here on out, POL OFFSET will serve to calibrate the feed itself. Think of it as mechanical calibration. We will recommend that you target a satellite that is of your same longitudinal position (ie for us here in Concord we would target 122W). Drive the reflector to 0 or 5 degrees elevation (this is so you can easily view the feed). Drive the feed to vertical and then place a level bubble on the LNB. Add or subtract POL OFFSET as required to center the air bubble. Then save this parameter. Cross-pol isolation tests will now require the operator to increase or decrease the SAT SKEW parameter. Each digit represented on this screen represents one whole degree of feed drive.

5.2. *Polarity Angle (POLANG) Parameters*

First of all make sure that the polang parameters are set correctly:

1. POL TYPE – should be set to 0072 (Auto-Pol mode).
2. POL OFFSET – This is initially set to factory default (0040) but will be incremented, or decremented, to calibrate the feed to the horizon with a level (bubble or digital).
3. POL SCALE – Leave this at the factory default setting of 0090.
4. Go to the TX POLARITY parameter in the Setup menu of the ACU and set this parameter to your assigned Transmit polarity (2=Horizontal or 4=Vertical).
5. Target your desired satellite (as provided by you airtime provider).
6. Verify the system has acquired the correct satellite, else continue searching until the correct satellite is acquired, and set your satellite modem (or spectrum analyzer) to view its signal level display.
7. Allow tracking to peak the satellite signal.
8. SAT SKEW – This setting will be incremented, or decremented, to optimize the polarity to peak the received satellite signal, and later to do cross-pol isolation with the airtime provider, network operation center or satellite provider.

5.3. Default Setup Parameters

The following table shows the factory default parameters for the Antenna Control Unit interfaced to a Series 07 Antenna PCU. When the installation & setup of your system is finished you can record the “optimized” settings for your system in the “My Parameters” column. Also refer to the ACU Manual for more in-depth information each of the individual parameters and how to enter, or change, the parameters.

PARAMETER	C-Band DishScan	My Parameters
EL TRIM	0	
AZ TRIM	0	
AUTO THRES	100	
EL STEP SIZE	0	
AZ STEP SIZE	0	
STEP INTEGRAL	0	
SEARCH INC	10	
SEARCH LIMIT	200	
SEARCH DELAY	30	
SWEEP INC	0040	
SYSTEM TYPE	13 *	
GYRO TYPE	0, 1, 2, 36, or 362	
POL TYPE	0	
POL OFFSET	30	
POL SCALE	90	
AZ LIMIT 1	0	
AZ LIMIT 2	0	
EL LIMIT 12	0900	
AZ LIMIT 3	0	
AZ LIMIT 4	0	
EL LIMIT 34	0900	
AZ LIMIT 5	0	
AZ LIMIT 6	0	
EL LIMIT 56	0900	
TX POLARITY	2 (Horizontal TX)	
TRACK DISP	0000	

*** Modem Lock input & Modem TX Mute functions are NOT set, refer to SYSTEM TYPE parameter information.**

6. Functional Testing

If not already ON, Turn ON the Power switch on the front panel of the ACU.

6.1. ACU / Antenna System Check

1. Turn ACU power ON. Turn antenna Pedestal/RF Equipment power ON
2. Press RESET on the ACU front panel of the ACU. Verify the display shows "SEA TEL INC - MASTER" and the ACU software version number. Wait 10 seconds for the display to change to "SEA TEL INC - REMOTE" and the PCU software version number. If the display shows "REMOTE INITIALIZING" wait for approximately 2 minutes for the antenna to complete initialization and report the Antenna Model and PCU software version.
3. Press the **Ship, Satellite, Antenna** and **Status** keys repeatedly to display their respective menus. This verifies that the displays change in the correct response to the keys.

If "REMOTE NOT RESPONDING" is displayed, or the displays do not change when the main menu keys are pressed, refer to the Troubleshooting Section of your ACU manual. Return to normal operation OR Continue with the next functional test.

6.2. ACU / Antenna System Check

1. Press RESET on the ACU front panel to initialize the system. Verify the display shows "SEA TEL INC - MASTER" and the ACU software version number. Wait 10 seconds for the display to change to "SEA TEL INC - REMOTE" and the PCU software version number. If the display shows "REMOTE INITIALIZING", wait approximately 2 minutes for the antenna to complete initialization and report the Antenna Model and PCU software version. If "REMOTE NOT RESPONDING" is displayed, refer to the Troubleshooting Section of this manual.
2. Press the **NEXT** key repeatedly to display the **Ship, Satellite, Antenna** and **Status** menu displays. This verifies that the displays change in the correct response to the keys.

6.3. Latitude/Longitude Auto-Update check

This verifies that the GPS antenna mounted on the antenna pedestal is automatically updating the current ship's position information. If the GPS is not updating the ACU properly, refer to the Troubleshooting Section of this manual.

1. Press the **NEXT** key repeatedly to display the **Ship** menu. Press **ENTER** to access edit mode and view the current Latitude value.
2. Press the **LEFT** arrow key to bring the cursor up under the ones digit, press **UP** and then hit **ENTER**. The display should immediately show a latitude value one degree higher. If the GPS engine mounted on the Antenna Pedestal is working properly the incorrect value will be overwritten within several seconds (back to the correct current value).
3. This test does not need to be repeated in the Longitude menu.

6.4. Azimuth & Elevation Drive

This check verifies that the antenna moves in the correct direction in response to the keys. If the antenna is not driving properly, refer to the Troubleshooting Section of this manual.

1. Press the **NEXT** key several times to display the **Antenna** menu.
2. Press the **Tracking** key to toggle Tracking OFF.
3. Press the **UP** arrow key repeatedly and verify that the antenna moves up in elevation.
4. Press the **DOWN** arrow key repeatedly and verify that the antenna moves down in elevation.
5. Press the **RIGHT** arrow key repeatedly and verify that the antenna moves up in azimuth.
6. Press the **LEFT** arrow key repeatedly and verify that the antenna moves down in azimuth.

6.5. Four Quadrant Tracking Test







This verifies that the antenna moves in the correct response to the keys, that Tracking is signaling correctly and that the Tracking commands are being carried out (antenna drives to peak).

1. Press the **NEXT** key several times to display the **Antenna** menu.

2. Note the current peak ACG value. Press the **Tracking** key to toggle Tracking OFF, press the **UP** arrow key repeatedly to move the antenna up in elevation until AGC falls about 100 counts. Turn Tracking ON and verify that the antenna moves back down in elevation and that the AGC rises to its' previous high value.
3. Note the current peak ACG value. Press the **Tracking** key to toggle Tracking OFF, press the **DOWN** arrow key repeatedly to move the antenna down in elevation until AGC falls about 100 counts. Turn Tracking ON and verify that the antenna moves back up in elevation and that the AGC rises to its' previous high value.
4. Note the current peak ACG value. Press the **Tracking** key to toggle Tracking OFF, press the **RIGHT** arrow key repeatedly to move the antenna up in azimuth until AGC falls about 100 counts. Turn Tracking ON and verify that the antenna moves back down in azimuth and that the AGC rises to its' previous high value.
5. Note the current peak ACG value. Press the **Tracking** key to toggle Tracking OFF, press the **LEFT** arrow key repeatedly to move the antenna down in azimuth until AGC falls about 100 counts. Turn Tracking ON and verify that the antenna moves back up in azimuth and that the AGC rises to its' previous high value.

7. Maintenance and Troubleshooting

This section describes the theory of operation to aid in troubleshooting and adjustments of the antenna system. Also refer to the Troubleshooting section of your ACU manual for additional troubleshooting details.

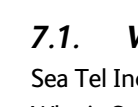
	WARNING: <i>Electrical Hazard – Dangerous AC Voltages exist in the Breaker Box and the Antenna Pedestal Power Supply. Observe proper safety precautions when working inside the Antenna Breaker Box or Power Supply.</i>
	WARNING: <i>RF Radiation Hazard - This stabilized antenna system is designed to be used with transmit/receive equipment manufactured by others. Refer to the documentation supplied by the manufacturer which will describe potential hazards, including exposure to RF radiation, associated with the improper use of the transmit/receive equipment. Note that the transmit/receive equipment will operate independently of the stabilized antenna system.</i>
	The ultimate responsibility for safety rests with the facility operator and the individuals who work on the system.
	WARNING: <i>RF Radiation Hazard - Prior to working on the stabilized antenna system, the power to the transmit/receive equipment must be locked out and tagged. Turning OFF power to the Antenna Control Unit does NOT turn Transmit power output OFF.</i>
	The ultimate responsibility for safety rests with the facility operator and the individuals who work on the system.
	WARNING: <i>RF Radiation Hazard - When the transmit/receive system is in operation, no one should be allowed anywhere within the radiated beam being emitted from the reflector.</i>
	The ultimate responsibility for safety rests with the facility operator and the individuals who work on the system.

7.1. Warranty Information

Sea Tel Inc. supports its Series 97, 00, 06 and 07 systems with a **ONE YEAR** warranty on parts and labor.

What's Covered by the Limited Warranty?

The Sea Tel Limited Warranty is applicable for parts and labor coverage to the complete antenna system, including all above-decks equipment (radome, pedestal, antenna, motors, electronics, wiring, etc.) and the Antenna Control Unit (ACU).

What's **NOT** Covered by the Limited Warranty?

It does **not** include Transmit & Receive RF Equipment, Modems, Multiplexers or other distribution equipment, whether or not supplied by Sea Tel commonly used in Satellite Communications (TXRX) Systems. These equipments are covered by the applicable warranties of the respective manufacturers.

Factory refurbished components used to replace systems parts under this warranty are covered by this same warranty as the original equipment for the balance of the original warranty term, or ninety (90) days from the date of replacement, whichever occurs last. Original Installation of the Series 97 system must be accomplished by or under the supervision of an authorized Sea Tel dealer for the Sea Tel Limited Warranty to be valid and in force.

Should technical assistance be required to repair your system, the first contact should be to the agent/dealer you purchased the equipment from.

Please refer to the complete warranty information included with your system.

7.2. Recommended Preventive Maintenance

Ensure that all of the normal operating settings (LAT, LON, HDG, SAT and al of the Tracking Receiver settings) are set correctly. Refer to the Functional Testing section to test the system.

7.2.1. Check ACU Parameters

Assure that the parameters are set correctly (you may wish to record them in the Factory Default Settings, in section 5 of this manual).

7.2.2. Latitude/Longitude Auto-Update check

Refer to the Latitude & Longitude Update check procedure in the Functional Testing section of this manual.

7.2.3. Heading Following

Refer to the Heading Following verification procedure in the Functional Testing section of this manual.

7.2.4. Azimuth & Elevation Drive

Refer to the Azimuth & Elevation Drive check procedure in the Functional Testing section of this manual.

7.2.5. Test Tracking

The 4 Quadrant Tracking Test is one of the best tests that can be performed on any Sea Tel 3-axis antenna. It verifies good antenna operation including antenna drive, ACU receiver operation, and tracking operation. This procedure explains the process of and is HIGHLY RECOMMENDED that this test is performed on ALL antennas that you work on.

Step 1: Ensure tracking receiver parameters are set correctly and that system is on satellite with peak signal (AGC above threshold).

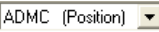
Step 2: Open up the  **ADMC** graph, and select to view Azimuth, Elevation, Relative and Signal trace lines.

Step 3: Press the  icon to center the displayed trace lines to the red reference line(s).

Step 4: Ensure tracking LED is off – If not press the  **TRACK** key to toggle tracking off

Step 5: Drive Azimuth down until displayed AGC drops approx. 2-3 dB (Do not drive antenna so far that AGC falls below threshold)

5-1 Press the  **NEXT** arrow key until Antenna window is displayed

5-2 Press and hold the  **RIGHT** arrow key until the displayed signal trace (AGC) falls approx. 2-3 divisions.)

Step 6: Re-enable tracking and verify proper recovery.

6-1 Press the  **TRACK** key to re-enable tracking.

6-2 Monitor the Trace lines for the next 30 seconds.

6-3 Verify Positional Trace and signal trace lines return to Red Reference line.

6-4 Verify the amount of time it took for tracking to bring AGC back to peak is within the specifications

** Nominal time to get back to peak is 8-30 seconds You should also be able to observe the DishScan tracking decisions being carried out by ACU by viewing either a 2, 4, 6, or 8 in the bottom left-hand side of the Azimuth Sub-menu display screen. A normal displayed response would be opposite than that of the axis driven, i.e. for an antenna driven up (CW) is azimuth you would expect to see a majority of 4's being displayed indicating DishScan senses signal strength higher down in azimuth, therefore sending the Azimuth Down command to PCU.

A flashing '2' indicates an Elevation Down command



A flashing '8' indicates an Elevation Up command

A flashing '4' indicates an Azimuth Down (CCW) command

A flashing '6' indicates an Azimuth Up (CW) command

A flashing '0' indicates No antenna drive command

Step 7: Repeat steps 1-6 driving antenna the other 3 directions, (Replace Step 5-2 with below steps as each direction is tested)

- 7-1 Using the  **LEFT** arrow to drive antenna down (CCW) in Azimuth
- 7-2 Using the  **DOWN** arrow key to drive antenna down in Elevation
- 7-3 Using the  **UP** arrow key to drive antenna up in Elevation

7.2.6. Visual Inspection - Radome & Pedestal

Conduct a good, thorough, visual inspection of the radome and antenna pedestal. Visually inspect the inside surface of the radome top and of the antenna pedestal. Look for water or condensation, rust or corrosion, white fiberglass powder residue, loose wiring connections, loose hardware, loose or broken belts or any other signs of wear or damage.

1. Radome Inspection - All the radome flanges are properly sealed to prevent wind, saltwater spray and rain from being able to enter the radome. Re-seal any open ("leaky") areas with marine approved silicone sealant. If heavy condensation, or standing water, is found inside the radome, isolate and seal the leak, and then dry out the radome. Small (1/8 inch) holes may be drilled in the base pan of the radome to allow standing water to "weep" out.
2. Antenna Pedestal Inspection - The shock/vibration springs and/or wire rope Isolators should not be frayed, completely compressed, or otherwise damaged. The plated and painted parts should not be rusted or corroded. The harnesses should not be frayed and all the connectors should be properly fastened and tightened. All hardware should be tight (no loose assemblies or counter-weights). Replace, re-coat, repair and/or tighten as necessary.

7.2.7. Mechanical Checks

Turn the pedestal power supply OFF

1. Inspect inside of radome for signs that the dish or feed have been rubbing against the inside of the fiberglass radome.
2. Rotate the pedestal through its full range of azimuth motion. The antenna should rotate freely and easily with light finger pressure.
3. Rotate the pedestal through full range of elevation rotation. The antenna should rotate freely and easily with light finger pressure.
4. Rotate the pedestal through full range of cross-level rotation. The antenna should rotate freely and easily with light finger pressure.
5. Rotate the level cage through the full 90 degrees of rotation from CCW stop to CW stop. The level cage antenna should rotate freely and easily with light finger pressure. Attached cables should not cause the cage to spring back more that a few degrees from either stop when released.
6. Inspect all drive belts for wear (black dust on/under the area of the belt).
7. Inspect AZ Drive chain. IF chain is beginning to show signs of rust or corrosion, apply a **light** coat of light duty oil to the chain. Wipe excess oil off to leave a light coating on the chain. **DO NOT over-lubricate.**

7.2.8. Check Balance

Check the balance of the antenna, re-balance as needed (refer to the Balancing the Antenna procedure below).

7.2.9. Observe Antenna Initialization

Observe the Antenna Initialization as described in the Troubleshooting section below.

7.3. Troubleshooting

7.3.1. Theory Of Stabilization Operation

The antenna system is mounted on a three axis stabilization assembly that provides free motion with 3 degrees of freedom. This assembly allows the inertia of the antenna system to hold the antenna pointed motionless in inertial space while the ship rolls, pitches and yaws beneath the assembly. Three low friction torque motors attached to each of the three free axes of the assembly provide the required force to overcome the disturbing torque imposed on the antenna system by cable restraints, bearing friction and small

air currents within the radome. These motors are also used to re-position the antenna in azimuth and elevation.

The Pedestal Control Unit (PCU) uses inputs from the level cage sensors to calculate the amount of torque required in each axis to keep the antenna pointed within +/-0.2 degrees. The primary sensor input for each loop is the rate sensor mounted in the Level Cage Assembly. This sensor reports all motion of the antenna to the PCU. The PCU immediately responds by applying a torque in the opposite direction to the disturbance to bring the antenna back to its desired position. Both the instantaneous output of the rate sensor (Velocity Error) and the integrated output of the rate sensor (Position Error) are used to achieve the high pointing accuracy specification.

The calculated torque commands are converted to a 5 volt differential analog signal by a Digital to Analog converter (D/A) and sent to each of three Brush-Less Servo Amplifiers. These amplifiers provide the proper drive polarities and commutation required to operate the Brush-Less DC Servo Motors in torque mode. The Torque acting on the mass of the antenna cause it to move, restoring the rate sensors to their original position, and closing the control loop.

Since the rate sensors only monitor motion and not absolute position, a second input is required in each axis as a long term reference to keep the antenna from slowly drifting in position. The Level and Cross Level reference is provided by a two axis tilt sensor in the level cage assembly. The Azimuth reference is provided by combining the ships gyro compass input and the antenna relative position.

7.3.2. Antenna Initialization (Series 97B & Series 00)

Turn the pedestal power supply ON. The brakes on the Elevation and Cross-Level motors will release.. Brake release power supply control circuit supplies 24 VDC to the brakes initially (5-10 seconds) and then reduces the voltage to 12VDC. The PCU will initialize the stabilized portion of the mass to be level with the horizon and at a prescribed Azimuth and Elevation angles. The antenna will go through the specific sequence of steps (listed below) to initialize the level cage, elevation, cross-level and azimuth to predetermined starting positions.

Initialization is completed in the following phases, each phase must complete properly for the antenna to operate properly (post-initialization). Observe the Initialization of the antenna pedestal.

Step 2. The level platform motor drives the Level Cage CW, issuing extra steps to assure that the cage is all the way to the mechanical stop. Then the Level Cage will be driven exactly 45.0 degrees CCW.

Step 3. Elevation axis then activates - Input from the LV axis of the tilt sensor is used to drive the Elevation of the equipment frame to bring the tilt sensor LV axis to level. This step takes approximately 10 seconds and will result in the dish being at 45.0 degrees in elevation. The level cage may still be tilted left or right at this time.

Step 4. Cross-Level axis activates - Input from the CL axis of the tilt sensor is used to drive Cross-Level of the equipment frame to bring the cross-level axis of the tilt sensor to level (this results in the tilt of the Cross-Level Beam being level). This step takes approximately 10 seconds.

Step 5. Azimuth axis activates - Antenna drives CW in azimuth until the "Home Flag" signal is produced. This signal is produced by a Home Switch hitting a cam (or by a Hall Effect sensor in close proximity to a Magnet). After another 10 second wait, the antenna will report its version number at the Antenna Control Unit (ACU).

This completes the phases of initialization. At this time the antenna elevation should 45.0 degrees and Relative azimuth should be at home flag (home switch engaged on the home flag cam).

If any of these steps fail, or the ACU reports model "xx97", re-configure the PCU as described in the this chapter. If initialization still fails, this indicates a drive or sensor problem, refer to the Troubleshooting section.

7.3.3. Troubleshooting using DacRemP

While troubleshooting a Sea Tel 3-Axis Antenna System, you must classify the fault you are dealing with as a failure within one of 3 major system functions, Targeting, Stabilization, and Tracking. Should there be a failure with any one of these functions, your system will not operate properly. A few simple checks may help determine which fault (if any) that you are dealing with. The matrix below lists some test(s) and which of the DacRemP graph selection would be best to use to identify a fault. The end of this chapter contains examples on how to use DacRemP to diagnose a fault.

Targeting: is the ability to accurately point the antenna to an angular position in free space and is controlled by the ACU. (Does the system drive to the Azimuth, Elevation, and Polarity positions within 1 degree of the desired satellite?)

Stabilization: is the process of de-coupling the ships motion from the antenna and is controlled by the PCU. (Does the system maintain the satellite link after turning off TRACKING?)

Tracking: is the process of issuing fine adjustments to the **pointing** angle of the antenna to optimize the received signal level and is controlled by the ACU. (Does the system pass a four quadrant-tracking test?)

Functional Test(s)	DacRemP Graph Selection to use	System Function(s)
Four Quadrant Tracking.	ADMC (Position)	Tracking
Azimuth Encoder Verification.	ADMC (Position)	Targeting
Sea Trial	ADMC (Position)	Targeting Tracking Stabilization
Side Lobe Plots	ADMC (Position)	Tracking
Targeting Alignment (AZ & EL Trims)	ADMC (Position)	Targeting
Determine Blockage Mapping	ADMC (Position)	Tracking
Unwrap recovery (Limited Az systems only)	ADMC (Position)	Stabilization
Pedestal Gain Verification	DISPIVC (Loop Error)	Stabilization
Home switch (flag) verification (Unlimited Az systems only)	DISPV (Ref)	Stabilization
Remote Tilt Verification	DISPV (Ref)	Targeting Stabilization
Level cage alignment Verification (sensor alignment)	DISPV (Ref)	Targeting Stabilization
Rate Sensor Output Verification	DISPW (Rate)	Stabilization
Level and CL fine balance Verification	DISPTC (Drive)	Stabilization
AZ Friction Torque Test	DISPTC (Drive)	Stabilization
DishScan Drive/Phase	DishScan XY	Tracking Stabilization

7.3.4. Antenna Loop Error Monitoring

The DacRemP **DISPIVC** graph chart provides a means for monitoring the accumulated velocity errors of the antenna for diagnostic purposes. If this error is excessive, it indicates external forces are acting on the antenna. These forces may be the result of but not restricted to static imbalance, excessive bearing friction, cable binding, or wind loading. If these forces cause the antenna to mis-point by more than 0.5° from the desired position the PCU will flag a “Stab Limit” error.

- To view the position error, select the graph chart.



- This chart displays sensed axis errors via three traces, CL (Cross Level), LV (Elevation), and AZ (Azimuth), at a fixed 0.05°/ vertical division.
- The normal trace average will plots it's display ± 3 divisions from the red reference line. Any trace line average plotted above this is of concern and troubleshooting required. The example below shows the forces exerted onto the antenna as a resultant of DishScan Drive. The example below shows the results of various forces put upon antenna.

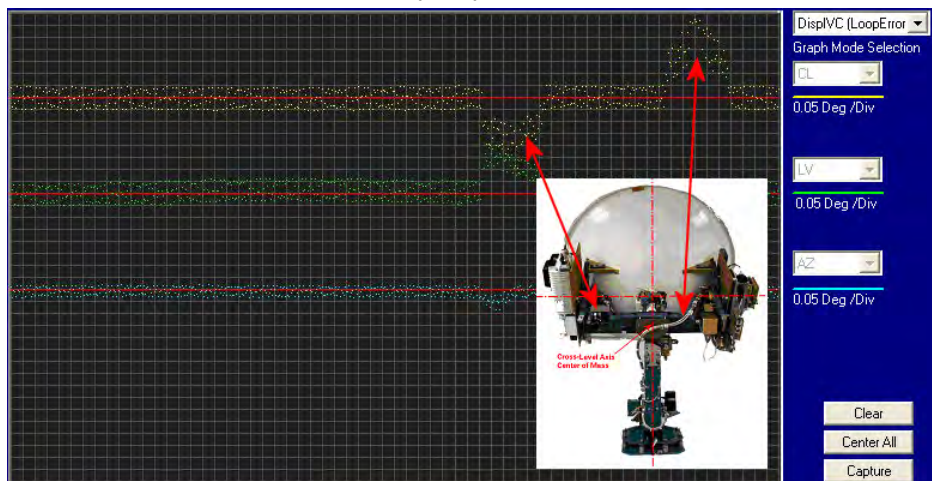

- Cross-Level Axis physically moved CCW (down to the left.) and then CW (up to the right.)
- Elevation Axis physically moved CW. (reflector slightly pushed up) and then physically moved CCW. (reflector slightly pushed down.) At the end of chart recording shows

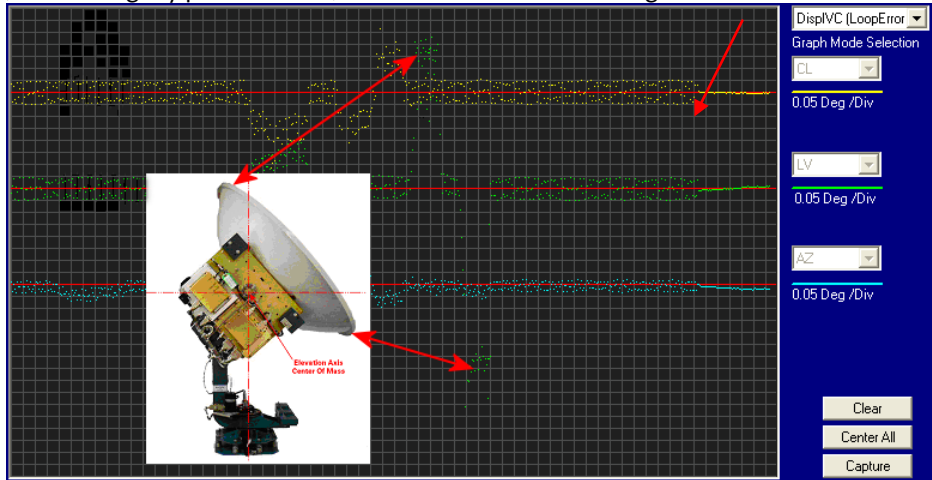

DishScan Drive turned Off, notice the lack of accumulated IVC errors.

7.3.5. Reference Sensor Monitoring

The DacRemP **DISPV** graph chart provides a means for monitoring the output of the 2 Axis Tilt Sensor and the Home Switch sensor for diagnostic purposes. The Tilt sensor (located inside the Level Cage Assembly) is the primary input for the antenna’s reference to the horizon (0° Elevation and 90° Cross-Level). While the Home Switch Sensor (located at the antenna base) is used to calibrate the antenna’s position relative to the vessels BOW.

- To view the reference sensors, select the **Disp V (Ref)** graph chart.
- This chart displays the output of the Tilt Sensor via two traces, CL (Cross Level), LV (Elevation) at a fixed 1°/ vertical division, and the home flag logic level via a single trace, AZ (Azimuth).



- The normal trace display for the Tilt Sensor, after performing remote tilt calibration, will be ± 4 divisions from the red reference line. Any trace line average plotted above this is of concern and troubleshooting required. See below for a screen capture of an antenna that is Level in both the Cross-Level and Elevation Axis.

The Cross Level Tilt display should plot on the red reference line when the level cage is level, referenced to the horizon. It should decrease (plots below red line) when the antenna is tilted to the left and increase (plots above red line) when tilted to the right. See below for a screen capture of an abnormal CL trace Plot, it is an indication that the antenna that is either listed to the right approx. 4 degrees or the PCU requires to much CL tilt bias.

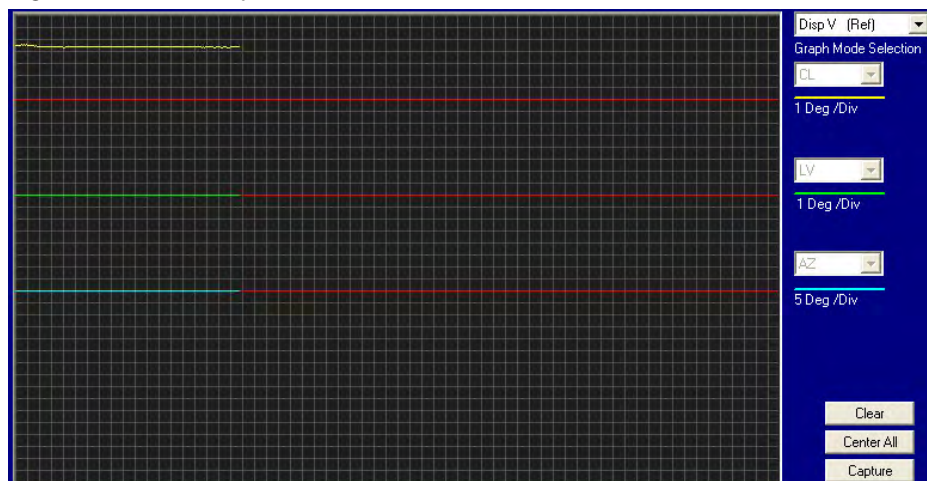

- The Level tilt display should plot on the red reference line when the level cage is level, referenced to the horizon. It should decrease (plots below red line) when the antenna is tilted forward (EL down) and increase (plots above red line) when tilted back (EL up).

- The Azimuth display for the Home Switch will normally display a logic level high (plots directly on Red reference line after clicking on the **Center All** button) when the home flag is NOT engaged and changing to a logic level low when engaged. See below for a screen capture of an antenna that was driven so that the Home Flag switch is engaged.



7.3.6. Open Loop Rate Sensor Monitoring

The DacRemP **DISPW** graph chart provides a means for monitoring the output of the 3 solid state rate sensors (located inside the Level Cage Assembly) for diagnostic purposes. The rate sensors are the primary inputs to the PCU for stabilization.

- To monitor the rate sensors, select the **Disp W (Rate)** graph chart
- This chart displays sensed output from the 3 rate sensors via three traces, CL (Cross Level), LV (Elevation), and AZ (Azimuth), at a fixed 1°/Second/vertical division.
- A normal trace display will be ± 1 divisions from the red reference line. The example shown below shows an antenna that is NOT currently sensing motion in any axis.

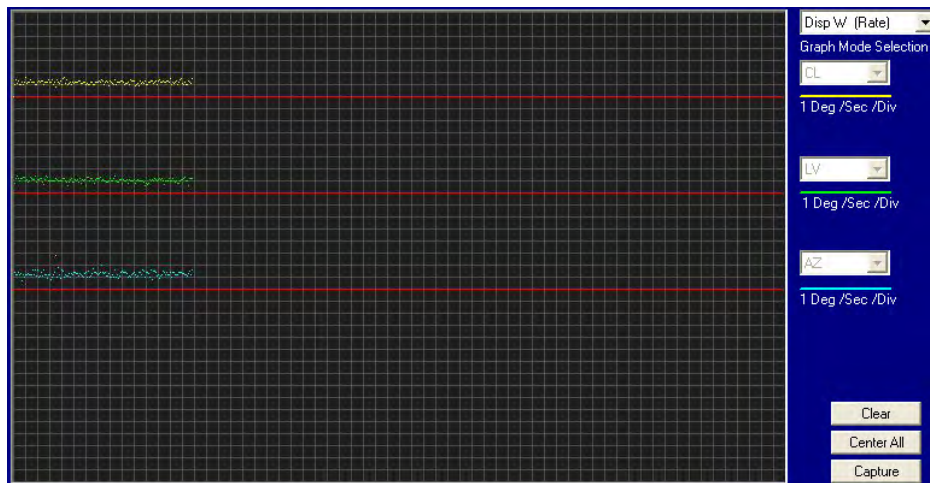

- The Cross Level display should decrease (plots below red line) as the antenna is tilted to the left and increase (plots above red line) as the antenna tilted to the right.
- The Level display should decrease (plots below red line) as the antenna is tilted forward and increase (plots above red line) as the antenna is tilted back.
- The Azimuth display should decrease (plots below red line) as the antenna is rotated CCW and increase (plots above red line) as the antenna is rotated CW. In the example below, the output of the Azimuth rate sensor is plotted above the reference line, indicating that the antenna was driven CW in Azimuth. Due to the in-practicality of driving an axis at a consistent rate, verification of rate

sensor output is, for the most part restricted to a positive or negative response of the Level Cage movement (plotting above or below the red reference line of each axis).



7.3.7. Open Loop Motor Test

The DacRemP **Comm Diagnostics** Window provides a means to enter in Remote Commands for driving each individual torque motor to test that motors functionality. By driving each axis and observing the resulting motion of the antenna, a coarse operational status of the motor and motor driver may be established.

- To manually drive the motors, select the “**Comm Diagnostics**” window under to the Tools submenu or Press “CTRL + C”
- Using the small field in the upper left hand corner of the window, type in the remote command and verify the motor appropriately drives in the direction commanded.
- To drive the Cross Level motor, key in ^1064, ^1128 or ^1192 and press **ENTER** to drive the Cross Level axis LEFT, OFF or RIGHT respectively.
- To drive the Level motor, key in ^2064, ^2128 or ^2192 and press **ENTER** to drive the level axis FORWARD, OFF or BACKWARD respectively.
- To drive the Azimuth motor, key in ^3064, ^3128 or ^3192 and press **ENTER** to drive the azimuth axis CW, OFF or CCW.

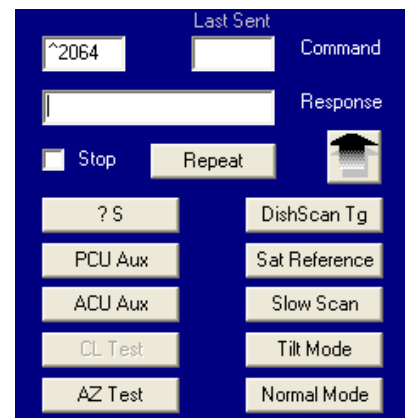

7.3.8. To Disable/Enable DishScan

To be able to use Step Track, or to revert to Conscan, as your active tracking mode you will have to disable DishScan.

Select the **DISHSCAN** parameter window on the ACU:

1. Press the RIGHT arrow, then press the UP arrow and last press the ENTER key to turn DishScan mode ON.
2. Press the RIGHT arrow, then press the DOWN arrow and last press the ENTER key to turn DishScan Mode OFF.

If you change this remote parameter, you must save the change using REMOTE PARAMETERS.

If DishScan is **OFF** and the **Step Integral** parameter is set to **0000**, you will get a **constant ERROR 0016** (DishScan error) and you will see **zeros** flashing in the lower left of the Azimuth and Elevation ENTRY menu displays. This is a visual indication that DishScan is turned OFF.

7.3.9. Satellite Reference Mode

The ships gyro compass input to the ACU may be accurate and stable in static conditions and yet may NOT be accurate or stable enough in some underway dynamic conditions. If there is no gyro compass or if the input is corrupt, not stable or not consistently accurate the tracking errors will become large enough to cause the antenna to be mis-pointed off satellite.

Satellite Reference Mode will uncouple the gyro reference from the azimuth rate sensor control loop. This decoupling of the Gyro source only happens 5 minutes after an azimuth command has been sent to the antenna by means of an AZ target command, a search pattern initiated, or the a Satellites longitudinal position is targeted. When operating in Satellite Reference Mode changes in ships gyro reading will reflect its changes to the ACU's display but will not directly affect the azimuth control loop. The Pedestal Control Unit will stabilize the antenna based entirely on the azimuth rate sensor loop and the tracking information from DishScan. This will keep the azimuth rate sensor position from eventually drifting away at a rate faster than the tracking loop can correct by using the tracking errors to regulate the rate sensor bias.

Satellite Reference Mode can be used as a diagnostic mode to determine if tracking errors are caused by faulty gyro inputs.

Satellite Reference Mode **MUST be used when:**

- No Gyro Compass is available
- Frequent or constant ACU Error Code 0001 (Gyro Compass has failed)
- Gyro Compass output is NMEA heading
- Flux Gate Compass is being used
- GPS Satellite Compass is being used

To view, or change, the Satellite Reference Mode status, select the SAT REF remote parameter:

1. Press the RIGHT arrow, then press the UP arrow and last press the ENTER key to turn Satellite Reference Mode ON.
2. Press the RIGHT arrow, then press the DOWN arrow and last press the ENTER key to turn Satellite Reference Mode OFF.

If you change this remote parameter, you must save the change using REMOTE PARAMETERS.

7.3.10. To Read/Decode an ACU Error Code 0008 (Pedestal Function Error):

An Error Code 8 as reported by the ACU is an indication that the above decks equipment has experienced an error. One of the functions available within the “Comm Diagnostics” tool window provides the means to read and decode the actual discreet Pedestal Function Error.

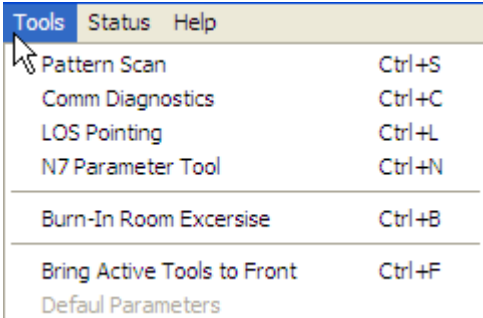
Select the “Comm Diagnostics” window under to the Tools submenu or Press “CTRL + C”	 <table border="1" style="width: 100%; border-collapse: collapse;"> <tr> <td style="background-color: #e0e0e0;">Tools</td> <td style="background-color: #e0e0e0;">Status</td> <td style="background-color: #e0e0e0;">Help</td> </tr> <tr> <td>Pattern Scan</td> <td></td> <td>Ctrl+S</td> </tr> <tr> <td>Comm Diagnostics</td> <td></td> <td>Ctrl+C</td> </tr> <tr> <td>LOS Pointing</td> <td></td> <td>Ctrl+L</td> </tr> <tr> <td>N7 Parameter Tool</td> <td></td> <td>Ctrl+N</td> </tr> <tr> <td colspan="3" style="border-top: 1px solid black;">Burn-In Room Exercise</td> </tr> <tr> <td></td> <td></td> <td>Ctrl+B</td> </tr> <tr> <td colspan="3" style="border-top: 1px solid black;">Bring Active Tools to Front</td> </tr> <tr> <td></td> <td></td> <td>Ctrl+F</td> </tr> <tr> <td colspan="3">Default Parameters</td> </tr> </table>	Tools	Status	Help	Pattern Scan		Ctrl+S	Comm Diagnostics		Ctrl+C	LOS Pointing		Ctrl+L	N7 Parameter Tool		Ctrl+N	Burn-In Room Exercise					Ctrl+B	Bring Active Tools to Front					Ctrl+F	Default Parameters		
Tools	Status	Help																													
Pattern Scan		Ctrl+S																													
Comm Diagnostics		Ctrl+C																													
LOS Pointing		Ctrl+L																													
N7 Parameter Tool		Ctrl+N																													
Burn-In Room Exercise																															
		Ctrl+B																													
Bring Active Tools to Front																															
		Ctrl+F																													
Default Parameters																															

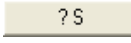
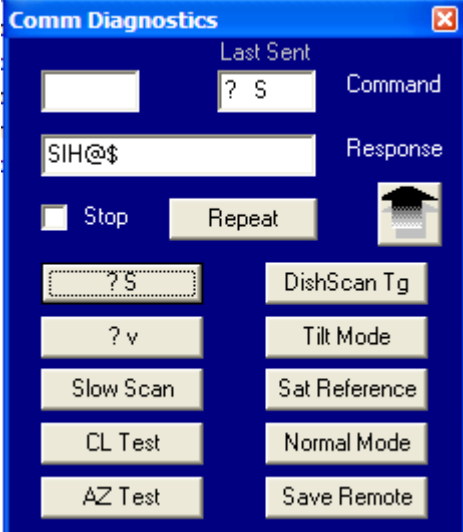
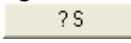
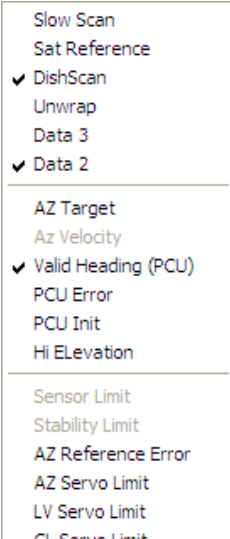
<p>Left mouse click on the  icon.</p>	
<p>Right mouse click on the  icon.</p> <p>This will display a list box with the status of the above decks pedestal filtered into 3 sections. Items preceded with a check marks indicate a flagged status. See matrix below for further information on each state.</p>	

State	Description
<i>PCU Status (Word 1)</i>	
Slow Scan	Indicates antenna is in a specialized mode, Slow Scan, which is required when ever a test requires driving the antenna >5°/sec
Sat Reference	Indicates that satellite reference mode is enabled.
DishScan	Indicates that DishScan Drive is enabled.
Unwrap	Indicates that the antenna is currently in an “Unwrap” state. This is not a valid error for unlimited azimuth antenna systems
Data 3	Indicates active communication between above decks and below decks equipment at the time of query
Data 2	Indicates active communication between above decks and below decks equipment at the time of query

PCU Status (Word 2)	
Az Target	Indicates the antenna is currently targeting a pre-determined azimuth position
Az Velocity	**Not a valid state**
Valid Heading (PCU)	Indicates that the PCU has received and integrated the heading value from the ACU into the Azimuth Stabilization Loop. This is NOT an indication of a proper Heading integration into ACU.
PCU Error	Indicates that one or more errors have been reported by the above decks equipment.
PCU Init	Indicates that the above decks equipment is currently performing an Initialization sequence
Hi Elevation	Indicates that the above decks equipment is operating an Elevation Position higher than 83°
PCU Error Status (Word 3)	
Sensor Limit	**Not a valid state**
Stability Limit	Indicates that the above decks equipment is mis-pointed from its intended target by more than 0.5°. (FCC Tx Mute Compliance)
AZ Reference Error	Indicates a failure to integrate one the reference inputs within the Azimuth Stabilization Loop.
AZ Servo Limit	Indicates the current draw through the Azimuth Servo Amplifier (motor driver PCB) has exceeded what is required during normal operation
LV Servo Limit	Indicates the current draw through the Elevation Servo Amplifier (motor driver PCB) has exceeded what is required during normal operation
CL Servo Limit	Indicates the current draw through the Cross-Level Servo Amplifier (motor driver PCB) has exceeded what is required during normal operation

7.3.11. Remote GPS LAT/LON Position:

The above decks equipment has an integrated on board Furuno GPS antenna system. The Latitude and Longitude position information provided are utilized to calculate the Azimuth, Elevation, Cross-level and Polarity pointing angles of the desired satellite. The DacRemP **“Comm Diagnostics”** Window provides a means to query the GPS antenna to verify proper operation. The procedure below describes this process.

<p>1. Select the “Comm Diagnostics” window under to the Tools submenu or Press “CTRL + C”</p>	
---	--

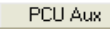
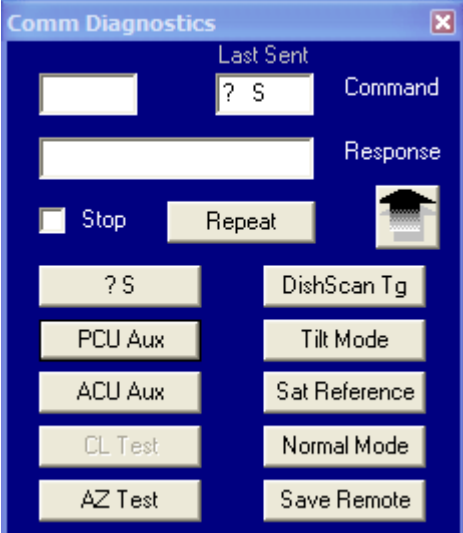
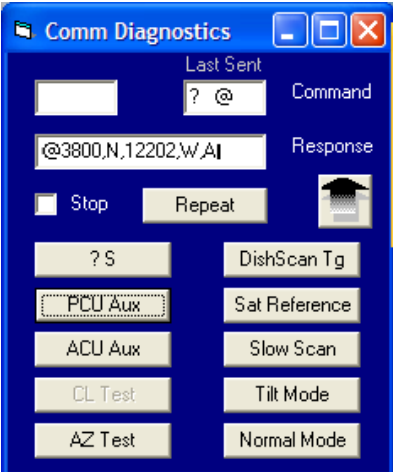
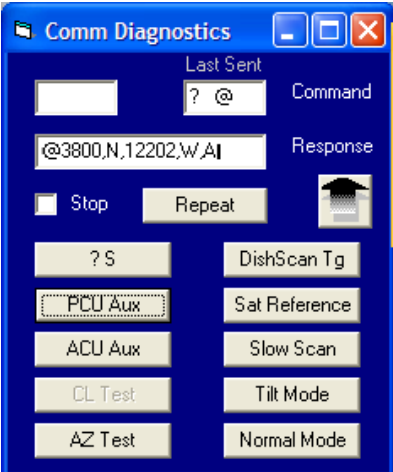
<p>Left mouse click on the  icon.</p>	
<p>Left Mouse click on the “?@ PCU GPS position, 1 min (1 Nm)”</p>	
<p>In the “Response” window verify proper GPS position to within 1 nautical mile of your current position. The Latitude & Longitude position of the GPS will be displayed in the following format: “@ LAT,N,LON,E,A” Where LAT and LON are in degrees and minutes, LAT will be followed by N or S (North or South), LON will be followed by E or W (East or West), then a status character and finally a checksum character.</p>	
<p>Furuno default value is in Japan at 34.4N 135.2E (@3444,N,13521,E,,_). After acquiring a good fix at Sea Tel the string is @3800,N,12202,W,A^ for our 38N 122W Latitude and Longitude position. The status character tells you the status of the GPS.</p>	

“,” (Comma) = GPS has NOT acquired a proper fix, “N” = GPS fix is NOT valid “A” = GPS has acquired a valid fix.	
---	--

7.4. Maintenance

7.4.1. Balancing the Antenna

The antenna and equipment frame are balanced at the factory however, after disassembly for shipping or maintenance, balance adjustment may be necessary. The elevation and cross-level motors have a brake mechanism built into them, therefore, **power** must be ON to release the brakes and **antenna drive** must be OFF to balance the antenna. . **Do NOT remove any of the drive belts.** Balancing is accomplished by adding or removing balance trim weights at strategic locations to keep the antenna from falling forward/backward or side to side. The antenna system is not pendulous so 'balanced' is defined as the antenna remaining at rest when left in any position. The antenna should be balanced within one ounce at the typical trim weight location of 10 inches from the axis of rotation.

1. Turn Antenna power breaker ON
2. To turn OFF antenna drive (AZ, EL & CL) follow the Pedestal Control Unit Configuration procedure in this chapter to set the PCU configuration to (N0000) but do NOT save.
3. Balance the antenna elevation axis with the elevation near horizon (referred to as front to back balance) **by adding, or subtracting, small counter-weights.**
4. Then balance Cross Level axis (referred to as left-right balance) **by moving existing counter-weights.** Do NOT add counter-weight during this step.
5. Last, balance the Elevation Axis with the antenna pointed at zenith (referred to as top to bottom balance) **by moving existing counter-weights.** Do NOT add counter-weight during this step.
6. When completed, the antenna will stay at any position it is pointed in for at least 5 minutes (with little, to no, ship motion).
7. Turn antenna power OFF, and then back ON, to re-Initialize the antenna. This will also turn antenna drive (AZ, EL & CL) back ON.

7.4.2. Polang Alignment

If the polarization motor or pot have been replaced, use this procedure to realign the feed assembly and potentiometer.

1. Verify the following ACU default setup parameters are set to: POL SCALE set to 90, POL OFFSET set to 40 and TX POLARITY is set to 2
2. Select the POL TYPE parameter under the MODE/SETUP display and change the polarity type setting to 0009. Press **ENTER** several times to select the TX POLARITY and assure that it is set to 0002. Press **NEXT** key to select the ANTENNA display. Press **ENTER** key to select the POLARITY Sub-menu display.
3. Rotate the feed using the **UP** and **DOWN** keys so that the feed is in the CENTER of its range and the ports are aligned Horizontal and Vertical (Align the metal patches horizontally and vertically on an HCDC feed with the Ku band LNB at 2 o'clock). This is the Center Reference position.
4. Set adjustment of the potentiometer on the feed for an initial reading of 130+/-5 counts on the ACU. Note this display reading as the Center Reference value
5. Press the **UP** arrow key. Verify the feed rotates CW to 220 without obstruction.
6. Press the **DOWN** arrow key. Verify the feed rotates CCW to 45 without obstruction.
7. From center of range (POL count 130) rotate the feed CW 90 degrees viewed looking towards the satellite (CCW looking into the dish) by pressing the **UP** key. The display reading must have INCREASED. Record the change in the POL display reading from the Center Reference value. The change must be 90. If it is any other value, there is a problem with the Polang potentiometer scale settings and should be corrected for proper operation.

- Rotate the feed CCW 180 degrees or as far as it will travel, viewed looking towards the satellite (CW looking into the dish). If the feed allows full 180-degree rotation, the POL display will show 90 counts below the center reference value.

NOTE: If the feed does not allow a full 180 degree rotation to the CCW position, (CW looking into the dish), move the feed as far as it will go and readjust the Polang potentiometer setting so the POL display shows 30-32. Move the feed to the center position and note the new reading. Calculate the POL OFFSET as the Center minus POL SCALE value and enter in the ACU parameter list.

- Select the POL TYPE parameter again and change the POL TYPE to 72 (64+8) to enable auto pol. If the POL position is not optimum using auto pol, trim the POL position up or down by adjusting the POL OFFSET parameter.

Polang Operation and Alignment

- Set the POLANG for auto operation (POLANG TYPE = 72). Enter your longitude into SAT menu
- Verify the system returns the feed to TX Port Horizontal Polarity.
- Turn DishScan ON (Comm Diagnostic's window (CTRL+F) and click DishScan "Tg")
- Select REMOTE PARAMETERS and press ► arrow key and then Enter key to save
- Turn Tracking OFF. Set POLANG for manual operation (SETUP menu: POLANG TYPE = 9)
- Determine optimize polarization by manually adjusting POLANG for the maximum tracking signal level on the spectrum analyzer or ACU AGC or under guidance of the NOC during a Cross-Pol isolation test.







To Optimized polarization, refer to setup chapter of this manual.

7.4.3. To Adjust Tilt:

A REMOTE TILT calibration is required to align the level cage assembly correctly so that all sensors will be aligned accurately to the axis they relate to. The fluid filled tilt sensor provides a two dimensional horizon reference. The system is not able to automatically calculate the exact center value, therefore it is necessary to perform this procedure to manually enter any offset required to make sure the PCU receives a true reference to the horizon. The procedures below describes the process of performing this calibration from either the ACU front panel or DacRemP diagnostic software by connecting the ACU's RS-422 M&C Port to an available serial port on a Laptop/Desktop computer using a standard 9 pin serial cable.

Step 1 Turn Off DishScan Drive.

Using the DAC2202 ACU Front Panel:

- Go to Remote Command window by pressing and holding the two **LEFT & RIGHT** arrows  until the EL TRIM parameter is displayed.
- Press and release both **Left & Right** arrow keys again. The "SAVE NEW PARAMETERS" window should now be displayed.
- Press either the  **ENTER** key or the  **DOWN** key until the "REMOTE DishScan TG" parameter is displayed.
- Press the  **"RIGHT** arrow to activate selection, then press the  Up arrow to toggle state to OFF. Press the  **ENTER** key (Note: You will see that an error code 16 is generated when DishScan movement is off.)

Using DacRemP:

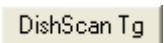
- Click on the  icon in the Comm Diagnostics window. (Verify that DishScan is turned off by clicking the Error LED on main display panel, there should be a check mark next to Conscan/DishScan)

(Steps 2-7 will require assistance to observe and operate antenna simultaneously)

Step 2: At Antenna, If not already installed, place a circular level bubble on top lid of level cage.

Step 3: On the ACU front Panel, press either the  **ENTER** key or the  **DOWN** arrow key until the **REMOTE TILT** window is displayed

Step 4: Push the  **RIGHT** arrow key to activate the Remote Tilt Mode.

Step 5: Based on the feedback from the technician observing the circular bubble, the technician which operating the ACU will need to use the arrow keys to rotate the stabilized antenna mass from front to back and left to right. You should wait at least 10 seconds between commands to allow time for sensor to settle.

 Left arrow will rotate antenna mass down to the left in the Cross-Level axis 1/2 degree

 **Right** arrow will rotate antenna mass up to the right in the Cross-Level axis 1/2 degree

 Up arrow will rotate antenna mass up in the Level axis 1/2 degree

 **Down** arrow will rotate antenna mass down in the Level axis 1/2 degree

When correct the Bubble should be as close to the center of the fluid as possible.



Step 6: Press  **ENTER** key to exit Remote Tilt Mode.

Step 7: Verify Tilt Bias entered is within specifications.

From antenna:



2. Observe the bubble for approximately 3-5 minutes to ensure it remains centered.

Using DacRemP:

3. Select the reference sensor graph.
4. Verify the CL and LV displays are steady and within 4 divisions of nominal. (Anything more than 4 divisions above or below red reference line should be of concern and troubleshooting is required)

Step 8: Save Level and Cross-Level Tilt Bias values.

Using the DAC2202 ACU Front Panel:

5. Press  **DOWN** arrow or enter until you see “**REMOTE PARAMETERS**” window is displayed
6. Press  **RIGHT** arrow and then press  **ENTER** key (you will see a confirmation saying ‘SAVED’)

Using DacRemP:

7. Click icon on the Remote Command window. (Verify ^0087 is displayed in the “Last Sent Command” window)

This saves the new tilt bias settings in the PCU. Reset or re-initialize the antenna to verify that the Level cage is properly level with the new settings.

7.4.4. To Reset/Reinitialize the Antenna:

Pressing Reset on the ACU front panel does NOT cause a reset of the above decks equipment. To Re-initialize the antenna from the **REMOTE COMMAND** window on the ACU:

1. Using the **LEFT/RIGHT** and **UP/DOWN** arrow keys set the Remote Command value to ""0090" and press **ENTER**.

This resets the PCU on the antenna. The antenna will reinitialize with this command (Performs a similar function as a power reset of the antenna).

7.5. Pedestal Control Unit Configuration - 9707

The PCU is designed to be used with a variety of antenna pedestal configurations. The configuration information that is unique to each pedestal type is stored in a Non Volatile Random Access Memory (NVRAM) in the PCU enclosure. If the PCU is replaced or the NVRAM in the PCU should become corrupt, the PCU must be re-configured to operate with the pedestal it is installed on. The default configuration for the PCU is model xx07. In this configuration the PCU will not drive any of the three torque motors (AZ, EL & CL) to prevent damage to the unknown pedestal.

Visually confirm the PCU software version to identify the correct system configuration number to use for your antenna. Press the RESET button on your ACU to display the Antenna Control Unit software version and then, about 10 seconds later, the PCU model and software version will be displayed.

To configure the PCU, select the REMOTE COMMAND window on the DAC-2200.

EXAMPLE: For an 9707 Model Antenna with PCU software version 2.00:

7.5.1. To configure the PCU:

1. Select the REMOTE COMMAND window on the ACU.
2. Refer to the table below to key in the appropriate value for you model antenna to enter in the next step. **EXAMPLE:** For a 9707 Model Antenna, select system type 0211.
3. Using the **LEFT/RIGHT** and **UP/DOWN** arrow keys set the Remote Command value to "N0211" and press **ENTER**. The display should now show "N0211".
4. Press **ENTER** several times to select **REMOTE PARAMETERS**. Press **LEFT** arrow and then **ENTER** to save the system type in the PCU.
5. Press **RESET** and the displayed Remote Version Number should now display "9707 VER 2.nn".

7.5.2. Balancing the Antenna

The antenna and equipment frame are balanced at the factory however, after disassembly for shipping or maintenance, balance adjustment may be necessary. The elevation and cross-level motors have a brake mechanism built into them, therefore, **power** must be ON to release the brakes and **DishScan and antenna drive** must be OFF to balance the antenna. **Do NOT remove any of the drive belts**. Balancing is accomplished by adding or removing balance trim weights at strategic locations to keep the antenna from falling forward/backward or side to side. The antenna system is not pendulous so 'balanced' is defined as the antenna remaining at rest when left in any position.

The "REMOTE BALANCE" parameter (located at the end of the Remote Parameters after REMOTE TILT) of the ACU. When enabled, Remote Balance Mode temporarily turns DishScan, Azimuth, Elevation and Cross-Level drive OFF. This function is required when trying to balance antenna systems that have a built-in brakes on the elevation and cross-level motors.

Assure that Antenna power is ON and that the antenna has completed initialization.

At the ACU:

1. From the ACU - REMOTE BALANCE parameter: Enable balance mode (refer to your ACU manual). The screen should now display "REMOTE BALANCE ON".

At the Antenna:

1. At the Antenna: Balance the antenna with the elevation near horizon (referred to as front to back balance) **by adding, or subtracting, small counter-weights**.
2. Then balance Cross Level axis (referred to as left-right balance) **by moving existing counter-weights from the left to the right or from the right to the left**. Always move weight from one location on the equipment frame to the same location on the opposite side of the equipment frame (ie from the top left of the reflector mounting frame to the top right of the reflector mounting frame). Do NOT add counter-weight during this step.

3. Last, balance the antenna with the elevation pointed at, or near, zenith (referred to as top to bottom balance) **by moving existing counter-weights from the top to the bottom or from the bottom to the top.** Always move weight from one location on the equipment frame to the same location on the opposite side of the equipment frame (ie from the top left of the reflector mounting frame to the bottom left of the reflector mounting frame). Do NOT add counter-weight during this step.
4. When completed, the antenna will stay at any position it is pointed in for at least 5 minutes (with no ship motion).
5. **Do NOT cycle antenna power to re-Initialize the antenna.** Return to the ACU, which is still in REMOTE BALANCE mode, and press ENTER to exit Remote Balance Mode. When you exit Balance Mode the antenna will be re-initialized, which turns DishScan, Azimuth, Elevation and Cross-Level drive ON.

8. 9707D-70 Technical Specifications

The technical specifications for your Series 07 Above Decks Equipment subsystems are listed below: Refer to your ACU manual for its' Specifications.

8.1. Antenna Reflector

Type	Honeycomb Fiberglass Parabola
Diameter (D)	2.4 Meter Modified Offset
Sidelobe:	Compliant with Intelsat Standard G
Voltage Axial Ratio:	1.3:1, maximum, Receive Band 1.09:1, maximum, Transmit Band
Focal Length	38 in
f/D	0.245
RX Gain	38.5 dBi at 3.95 GHz 47.75 dBi at 11.85 GHz
TX Gain	41.7 dBi at 6.18 GHz 48.45 dBi at 14.25 GHz

8.2. Feed Assemblies

8.2.1. C-Band TXRX Feed Assembly

Type	Prime focus
Transmit frequency	5.9-6.4 GHz C Band
Receive frequency	3.7-4.2 GHz C Band
Polarization	Linear or Circular
VSWR :	1.3:1
Polang control	24 volt DC motor with position feedback for Linear Feed. None for Circular Feed
LNB/LNC Gain & Noise Figure	Refer to RF Equipment vendor manual(s)

8.3. RF Equipment

C-Band Block Up-Converter	Codan model 67xx, 20 or 40 Watt C-Band MBUC, Standard or Extended band with waveguide output
C-Band LNB	Norsat model 3000 C-Band PLL LNB
Noise Temperature	20K to 30K
Gain	55dB min to 70 dB max
Input Frequency Range	3.40-4.20 GHz
Local Oscillator Frequency	5.15 GHz (stability +/- 5kHz to +/- 25kHz depending on model)
Output Frequency Range	950-1750 MHz

8.4. **Stabilized Antenna Pedestal Assembly**

Type:	Three-axis (Level, Cross Level and Azimuth)
Stabilization:	Torque Mode Servo
Stab Accuracy:	0.2 degrees MAX, 0.1 degrees RMS in presence of specified ship motions (see below).
LV, CL, AZ motors:	Size 34 Brushless DC Servo.
Inertial Reference:	Solid State Rate Sensors
Gravity Reference:	Two Axis Fluid Tilt Sensor
AZ transducer:	256 line optical encoder / home switch
Range of Motion:	
Elevation	-15 to +100 degrees
Cross Level	+/- 25 degrees
Azimuth	Unlimited
Elevation Pointing:	+0 to +85 degrees (with 15 degree Roll) +5 to +80 degrees (with 20 degree Roll) +10 to +75 degrees (with 25 degree Roll)
Relative Azimuth Pointing	Unlimited
Specified Ship Motions (for stabilization accuracy tests):	
Roll:	+/- 15 degrees at 8-12 sec periods
Pitch:	+/- 10 degrees at 6-12 sec periods
Yaw:	+/- 8 degrees at 15 to 20 sec periods
Turning rate:	Up to 12 deg/sec and 15 deg/sec/sec
Headway:	Up to 50 knots
Mounting height:	Up to 150 feet.
Heave	0.5G
Surge	0.2G
Sway	0.2G
Maximum ship motion:	
Roll	+/- 25 degrees (Roll only) +/- 20 degrees (combined with Pitch)
Pitch	+/- 15 degrees
Yaw Rate	12 deg/sec, 15 deg/sec/sec

8.5. **Pedestal Control Unit (PCU)**

The PCU Assembly contains 1 Printed Circuit Board (PCB). It is the main control board.

Connectors	
Antenna Pedestal	44 Pin D-Sub connector
M&C Interface	15 Pin D-Sub connector
GPS Input	BNC connector
Controls	None
M&C Interface	9600 Baud RS-422

8.6. Unlimited Azimuth Modems (3 Channel) L-Band IF

Combined Signals	950-3000 MHz L-Band RX IF, 1.1/1.5, MHz FSK Pedestal M&C
Voltage Output	18VDC, 500mA MAX
Connectors:	
Rotary Joint	SMA Connector
L-Band RXIF	Type F
DC / Ped M&C	9 pin D-Sub Connector

8.7. 144" Radome Assembly

Type	Rigid dome
Material	Composite foam/fiberglass
Size	144" Diameter x 142" High
Base Hatch size	18" high x 34" wide
Side Door	18" wide x 36" high
Number of panels	Twelve panels (6 upper & 6 lower panels), one top cap and one base pan
Installed height:	164" including base frame if mounted with standard Legs, 148" if Flush-mounted
Installed weight	MAX 1800 LBS (including Antenna Pedestal Assembly)
RF attenuation	1.5 dB @ 6 GHz, dry 1.5 dB @ 12 GHz, dry 1.5 dB @ 14 GHz, dry
Wind:	Withstand relative average winds up to 100 MPH from any direction.
Ingress Protection Rating	All Sea Tel radomes have an IP rating of 56

NOTE: Radome panels can absorb up to 50% moisture by weight. Soaked panels will also have higher attenuation.

8.8. Environmental Conditions (ADE)

Temperature:	-20 degrees C to 55 degrees C.
Humidity:	Up to 100% @ 40 degrees C, Non-condensing.
Spray:	Resistant to water penetration sprayed from any direction.
Icing:	Survive ice loads of 4.5 pounds per square foot. Degraded RF performance will occur under icing conditions.
Rain:	Up to 4 inches per hour. Degraded RF performance may occur when the radome surface is wet.
Wind:	Withstand relative average winds up to 100 MPH from any direction.
Vibration:	Withstand externally imposed vibrations in all 3 axes, having displacement amplitudes as follows:
Frequency Range, Hz	Peak Single Amplitude
4 - 10	0.100 inches (0.1G to 1.0G)
10 - 15	0.030 inches (0.3G to 0.7G)
15 - 25	0.016 inches (0.4G to 1.0G)
25 - 33	0.009 inches (0.6G to 1.0G)
Corrosion	Parts are corrosion resistant or are treated to endure effects of salt air and salt spray. The equipment is specifically designed and manufactured for marine use.

8.9. TXRX System Cables

8.9.1. Antenna Control Cable (Provided from ACU-MUX)

RS-422 Pedestal Interface

Type	Shielded Twisted Pairs
Number of wires	
Wire Gauge	24 AWG or larger
Communications Parameters:	9600 Baud, 8 bits, No parity
Interface Protocol:	RS-422
Interface Connector:	DE-9P

8.9.2. Antenna Transmit & Receive IF Coax Cables (Customer Furnished)

Due to the dB losses across the length of the RF coaxes at L-Band, Sea Tel recommends the following 50 ohm coax cable types (and their equivalent conductor size) for our standard pedestal installations:

Run Length	Coax Type	Conductor Size
up to 35 ft	RG-58	20 AWG
up to 75 ft	RG-8 or LMR-300	18 AWG
up to 150 ft	RG-213, RG214 or LMR-400	14 AWG
up to 200 ft	LDF4-50 Heliax or LMR-500	10 AWG
Up to 300 ft	LMR-600	6 AWG

For runs longer than 300 feet, Sea Tel recommends Single-mode Fiber Optic Cables with Fiber Optic converters.

8.9.3. Multi-conductor Cables (Customer Furnished)

Due to the voltage losses across the multi-conductor cables, Sea Tel recommends the following wire gauge for the AC & DC multi-conductor cables used in our standard pedestal installations:

Run Length	Conductor Size
up to 50 ft	20 AWG (0.8 mm)
up to 100 ft	18 AWG (1.0 mm)
up to 150 ft	16 AWG (1.3 mm)
up to 250 ft	14 AWG (1.6 mm)
Up to 350 ft	12 AWG (2.0 mm)

8.9.4. AC Power Cable Above Decks (Customer Furnished)

Voltage:	110 or 220 volts AC, 50/60 Hz., single phase
Power:	100 Watts MAX , pedestal only

8.9.5. Gyro Compass Interface Cable (Customer Furnished)

Type:	Multi-conductor, Shielded
Number of wires	4 Conductors for Step-By-Step Gyro, 5 Conductors for Synchro
Wire Gauge:	see Multi-conductor Cables spec above
Insulation:	600 VAC

9. Drawings

The drawings listed below are provided as a part of this manual for use as diagnostic reference.

9.1. 9707D-70 Model Specific Drawings

Drawing	Title	
128390-1_B4	System, Model 9707D-70, C-Circular, A/C	9-7
125075-3_G	System Block Diagram – Model 9707D-70	9-9
128389-1_A	General Assembly – Model 9707D-70	9-12
125076_C1	Antenna System Schematic – Model 9707-70	9-14
123351_C	Modular Drop-In Tx/Rx Circular C-Band Feed Assembly	9-15
123908_B2	Installation Arrangement	9-17
111365-17_N1	144" Radome Assembly	9-19
123723-5_B1	Radome Base Assembly, with Internal or External A/C	9-21
122508_E	Air Conditioner Assembly, Internal	9-23
123496_C1	Air Cooled Environmental Unit, Internal	9-25

9.2. Series 07 General Drawings

Drawing	Title	
125497_B	Pedestal Harness Schematic – Model 9707D-70	9-26
121628-4_P	Terminal Mounting Strip	9-27
116881-18_C	Base MUX Rack Panel Assembly	9-29

This Page Intentionally Left Blank

SINGLE LEVEL MFG BILL OF MATERIAL

FIND	QTY	PART NO	REV	DESCRIPTION	REFERENCE DESIGNATOR
1	1 EA	128389-1	A	GENERAL ASS'Y, 9707D-70	
2	1 EA	111365-17	N1	RADOME ASS'Y, 144 INCH, WHITE/SIDE AC	
3	1 EA	123723-1	B1	RADOME BASE ASS'Y, 75 IN., STL, NO AC	
6	1 EA	124571-2		SSPB, C-BAND, CODAN MBUC, 25W, 6725-W	
11	1 EA	124556-3	A3	LNB, C-BAND PLL, NORSAT 3130F	
14	1 EA	125498-1	C	FEED ASS'Y, C-BAND, CIRCULAR, DISHSCA	
15	1 EA	125411-3	J	DAC-2202, SCPC RCVR, 9 WIRE IF	
16	1 EA	122384-26	C	BELOW DECK KIT, 9707, L-BAND IF, RX S	
17	1 EA	121934	B	WARRANTY PACKET, XX96/XX97	
18	2 EA	125935	A1	MANUAL CD, 9707-70	
20	1 EA	123013	F	SUPPORT DISK	
21	4 EA	114239	A	SIGN, WARNING MICROWAVE	
26	1 EA	122539-1	B	SHIP STOWAGE KIT, XX97	
27	1 EA	114569	D	BALANCE WEIGHT KIT	
28	1 EA	124877-1	C	DECAL KIT, XX97, SEATEL (126 IN/144 I	
31	1 EA	124796-002	A	CABLE ASS'Y, M&C, CODAN BUC, 2 METERS	

<h1 style="margin: 0;">Sea Tel</h1> <p style="margin: 0;"><i>COBHAM</i></p>				
<p>SYSTEM, 9707D-70, CIRC, 25W, 3130F</p>				
PROD FAMILY 9707	EFF. DATE 12/15/2009	SHT 1 OF 2	DRAWING NUMBER 128390-1	REV B

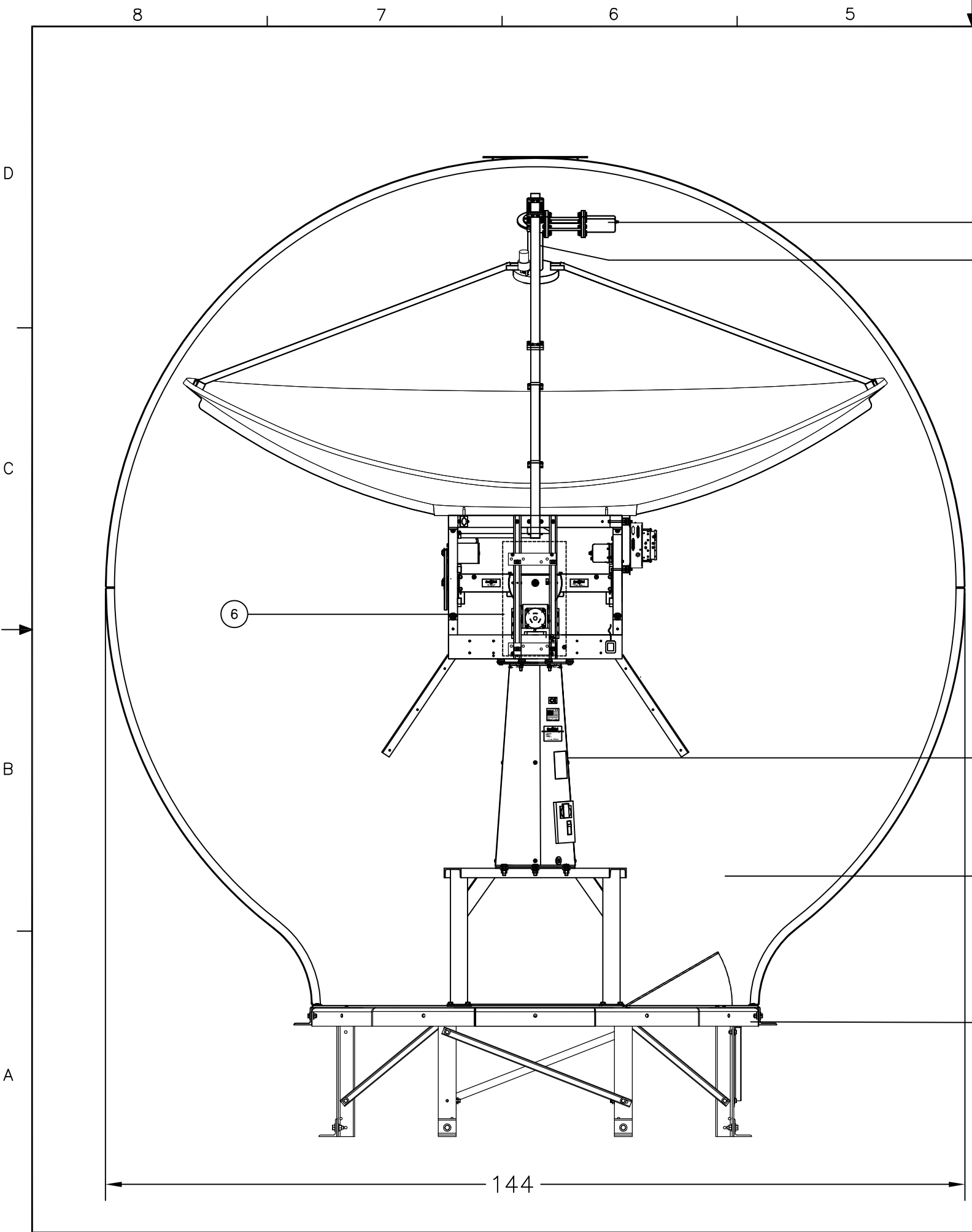

REVISION HISTORY				
REV	ECO#	DATE	DESCRIPTION	BY
B	6287	6-26-08	REMOVED ITEM 31 ON -5 & -6 ONLY.	SL
B1	N/A	8-26-08	ADDED -7.	KRB
B2	N/A	2-19-09	ADDED -8.	MSF
B3	N/A	9-15-09	ADDED DASHES -101, -102, -106	MSF
B4	N/A	9-29-09	ADDED DASH -103	MSF

DASH #	BAND	POL	WATT	RF MFR:	LNB #	OTHER (AC-DOME)	
-1	C	CIR	25W	CODAN MBUC	3130F		
-2	C	CIR	25W	CODAN MBUC	3130F	MARLINK	
-3	C	CIR	40W	CODAN MBUC	3130F		
-4	C	CIR	40W	CODAN MBUC	3130F	NO BDE	
-5	C	CIR	40W	CODAN MBUC	3130F	NO BDE, NO BUC	
-6	C	CIR	N/A	N/A	N/A	NO BUC, NO LNB	
-7	C	CIR	25W	CODAN MBUC	3130F	NO DAC	
-8	C	CIR	40W	CODAN MBUC	3120F	NO BDE	
-101	C	CIR	25-40W	CODAN MBUC	N/A		
-102	C	CIR	25-40W	CODAN MBUC	N/A	NO BDE	
-103	C	CIR	25-40W	CODAN MBUC	N/A	NO DOME	ZERO QTY RF BOM
-106	C	CIR	25-40W	CODAN MBUC	N/A	MARLINK	

- REFERENCE DRAWINGS:**
- 125075 SYSTEM BLOCK DIAGRAM
 - 125497 PEDESTAL UNLIMITED AZ SCHEMATIC
 - 125076 ANTENNA SYSTEM SCHEMATIC
 - 125077 PEDESTAL ASSEMBLY
 - 121910 SHIPYARD SPEC.
 - 124877 DECAL KIT, XX97

NOTES: UNLESS OTHERWISE SPECIFIED
 1. APPLY ADHESIVE PER SEATEL SPEC. 121730.

TOLERANCES UNLESS OTHERWISE SPECIFIED X.X = ±.050 X.XX = ±.020 X.XXX = ±.005 ANGLES: ±.5° INTERPRET TOLERANCING PER ASME Y14.5M - 1994		DRAWN BY: SMS	 4030 NELSON AVENUE CONCORD, CA 94520 Tel. 925-798-7979 Fax. 925-798-7986
MATERIAL: N/A		DRAWN DATE: 5-27-08	
FINISH: N/A		APPROVED BY:	TITLE: SYSTEM, 9707D-70 W/ SPIDER
3rd ANGLE PROJECTION		APPROVED DATE:	DRAWING NUMBER: 128390
		SIZE: B SCALE: NONE	REV: B4
		FIRST USED: XX07	SHEET NUMBER: 1 OF 1

SINGLE LEVEL MFG BILL OF MATERIAL

FIND	QTY	PART NO	REV	DESCRIPTION	REFERENCE DESIGNATOR
1	1 EA	128389-1	A	GENERAL ASS'Y, 9707D-70	
2	1 EA	111365-X		(REF ONLY) RADOME ASS'Y, 144 INCH	
4	1 EA	125498-1	C	FEED ASS'Y, C-BAND, CIRCULAR, DISHSCA	
5	1 EA	124571-X		(REF ONLY) SSPB, C-BAND, MBUC, CODAN	
6	1 EA	124556-X		(REF ONLY) LNB, C-BAND PLL, NORSAT 30	
17	1 EA	117168-6	P1	MODEM ASS'Y, PEDESTAL, 3 CH, 75 OHM,	
18	1 EA	117168-2	P1	MODEM ASS'Y, BASE, 3 CH, 75 OHM	
19	1 EA	117611-3	H	MODEM ASS'Y, PEDESTAL, 3 CH, 50 OHM	
20	1 EA	117611-4	H	MODEM ASS'Y, BASE, 3 CH, 50 OHM	
21	1 EA	115708-X		(REF ONLY) CIRCUIT BREAKER BOX ASS'Y	
22	1 EA	125570-4	G1	POWER SUPPLY ASS'Y, COSEL 150W, RH EN	
23	1 EA	123845-3	E	PCU ENCLOSURE ASS'Y, 07	
24	1 EA	116034	F	HOME SWITCH ASS'Y, SHIELDED	
25	1 EA	122452-1	E	LEVEL CAGE/SPINDLE ASS'Y, 90 DEGREE	
31	1 EA	125411-3	J	DAC-2202, SCPC RCVR, 9 WIRE IF	
32	1 EA	116881-18	D	MUX RACK PANEL ASS'Y, RX SS, SF, SPLI	
33	1 EA	116676	B2	TERMINAL MOUNTING STRIP ASS'Y, ACU	
40	1 EA	125726-3	B	HARNESS ASS'Y, BRAKE, 56 IN, XX07	
41	1 EA	121425-1	D4	HARNESS ASS'Y, INTERFACE, 4003	
42	1 EA	125496-1	A1	HARNESS ASS'Y, PEDESTAL, REFERENCE, X	
43	1 EA	123305-3	B	HARNESS ASS'Y, 3BLDC, 97B	
44	1 EA	125476-1	A4	HARNESS ASS'Y, M & C, ADD-ON, CODAN B	
45	1 EA	116298-6	G	INTERFACE HARNESS ASS'Y, ACU TO MODEM	
46	1 EA	120643-25	B	CABLE ASS'Y, RS232, 9-WIRE, STRAIGHT,	
56	1 EA	116700-6	F	CABLE ASS'Y, RG223, N(M)-F(M), 6 FT.	
57	2 EA	111115-6	B	CABLE ASS'Y, F(M)-F(M), 6 FT.	
58	1 EA	111115-1	B	CABLE ASS'Y, F(M)-F(M), 1 FT.	
59	2 EA	114972-9	M	CABLE ASS'Y, SMA(M) - SMA(M), 6 IN	

Sea Tel
COBHAM

SYSTEM BLOCK DIAGRAM, 9707D-70

PROD FAMILY LIT	EFF. DATE 12/15/2009	SHT 1 OF 3	DRAWING NUMBER 125075-3	REV G
--------------------	-------------------------	------------	-------------------------------	-----------------

SINGLE LEVEL MFG BILL OF MATERIAL

FIND	QTY	PART NO	REV	DESCRIPTION	REFERENCE DESIGNATOR
60	1 EA	113303-10	T1	CABLE ASS'Y, SMA 90 - SMA (M), 8 IN	
61	2 EA	114972-2	M	CABLE ASS'Y, SMA(M) - SMA(M), 72 IN	
62	1 EA	121281	A	CABLE ASS'Y, SMA(F)-SMA(M), 3 IN.	
63	2 EA	113303-5	T1	CABLE ASS'Y, SMA 90 - SMA (M), 84 IN	
64	1 EA	122583-10	A	CABLE ASS'Y, RG-6, F(M) TO F(M), 10FT	
65	1 EA	110873-4	E	RF SPLITTER, 2-WAY, 1-CH DC PASS, F	
66	1 EA	115492-8	C1	ADAPTER, SMA(F)-N(M)	
67	3 EA	115492-1	C1	ADAPTER, N(F)-SMA(F), W/FLANGE	
68	1 EA	110567-19		ADAPTER, N(F)-N(F), STRAIGHT, FLANGE	
69	1 EA	121008-72	D2	CABLE ASS'Y, AC INPUT, 72 IN. (SPADE	
70	1 EA	124288-12	G	CABLE ASS'Y, AC POWER, 12 IN	
71	1 EA	124287-56	D	CABLE ASS'Y, PEDESTAL AC POWER	
72	1 EA	116466	D	ROTARY JOINT, 4.5 GHz, DUAL COAX.	
73	1 EA	121250-1	C3	POWER RING ASS'Y, 22 IN, 66 IN. CONTA	
91	1 EA	117696-2	B	WAVEGUIDE, WR-229, 90 DEG E-BEND	
92	1 EA	129948-1	A2	C BAND RADAR TRANSMIT REJECT FILTER	
101	2 EA	112991-3	E3	WAVEGUIDE, WR-137, FLEXGUIDE, 72 IN	
102	1 EA	112988-7	B2	WAVEGUIDE, WR-137, 90 DEG E-BEND, 2 X	

<h1 style="margin: 0;">Sea Tel</h1> <p style="margin: 0;"><i>COBHAM</i></p>				
<p>SYSTEM BLOCK DIAGRAM, 9707D-70</p>				
PROD FAMILY LIT	EFF. DATE 12/15/2009	SHT 2 OF 3	DRAWING NUMBER 125075-3	REV G

REVISION HISTORY

REV	ECO#	DATE	DESCRIPTION	BY
D	6226	5-28-08	ADD DASH -3.	SMS
E	6287	06-26-08	ITEM 31 WS 125411-2.	SL
F	6366	9-03-08	ON -3 VERSION: MODEM ASS'Y, ITEM 17 WAS 117168-1	RJW
G	6608	03-31-09	ON -3 VERSION: ITEM 91 WS 119686; ITEM 92 WS 117373-1; DELETED ITEM 100; UPDATED DRAWING FORMAT	HT

ABOVE DECKS EQUIPMENT
BELOW DECKS EQUIPMENT

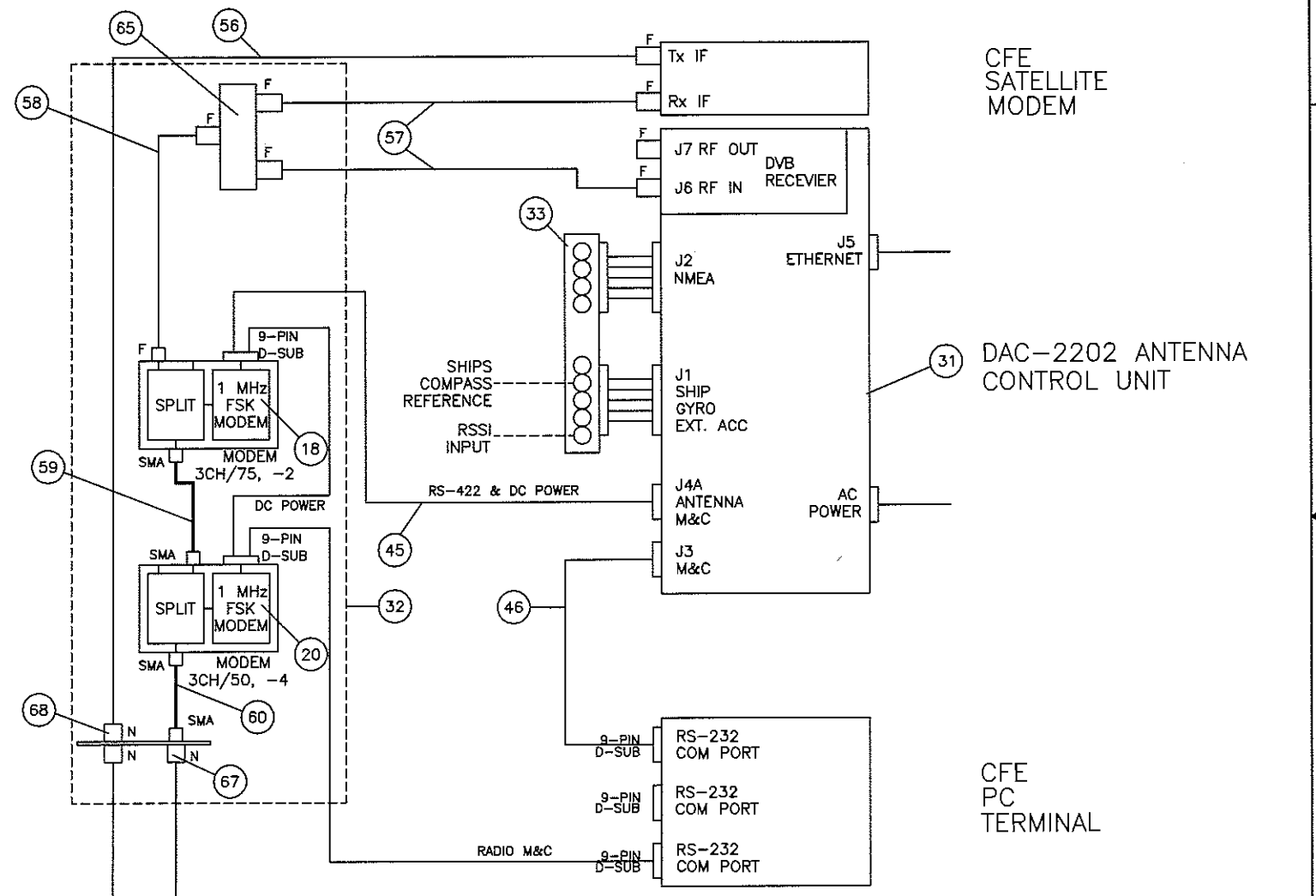
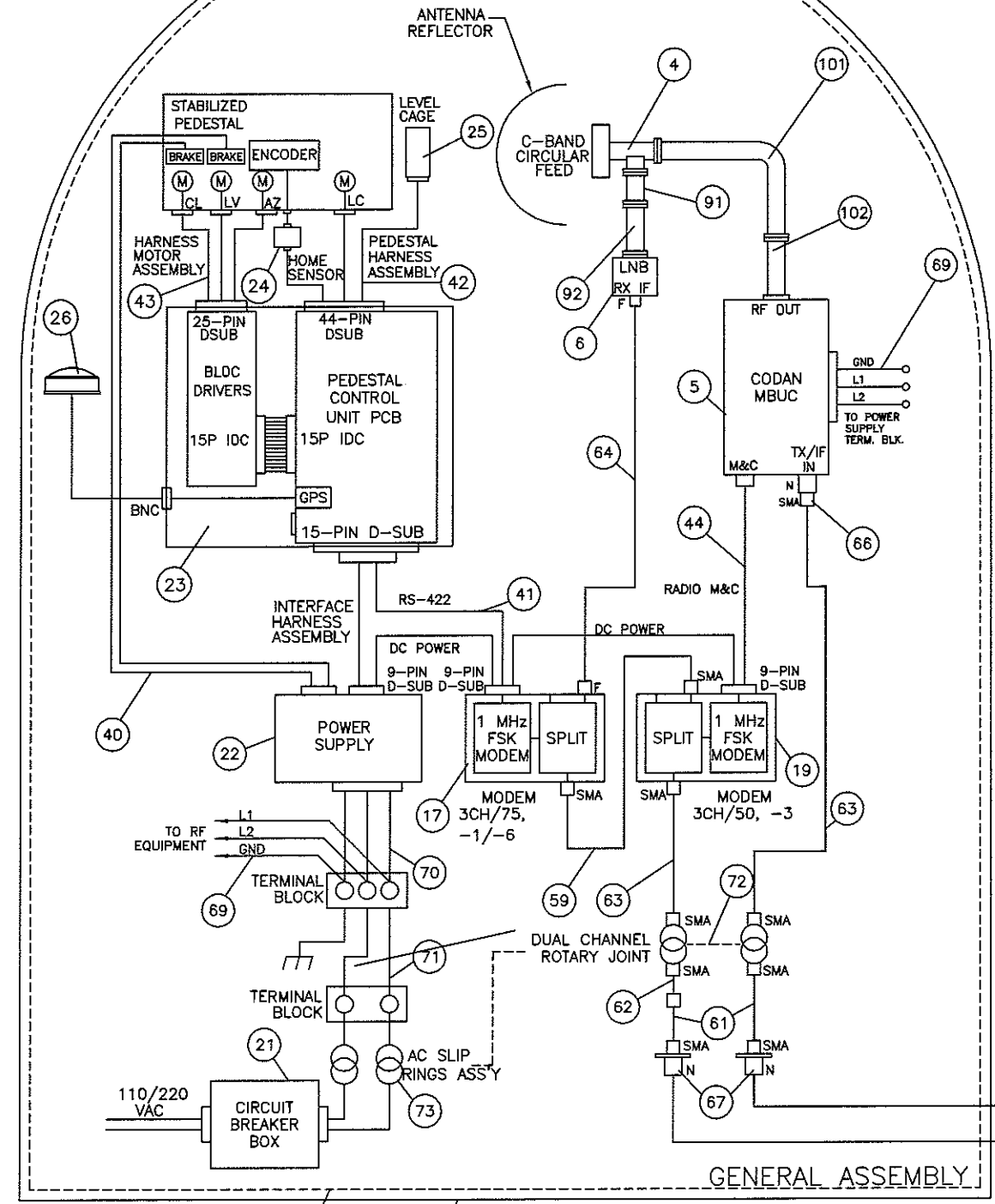

REFERENCE DRAWINGS:
125076 ANTENNA SYSTEM SCHEMATIC
125497 PEDESTAL HARNESS SCHEMATIC

DASH	DESCRIPTION	PART #
-1	SYSTEM, 9707	125072
-2	SYSTEM, 9707 W/SPIDER	125779
-3	SYSTEM, 9707D-70	128390

UNLESS OTHERWISE SPECIFIED DIMENSIONS ARE IN INCHES. X.X = ±.050 X.XX = ±.020 X.XXX = ±.005 ANGLES: ±.5°	DRAWN BY: T PATEL	Sea Tel COBHAM Tel. 925-798-7979 Fax. 925-798-7986
	DRAWN DATE: 05-10-06	
INTERPRET TOLERANCING PER ASME Y14.5M - 1994	APPROVED BY: <i>[Signature]</i>	TITLE: SYSTEM BLOCK DIAGRAM
MATERIAL: N/A	APPROVED DATE: 4-2-09	9707-70
FINISH: N/A	SIZE: B	SCALE: NOT TO SCALE
	FIRST USED:	DRAWING NUMBER: 125075
3rd ANGLE PROJECTION		REV: G
		SHEET NUMBER: 1 OF 1

SINGLE LEVEL MFG BILL OF MATERIAL

FIND	QTY	PART NO	REV	DESCRIPTION	REFERENCE DESIGNATOR
1	1 EA	128144-1	A2	PEDESTAL ASS'Y, XX07	
2	1 EA	121605-4	F1	POWER ASS'Y, 220V, 34 IN. SINGLE SHRO	
3	1 EA	125074-1	F	EQUIPMENT FRAME ASS'Y, XX07	
4	1 EA	116803	C	REFLECTOR, OFFSET, 2.4M	
5	1 EA	120292	D1	FEED STRUT, TOP	
6	1 EA	120293	A1	FEED STRUT, LEFT	
7	1 EA	120294	A1	FEED STRUT, RIGHT	
8	1 IN	108955-10		SPIRAL WRAP, BLACK, 3/8	(NOT SHOWN)
12	1 EA	121655-1	F	LABELS INSTALLATION	
26	1 EA	112991-3	E3	WAVEGUIDE, WR-137, FLEXGUIDE, 72 IN	
29	1 EA	112988-7	B2	WAVEGUIDE, WR-137, 90 DEG E-BEND, 2 X	NOT SHOWN
36	1 EA	122583-10	A	CABLE ASS'Y, RG-6, F(M) TO F(M), 10FT	NOT SHOWN
40	1 EA	124287-56	D	CABLE ASS'Y, PEDESTAL AC POWER	NOT SHOWN
41	1 EA	121008-72	D2	CABLE ASS'Y, AC INPUT, 72 IN. (SPADE	NOT SHOWN
44	2 EA	115492-1	C1	ADAPTER, N(F)-SMA(F), W/FLANGE	NOT SHOWN
46	3 EA	117218-2		GASKET, WR-137, (CPRG FULL)	NOT SHOWN
50	6 EA	114580-029		WASHER, FLAT, 1/4, S.S.	
51	6 EA	114581-029		WASHER, LOCK, 1/4, S.S.	
53	3 EA	114586-540		SCREW, HEX HD, 1/4-20 x 1-1/4, S.S.	
54	3 EA	114625-108		WASHER, FENDER, 1/4 IN, 18-8 S.S. (1-	
55	6 EA	114583-029		NUT, HEX, 1/4-20, S.S.	
60	3 EA	118294-3	B	HARDWARE KIT, WR-137, CPR FLANGE	
70	4 EA	114586-645		SCREW, HEX HD, 3/8-16 x 7/8, S.S.	
71	4 EA	114580-031	A	WASHER, FLAT, 3/8, S.S.	

Sea Tel				
COBHAM				
GENERAL ASS'Y, 9707D-70				
PROD FAMILY 97 TX/RX	EFF. DATE 12/15/2009	SHT 1 OF 2	DRAWING NUMBER 128389-1	REV A

8 7 6 5 4 3 2 1

REVISION HISTORY			
REV	ECO#	DATE	DESCRIPTION

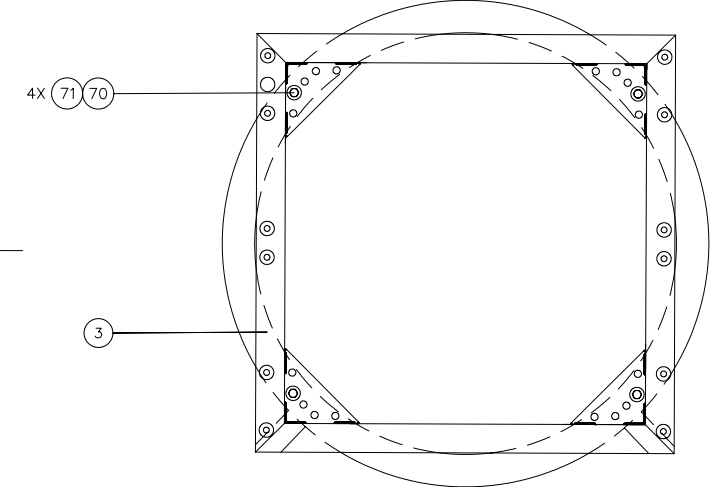
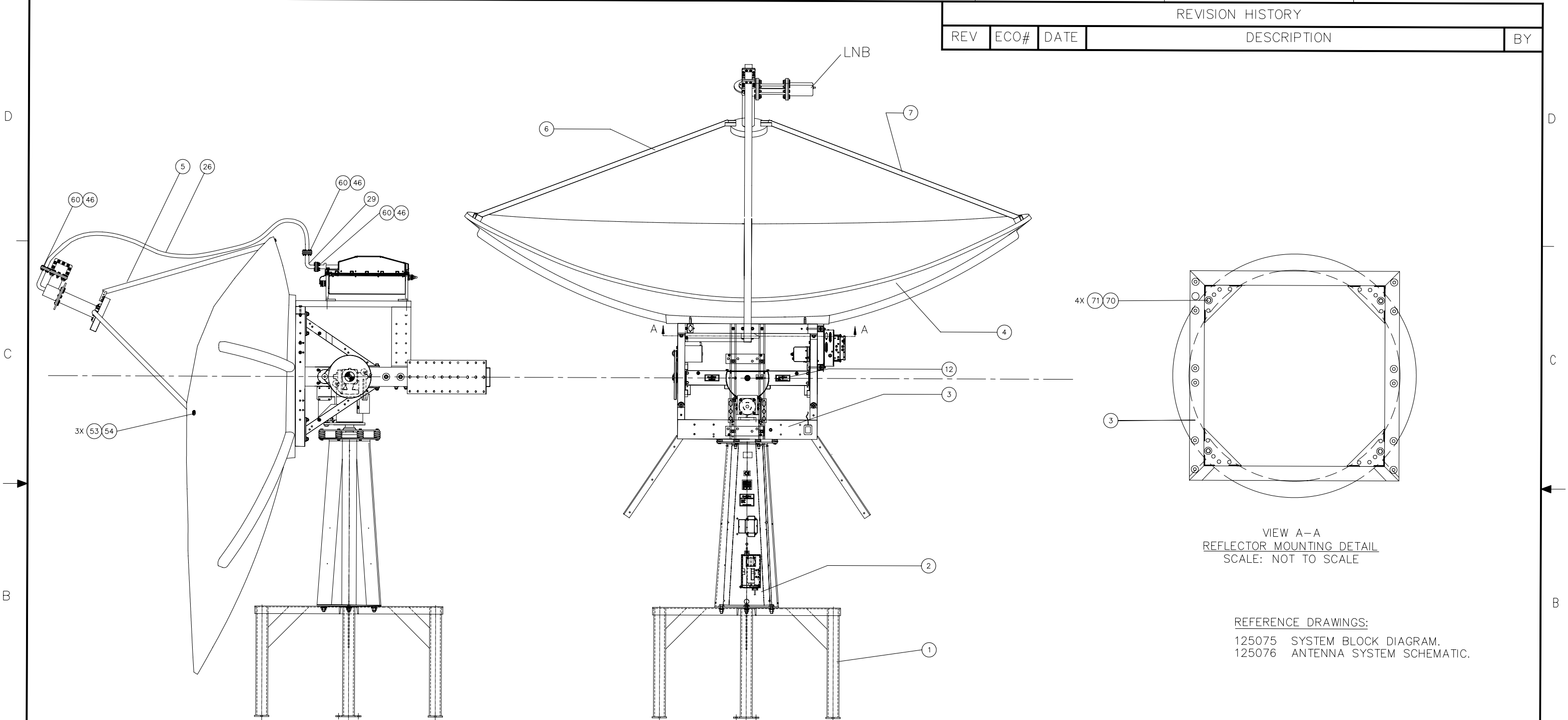

VIEW A-A
REFLECTOR MOUNTING DETAIL
SCALE: NOT TO SCALE

REFERENCE DRAWINGS:
125075 SYSTEM BLOCK DIAGRAM.
125076 ANTENNA SYSTEM SCHEMATIC.

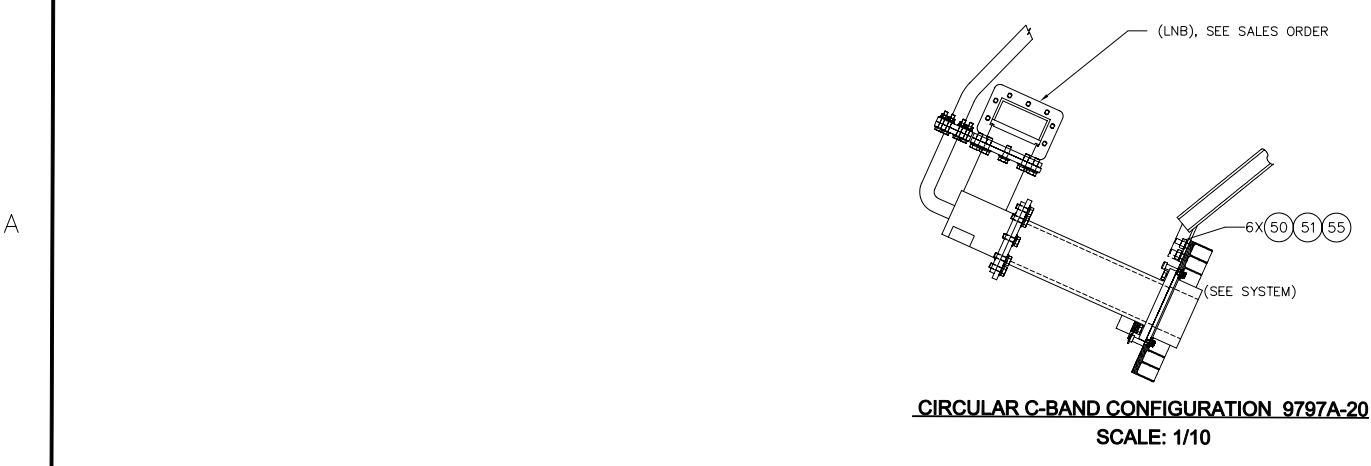

NOTES: UNLESS OTHERWISE SPECIFIED
1. APPLY ADHESIVE PER SEATEL SPEC. 121730.

TOLERANCES UNLESS OTHERWISE SPECIFIED		DRAWN BY: SMS		 4030 NELSON AVENUE CONCORD, CA 94520 Tel. 925-798-7979 Fax. 925-798-7986	
X.X = ±.050 X.XX = ±.020 X.XXX = ±.005 ANGLES: ±.5° INTERPRET TOLERANCING PER ASME Y14.5M - 1994		DRAWN DATE: 5-27-08			
MATERIAL: N/A		APPROVED BY:		TITLE: GENERAL ASSEMBLY	
FINISH: N/A		APPROVED DATE:		DRAWING NUMBER: 9707D-70	
SIZE: B		SCALE: NONE		REV: A	
3rd ANGLE PROJECTION				FIRST USED:	
SHEET NUMBER: 1 OF 1				DRAWING NUMBER: 128389	

REV	ECO#	DATE	DESCRIPTION	BY
B	5943	11-20-07	NOTE 1 ADDED	MSF
C	6226	5-27-08	AC TERMINAL BLOCK UPDATED; P/Ns 120851, 128390, 125779, 117149, & 121172 ADDED TO REF. DWGS.	MSF
C1	6622	4-30-09	MODEM P/N 117168-6 WAS 117168-1; P/Ns 125779, 125072 DLT'D FROM REF. DWGS	MSF

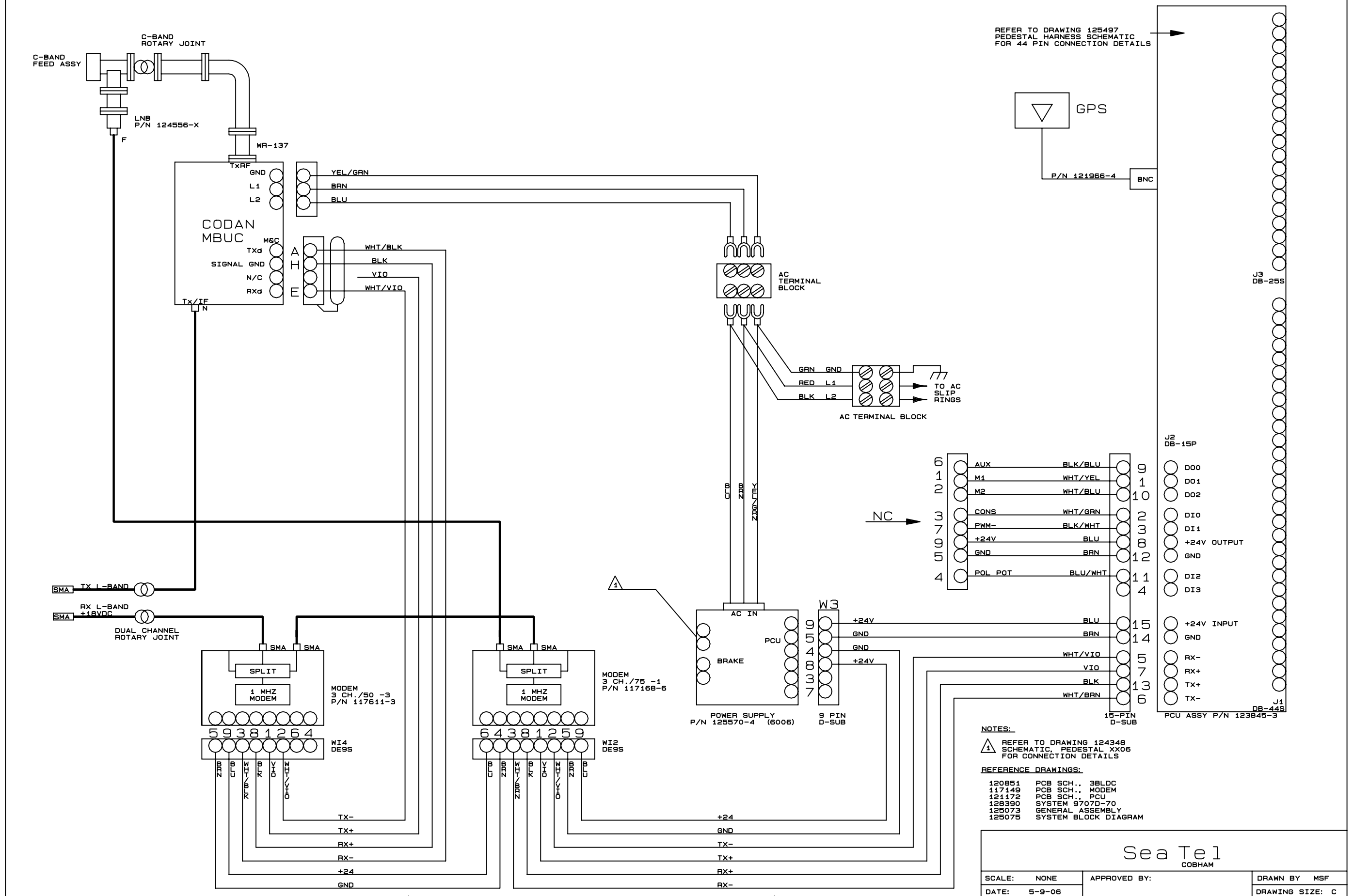

NOTES:
 ⚠ REFER TO DRAWING 124348 SCHEMATIC, PEDESTAL XX06 FOR CONNECTION DETAILS

REFERENCE DRAWINGS:
 120851 PCB SCH.. 3BLDC
 117149 PCB SCH.. MODEM
 121172 PCB SCH.. PCU
 128390 SYSTEM 9707D-70
 125073 GENERAL ASSEMBLY
 125075 SYSTEM BLOCK DIAGRAM

Sea Te1
COBHAM

SCALE: NONE	APPROVED BY:	DRAWN BY MSF
DATE: 5-9-06		DRAWING SIZE: C
ANTENNA SYSTEM SCHEMATIC		
MODEL: 9707	SHT. 1 OF 1	DRAWING NUMBER REV 125076 C1

SINGLE LEVEL MFG BILL OF MATERIAL

FIND	QTY	PART NO	REV	DESCRIPTION	REFERENCE DESIGNATOR
1	1 EA	117696-2	B	WAVEGUIDE, WR-229, 90 DEG E-BEND	
2	1 EA	129948-1	A2	C BAND RADAR TRANSMIT REJECT FILTER	
3	1 EA	117507	B	WAVEGUIDE, WR-137, 20 DEG E-BEND	
4	1 EA	123283	A2	FEED, C-BAND, CIRCULAR, DISHSCAN, TUN	
5	2 EA	123618-37		GASKET, WR-229, CPR-229G, CHOKE	
6	2 EA	117218-2		GASKET, WR-137, (CPRG FULL)	
7	1 EA	112991-2	E3	WAVEGUIDE, WR-137, FLEXGUIDE, 24 IN	
10	12 EA	108519-4	E	WEIGHT, TRIM 7.0 OZ, BLUE	
50	24 EA	114593-169		SCREW, SOCKET HD, 10-32 x 1, S.S.	
57	48 EA	114580-011		WASHER, FLAT, #10, S.S.	
58	24 EA	114581-011		WASHER, LOCK, #10, S.S.	
59	24 EA	114583-011	A	NUT, HEX, 10-32, S.S.	
60	19 EA	114586-537		SCREW, HEX HD, 1/4-20 x 3/4, S.S.	
61	20 EA	114586-540		SCREW, HEX HD, 1/4-20 x 1-1/4, S.S.	
62	4 EA	114586-545		SCREW, HEX HD, 1/4-20 x 2-1/2, S.S.	
67	57 EA	114580-029		WASHER, FLAT, 1/4, S.S.	
68	29 EA	114581-029		WASHER, LOCK, 1/4, S.S.	
69	24 EA	114583-029		NUT, HEX, 1/4-20, S.S.	

<h1 style="margin: 0;">Sea Tel</h1> <p style="margin: 0;"><i>COBHAM</i></p>				
XX97A FEED SUB-ASS'Y, C-BAND, CIRC., DSHSCN / FIELD INSTAL				
PROD FAMILY COMMON	EFF. DATE 12/15/2009	SHT 1 OF 2	DRAWING NUMBER 123351	REV C

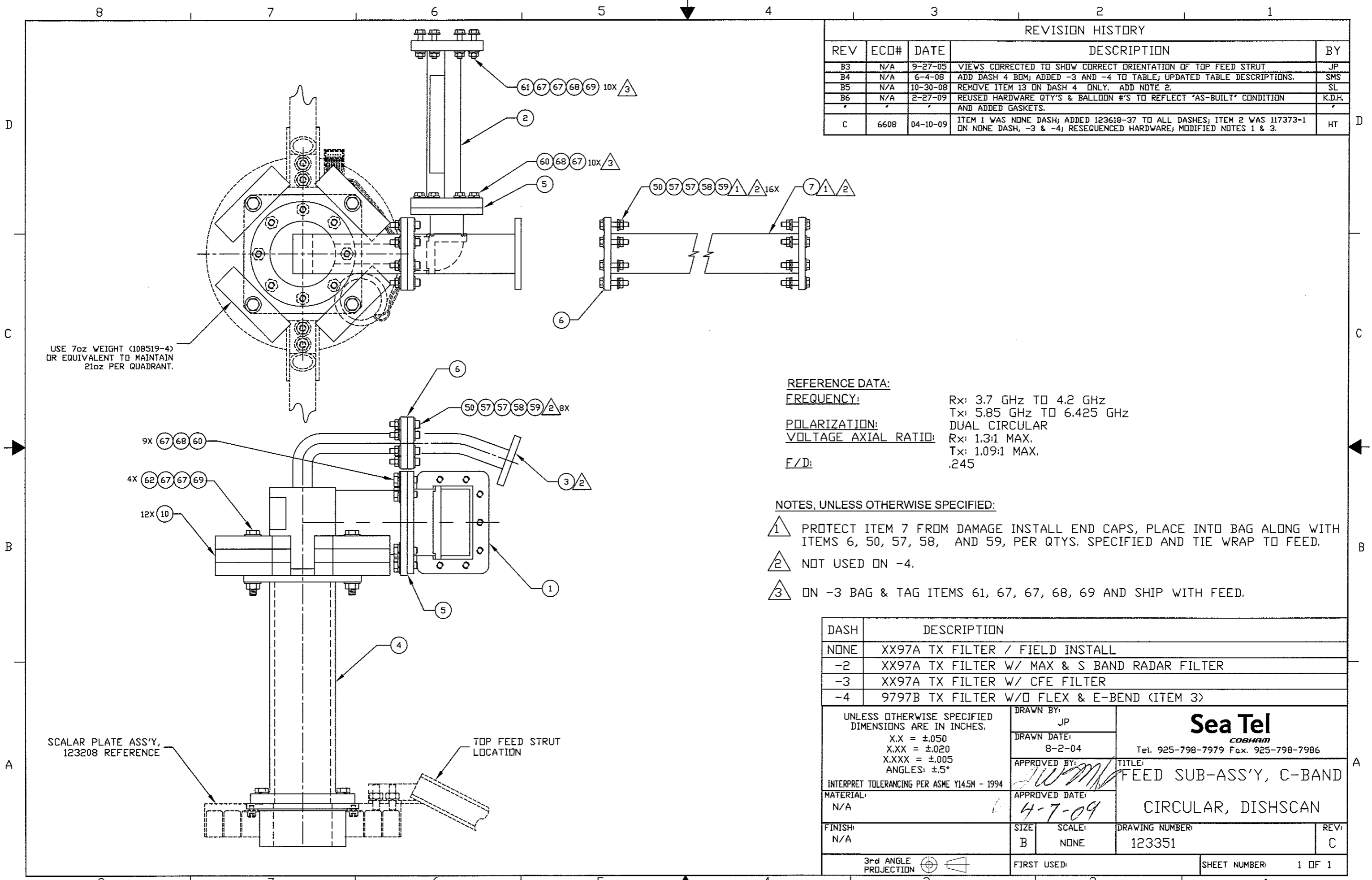

REVISION HISTORY				
REV	ECD#	DATE	DESCRIPTION	BY
B3	N/A	9-27-05	VIEWS CORRECTED TO SHOW CORRECT ORIENTATION OF TOP FEED STRUT	JP
B4	N/A	6-4-08	ADD DASH 4 BOM; ADDED -3 AND -4 TO TABLE; UPDATED TABLE DESCRIPTIONS.	SMS
B5	N/A	10-30-08	REMOVE ITEM 13 ON DASH 4 ONLY. ADD NOTE 2.	SL
B6	N/A	2-27-09	REUSED HARDWARE QTY'S & BALLOON #'S TO REFLECT 'AS-BUILT' CONDITION AND ADDED GASKETS.	K.D.H.
C	6608	04-10-09	ITEM 1 WAS NONE DASH; ADDED 123618-37 TO ALL DASHES; ITEM 2 WAS 117373-1 ON NONE DASH, -3 & -4; RESEQUENCED HARDWARE; MODIFIED NOTES 1 & 3.	HT

REFERENCE DATA:

FREQUENCY: Rx: 3.7 GHz TO 4.2 GHz
Tx: 5.85 GHz TO 6.425 GHz

POLARIZATION: DUAL CIRCULAR

VOLTAGE AXIAL RATIO: Rx: 1.3:1 MAX.
Tx: 1.09:1 MAX.

F/D: .245

NOTES, UNLESS OTHERWISE SPECIFIED:

- ① PROTECT ITEM 7 FROM DAMAGE INSTALL END CAPS, PLACE INTO BAG ALONG WITH ITEMS 6, 50, 57, 58, AND 59, PER QTY'S. SPECIFIED AND TIE WRAP TO FEED.
- ② NOT USED ON -4.
- ③ ON -3 BAG & TAG ITEMS 61, 67, 67, 68, 69 AND SHIP WITH FEED.

DASH	DESCRIPTION
NONE	XX97A TX FILTER / FIELD INSTALL
-2	XX97A TX FILTER W/ MAX & S BAND RADAR FILTER
-3	XX97A TX FILTER W/ CFE FILTER
-4	9797B TX FILTER W/O FLEX & E-BEND (ITEM 3)

UNLESS OTHERWISE SPECIFIED DIMENSIONS ARE IN INCHES. X.X = ±.050 X.XX = ±.020 X.XXX = ±.005 ANGLES: ±.5° INTERPRET TOLERANCING PER ASME Y14.5M - 1994	DRAWN BY: JP	Sea Tel <small>COBHAM</small> Tel. 925-798-7979 Fax. 925-798-7986		
	DRAWN DATE: 8-2-04			
APPROVED BY: <i>[Signature]</i>	TITLE: FEED SUB-ASS'Y, C-BAND			
APPROVED DATE: 4-7-09	CIRCULAR, DISHSCAN			
MATERIAL: N/A	SIZE: B	SCALE: NONE	DRAWING NUMBER: 123351	REV: C
FINISH: N/A	FIRST USED:	DRAWING NUMBER: 123351		SHEET NUMBER: 1 OF 1

NOTES: (UNLESS OTHERWISE SPECIFIED)

1. ALL WEIGHTS GIVEN ARE FOR INFORMATION ONLY. DO NOT USE FOR DESIGN. REFER TO 121910.
2. SEATEL DOES NOT PROVIDE LIFTING HARDWARE OR STRAPS.

REVISION HISTORY				
REV	ECO#	DATE	DESCRIPTION	BY
B1	N/A	11-1-05	SMT. 2: TABLE 1 MODEL 9797A-50 WEIGHT WS 720; MODEL 9797A-59, 56, 66, 62 & 8797A-29 WEIGHT ADDED	MSF
B2	N/A	7-14-09	DIM BX (#.69) EQ. SP. WAS BX (#.56) EQ. SP.	MSF

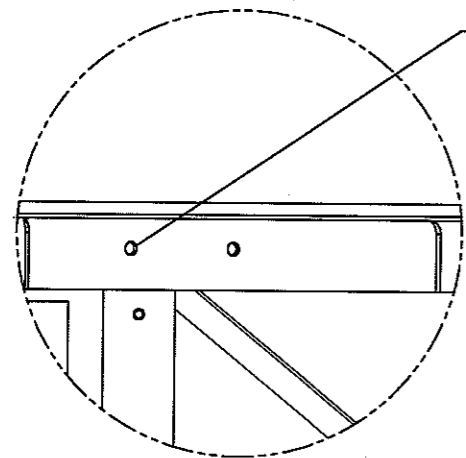

DETAIL A

SCALE: NONE

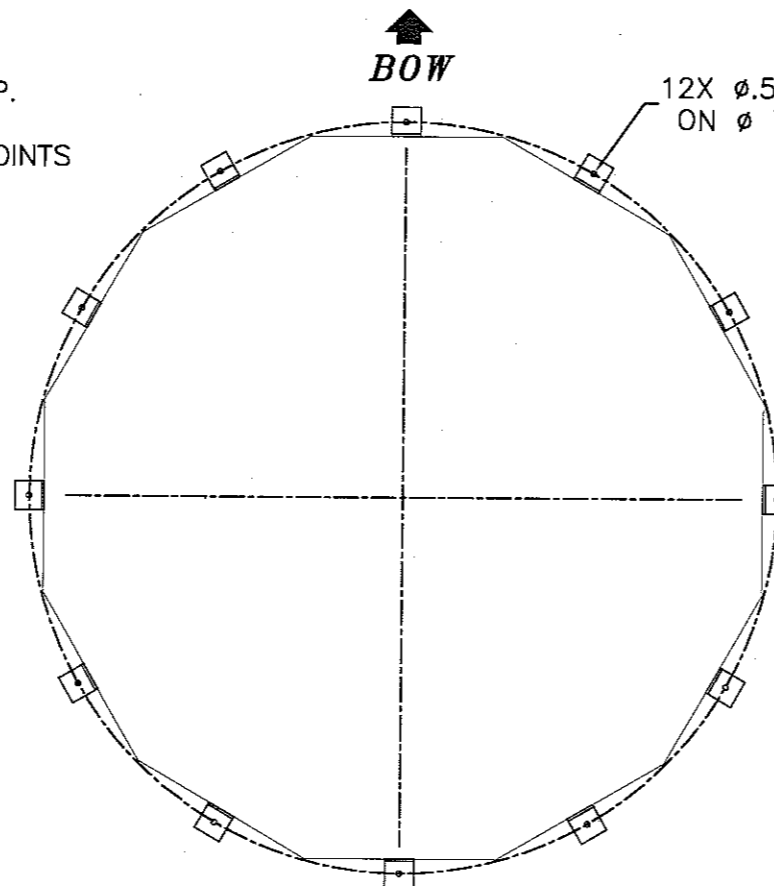

FLUSH MOUNT RADOME MOUNTING HOLE PATTERN

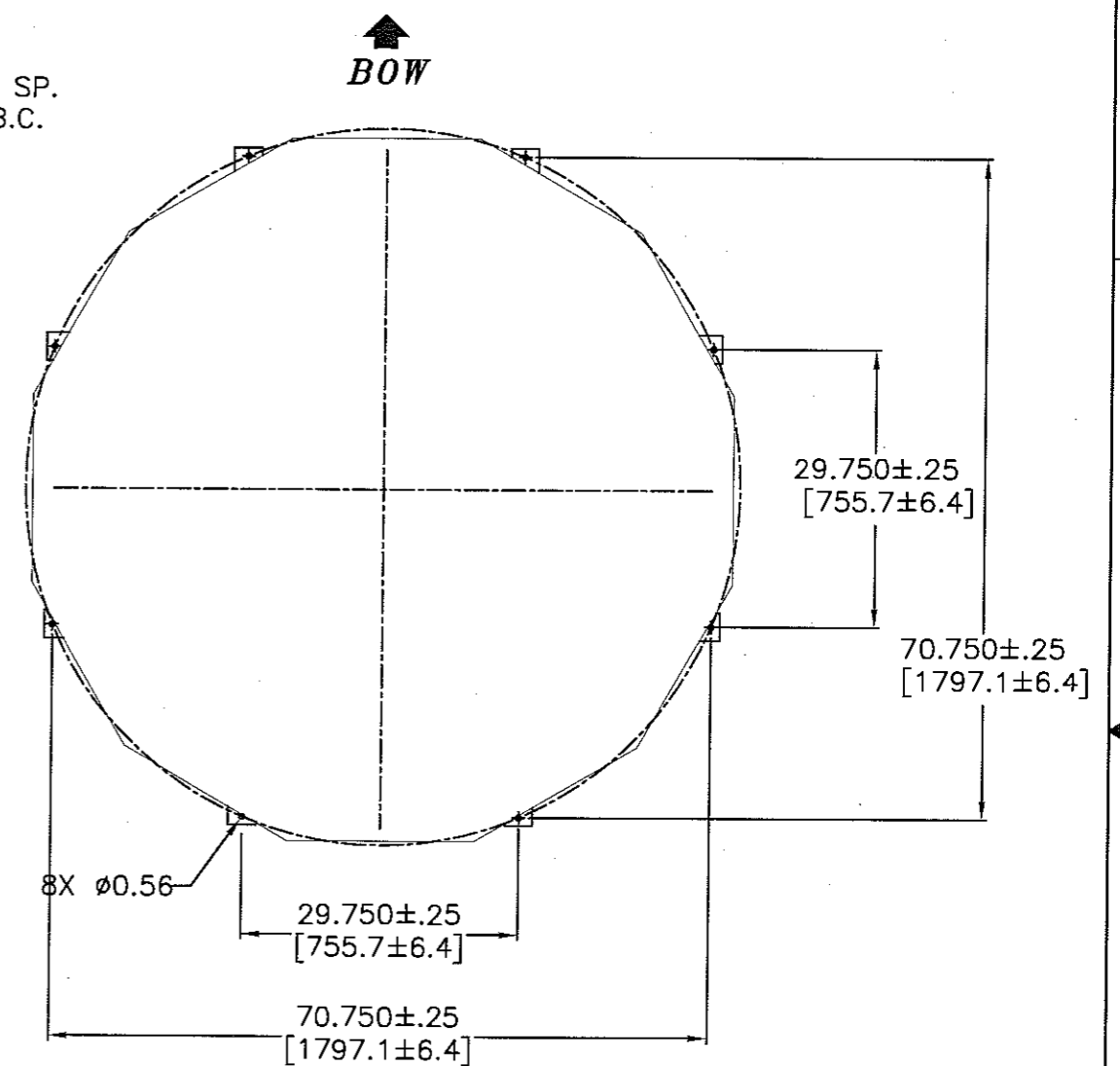

MOUNTING HOLE PATTERN W/LEGS

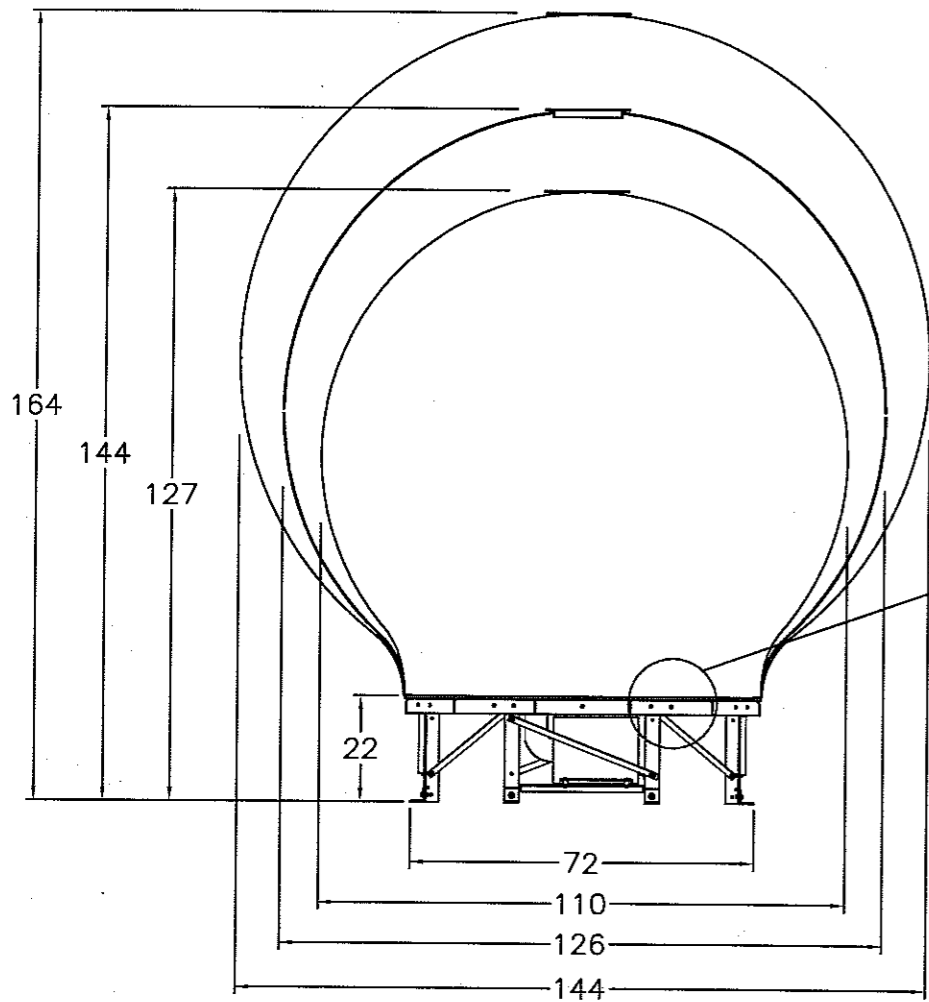

SCALE: NONE

UNLESS OTHERWISE SPECIFIED DIMENSIONS ARE IN INCHES. X.X = ±.050 X.XX = ±.020 X.XXX = ±.005 ANGLES: ±.5°	DRAWN BY: SCC		 Tel. 925-798-7979 Fax. 925-798-7986	
	DRAWN DATE: 01-03-05			
INTERPRET TOLERANCING PER ASME Y14.5M - 1994	APPROVED BY: 		TITLE: INSTALLATION ARRANGEMENT	
	APPROVED DATE: 07/14/09		DRAWING NUMBER: 123908	
FINISH:	SIZE: B	SCALE: 1:20	DRAWING NUMBER: 123908	REV: B2
3rd ANGLE PROJECTION			FIRST USED: XX97A	SHEET NUMBER: 1 OF 2

TABLE 1: GENERAL ASSEMBLY WEIGHT

ITEM DESCRIPTION	NET* WEIGHT (LB.)
9797A-09	455
9797A-11	565
9797A-21	555
9797A-27	575
9797A-32	625
9797A-38	615
9797A-40	545
9797A-43 (Dual C-Band)	720
9797A-45	545
9797A-46	625
9797A-49	485
9797A-50	565
9797A-51	685
9797A-53	695
9797A-59	545
12097A-2	585
9797A-56	565
8797A-29	645
9797A-66	555
9797A-62	685

*NET WEIGHT EXCLUDES SHIPPING PALLET
WEIGHT OF APPROX. 25 LB.

TABLE 2: BASE ASSEMBLY WEIGHT

ITEM DESCRIPTION	WEIGHT (Lb.) **
BASE ASSEMBLY: STEEL BASE, 21" LEGS	309
BASE ASSEMBLY: AL BASE, 21" LEGS	-
BASE ASSEMBLY: STEEL BASE, FLUSH MOUNT	-
BASE ASSEMBLY: AL BASE, FLUSH MOUNT	-

**ADD 100lbs FOR AIR CONDITIONER ASSEMBLY.

TABLE 3: RADOME ASSEMBLY WEIGHT

ITEM DESCRIPTION	WEIGHT (Lb.) ***
RADOME ASSEMBLY: 110" (DRY WEIGHT)	TBD
RADOME ASSEMBLY: 126" (DRY WEIGHT)	TBD
RADOME ASSEMBLY: 144" (DRY WEIGHT)	TBD

***WEIGHT GIVEN IS APPROXIMATE DRY WEIGHT. RADOME PANELS
CAN ABSORB UP TO 50% MOISTURE BY WEIGHT.

SIZE B	SCALE:	DRAWING NUMBER: 123908	REV: B2
SHEET NUMBER:			2 OF 2

SINGLE LEVEL MFG BILL OF MATERIAL

FIND	QTY	PART NO	REV	DESCRIPTION	REFERENCE DESIGNATOR
1	1 EA	109119-17	F2	RADOME FAB ASS'Y, 144 INCH, WHITE/SID	
9	3 EA	124903-1	B1	STRAIN RELIEF ASS'Y	
11	0 EA	114586-538		SCREW, HEX HD, 1/4-20 x 1, S.S.	INCLUDED IN HARDWARE KIT
12	0 EA	114586-541		SCREW, HEX HD, 1/4-20 x 1-1/2, S.S.	INCLUDED IN HARDWARE KIT
14	0 EA	114625-107		WASHER, FENDER, 1/4, (1 IN OD), S.S.	INCLUDED IN HARDWARE KIT
17	0 EA	114583-029		NUT, HEX, 1/4-20, S.S.	INCLUDED IN HARDWARE KIT
28	1 EA	109783-2		WRENCH, L	
0	12 EA	117762-1	B	SILICONE ADHESIVE, WHT RTV 122, 10.1	NOT SHOWN
0	1 EA	110327	M	HARDWARE KIT, 144 INCH RADOME	NOT SHOWN

<h1 style="margin: 0;">Sea Tel</h1> <p style="margin: 0;"><i>COBHAM</i></p>				
<p>RADOME ASS'Y, 144 INCH, WHITE/SIDE ACCESS</p>				
PROD FAMILY COMMON	EFF. DATE 12/15/2009	SHT 1 OF 1	DRAWING NUMBER 111365-17	REV N1

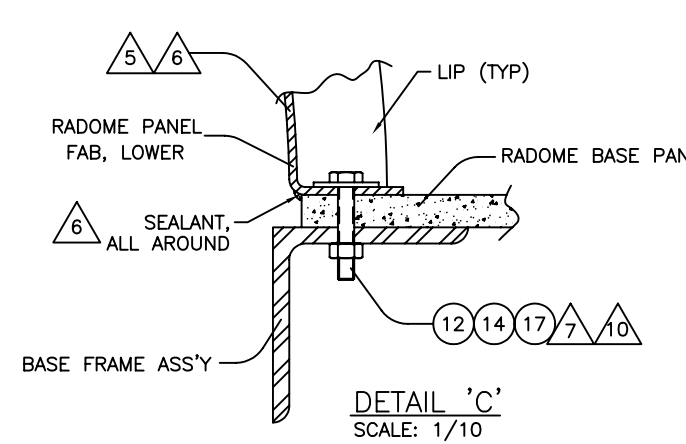
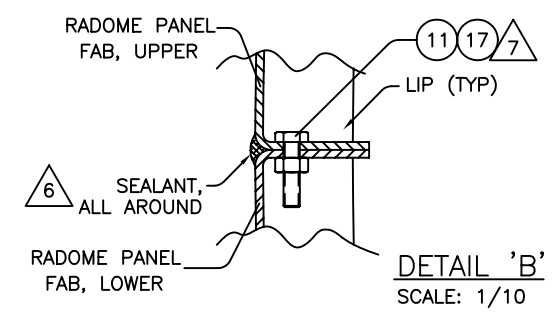
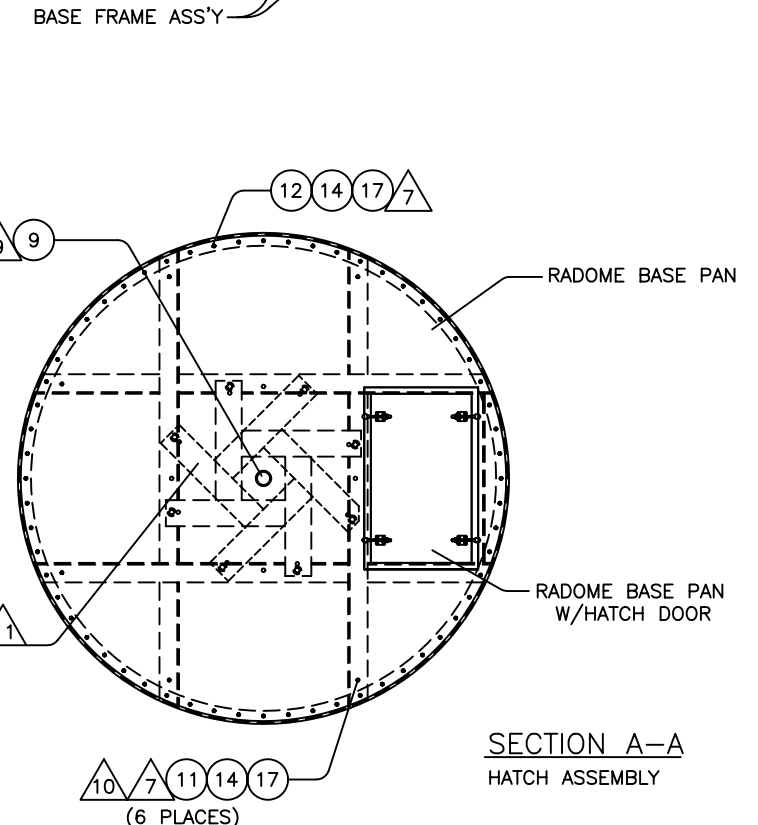
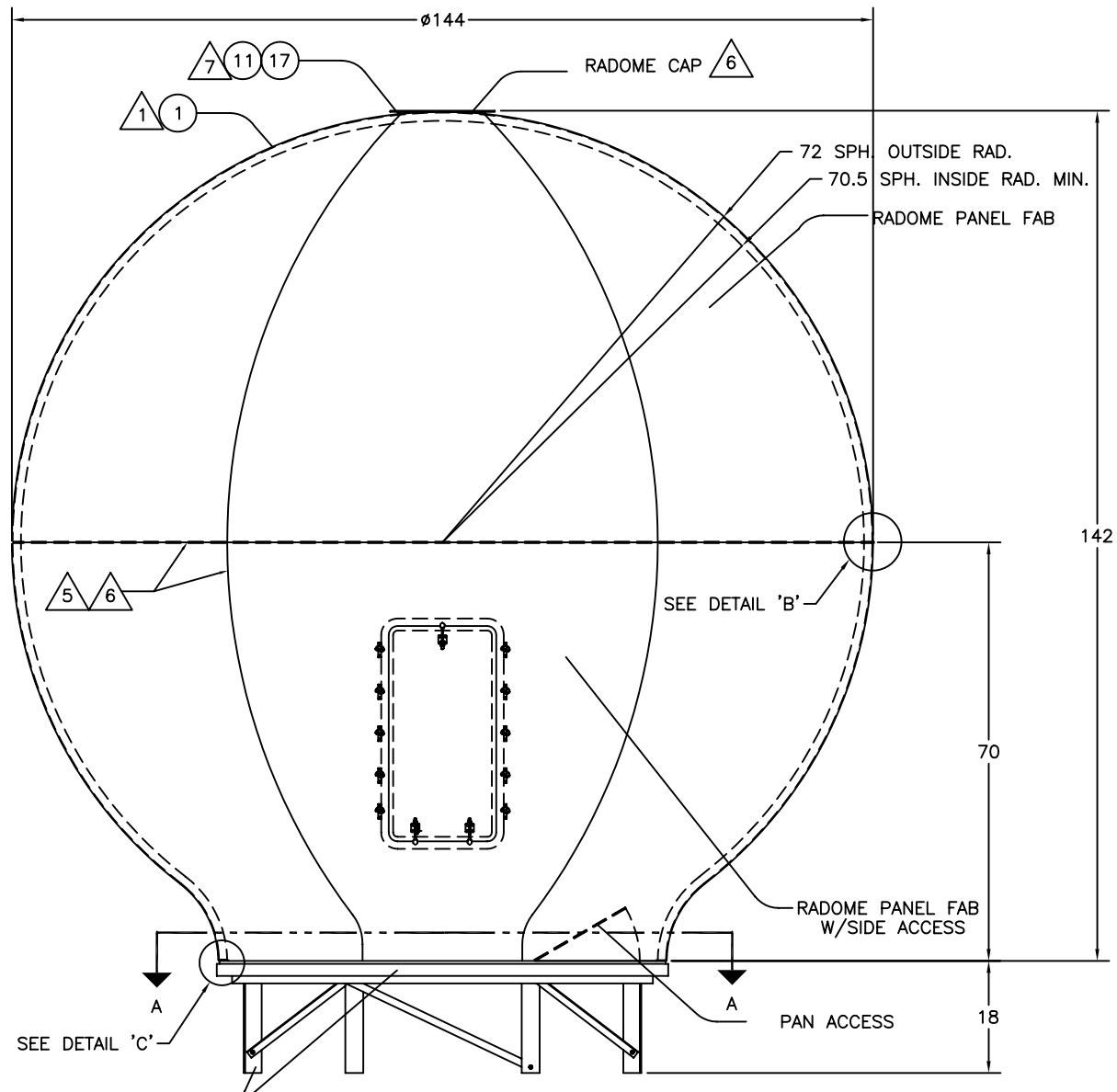

REV.	ECO#	DATE	DESCRIPTION	BY
D		6-13-97	REDRAWN; REV. C FILED OBSOLETE.	MAB
E		5-13-98	ITEM 5 P/N 110965-6 ADD'D.	MAB
F		6-23-98	BASE STAND MOUNTING LOCATION ADD'D TO SECTION A-A; NOTE 12 ADD'D.	MAB
G		7-8-98	DASH No's 9-16 ADD'D; NOTES 2 & 3 CHG'D FOR CORRECT BASE PAN & DASH No's.	MAB
H		5-24-99	ITEM 21 ADD'D.	CF
I		1-5-00	DASH No's 17-24 & PAN ACCESS CLMN ADD'D TO DASH TABLE; NOTES 2C & 2D ADD'D; ITEM 1 P/N's 109119-17 THRU -24 ADD'D.	MAB
J	3900	4-7-03	ADD'D ADDITIONAL LATCH TO SIDE DOOR; NOTE 5 " APPLYING GASKET"; ITEMS 19, 20 & 22 ; AND DASH 25. RENUMBERED NOTE ITEMS & CORRECTED BALLOONS. FOR ASSY W/SIDE ACCESS: CHG LATCH 108959 ITEM 31 TO QTY 3; SCREW 114587-829 ITEM 19 TO QTY 12; WASHER 114580-011 ITEM 20 TO QTY 12; NUT 114583-011 ITEM 22 TO QTY 12. FOR ASSY W/SIDE & PAN ACCESS: CHG ITEM 31 TO QTY 7; ITEM 19 TO QTY 28; ITEM 20 TO QTY 28 & ITEM 22 TO QTY 28.	LK
K	4083	10-08-03	CHANGED STRAIN RELIEFS FROM 109258-1 TO 109258-8. UPDATED BOM & DWG NOTES, BALLOON #'S & QTY TO MATCH CURRENT BUILD. REARRANGED DASH TABLE.	LK
L	4490	07-26-04	MOVE HW FOR SIDE ACCESS TO RADOME FAB ASSY. DEL ITEMS 19-20,22,29-33,35,SHEET 2.	AMN
M	4941	07-14-05	SILICON ADHESIVE CHANGED TO CLEAR FOR DASH 21.	V.S.
M1	N/A	9-6-05	ADDED DASH 28	LK
N	5050	11-7-05	STRAIN RELIEF WAS 109258-8	LK
N1	N/A	10-17-07	ADDED DASH 27	CK

DASH NO'S	CONFIGURATION		
	COLOR	FOAM	SIDE ACCESS
-1	WHITE	YES	YES
-17	WHITE	YES	YES
-18	WHITE	YES	YES
-21	US NAVY GREY	YES	YES
-25	BRIT GREY	YES	YES
-26	DANISH NAVY GREY	YES	YES
-27	SNOW WHITE	YES	YES

- NOTES:
- SELECT RADOME FAB ASS'Y 109119 AS PER SPECIFICATIONS IN CUSTOMERS SALES ORDERS.
 - N/A.
 - N/A.
 - APPLY ADHESIVE PER SEATEL SPEC. 121730.
 - APPLY MASKING TAPE ALONG VERTICAL AND HORIZONTAL EDGES OF ALL PANELS PRIOR TO CAULKING.
 - USE SILICON ADHESIVE TO SEAL VERTICAL AND HORIZONTAL EDGES OF ALL PANELS, RADOME CAP, AND ON BASE PAN UNDER PANELS.
 - APPLY ADHESIVE AS PER SEATEL SPEC 121730 TO ALL THREADED FASTENERS AT TIME OF FINAL ASSEMBLY AND TIGHTEN WITH TORQUE WRENCH PER FOLLOWING TABLE:

BOLT DIA.	THREAD PITCH	FT. LBS.	THREAD PITCH	FT. LBS.
1/4"	20	5.5	28	6.0
5/16"	18	10.0	24	11.4
3/8"	16	21.7	24	24.5
7/16"	14	32.4	20	38.4
1/2"	13	43.5	20	54.6
9/16"	12	57.5	18	68.0
5/8"	11	86.0	18	102.0
3/4"	10	152.0	16	182.0

- BASED ON WIND VELOCITY OF 100 MPH:
HORIZONTAL WIND SHEAR: 870 FT. LBS.
VERTICAL LIFT EACH LEG MAX.: 580 FT. LBS.
OVERTURNING MOMENT: 6,380 FT. LBS.
- INSTALLED BY CUSTOMER (REQUIRED HOLE SIZE ϕ 1.28).
- MATCH DRILL AT ASSEMBLY.
- ORIENTATION OF BASE STAND ASSEMBLY WHEN USED WITH COOLING UNIT ASSEMBLY, REFERENCE GENERAL ASSEMBLY.

TOLERANCES UNLESS OTHERWISE SPECIFIED X.X = $\pm .050"$ X.XX = $\pm .020"$ X.XXX = $\pm .005"$ ANGLES = $\pm 30'$			
SCALE: 1/20 DATE: 6-13-97 TITLE:		APPROVED BY: DRAWN BY: MAB DRAWING SIZE: C	
RADOME ASSEMBLY, 144"			
3rd ANGLE PROJECTION	MODEL: 144" RADOME	SHEET: 1 OF 1	DRAWING NUMBER 111365 REVISION N1

SINGLE LEVEL MFG BILL OF MATERIAL

FIND	QTY	PART NO	REV	DESCRIPTION	REFERENCE DESIGNATOR
1	1 EA	123724-1	C	RADOME BASE FRAME ASS'Y, 75 IN, STEEL	
2	1 EA	124458-1	X1	RADOME BASE PAN FAB, WHITE, W/EXTERNA	
3	1 EA	123728-2	A	RADOME PAN ACCESS ASS'Y, WHITE	
4	1 EA	123729-1	E	A/C INSTALL ASS'Y, EXTERNAL	
50	6 EA	114586-540		SCREW, HEX HD, 1/4-20 x 1-1/4, S.S.	
52	12 EA	114580-029		WASHER, FLAT, 1/4, S.S.	
53	6 EA	114583-029		NUT, HEX, 1/4-20, S.S.	

<h1 style="margin: 0;">Sea Tel</h1> <p style="margin: 0;"><i>COBHAM</i></p>				
<p>RADOME BASE ASS'Y, 75 IN., STL, EXT. AC, WHT PAN</p>				
PROD FAMILY COMMON	EFF. DATE 12/15/2009	SHT 1 OF 1	DRAWING NUMBER 123723-5	REV B1

NOTES: (UNLESS OTHERWISE SPECIFIED)

1. APPLY ADHESIVE PER SEA TEL SPEC. 121730.

REV.	ECO#	DATE	DESCRIPTION	BY
A	N/A	1-14-05	RELEASED TO PRODUCTION	AMN
A1	NONE	04-13-05	-9 ADDED	AEF
A2	NONE	04-29-05	-9 BASE FRAME WS STL. LG. FOOT, BASE PAN WS P/N 123726-2	MSF
B	4888	05-31-05	FOR -5, -6, -8, -9 BASE PAN WAS P/N 123726-1.	V.S.
B1	N/A	01-24-07	ADD INTERNAL AC PAN FAB CUTOUTS (NOT PREVIOUSLY SHOWN).	SL.

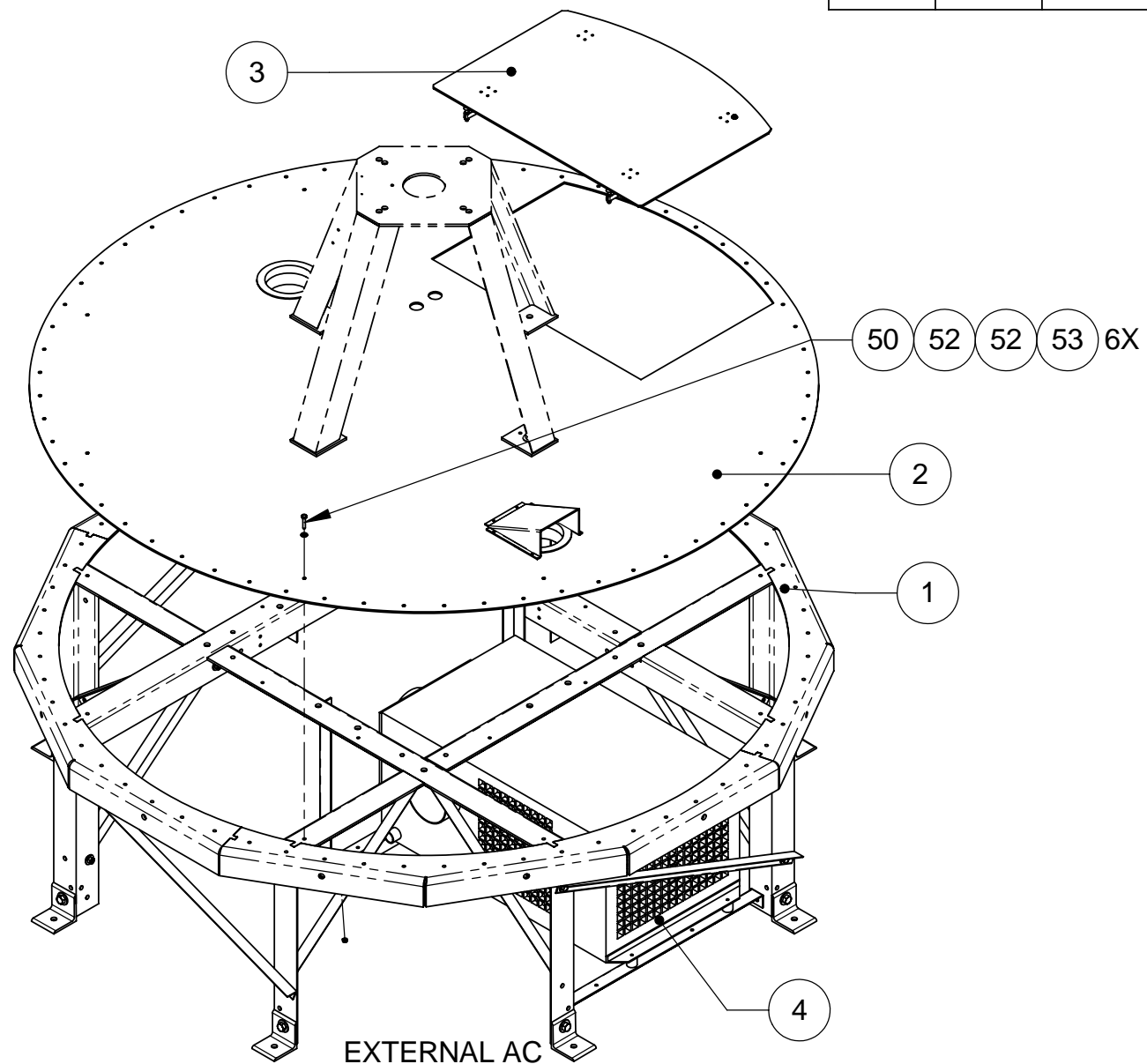

HEX SCREW, 1/4-20 X 1.25
 FLAT WASHER
 FLAT WASHER
 NUT
 6 PLCS.

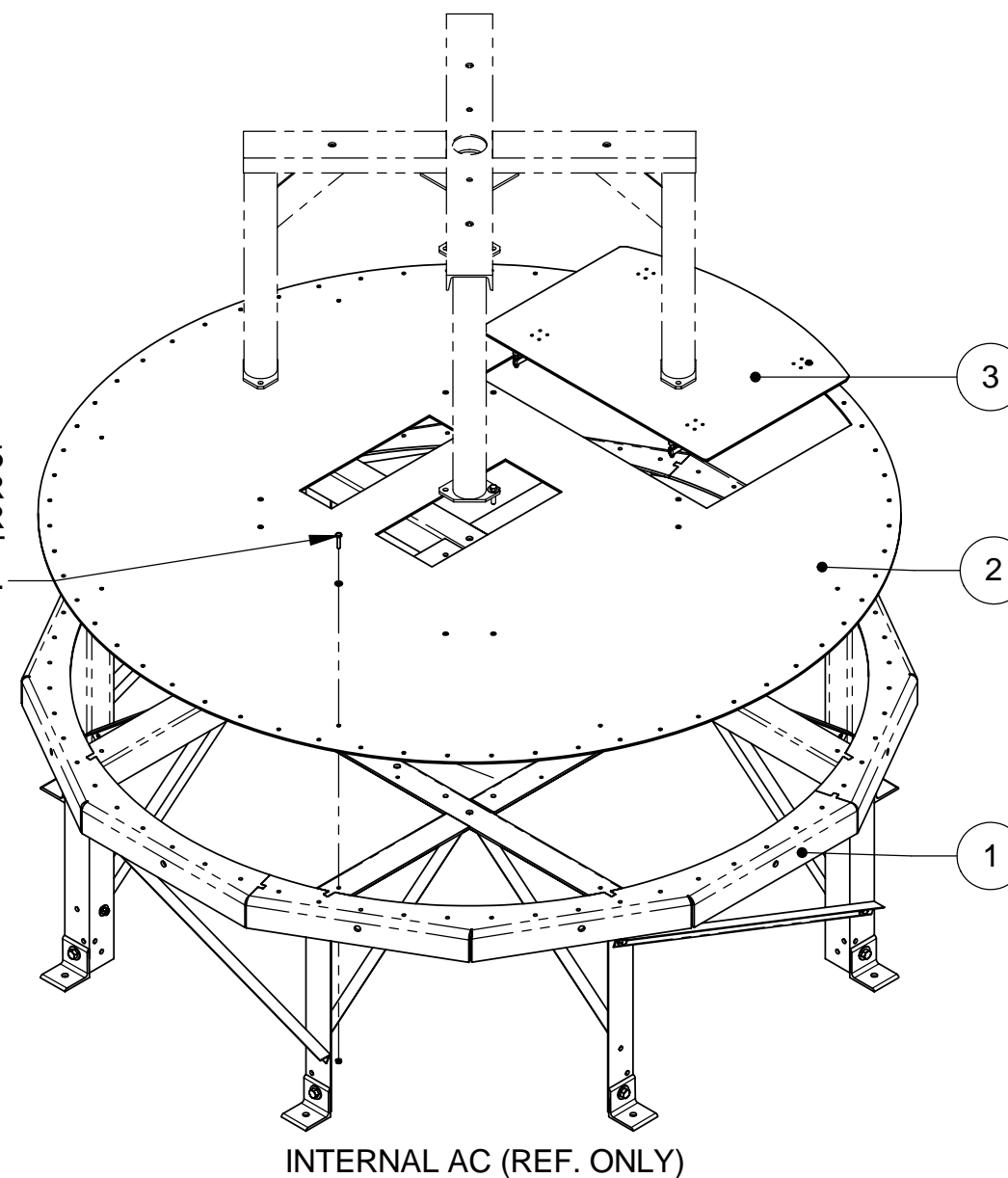

DASH #	BASE FRAME	AC OPTION	COLOR	BASE PAN	BASE PAN ACCESS ASSY
-1	STL.	NO	WHITE	123726-1	123728-2
-2	AL.	NO	WHITE	123726-1	123728-2
-3	STL.	NO	US NAVY GREY	123726-2	123728-3
-4	STL.	NO	BRT GREY	123726-3	123728-4
-5	STL.	EXTERNAL	WHITE	124458-1	123728-2
-6	AL.	EXTERNAL	WHITE	124458-1	123728-2
-7	STL. LG. FOOT	NO	WHITE	123726-1	123728-2
-8	STL. LG. FOOT	EXTERNAL	WHITE	124458-1	123728-2
-9	STL	INTERNAL	WHITE	124459-1	123728-2

TOLERANCES		SeaTel®		
UNLESS OTHERWISE SPECIFIED				
X.X	= ± .050"	SCALE: 1:16	APPROVED BY:	DRAWN BY: SCC
X.XX	= ± .020"	DATE: 12-14-04		DRAWING SIZE: B
X.XXX	= ± .005"	TITLE: RADOME BASE ASSY, 75 IN.		
ANGLES	= ± 30'	MODEL: XX97	SHEET: 1 OF 1	DRAWING NUMBER: 123723
3rd ANGLE PROJECTION				REVISION: B1

SINGLE LEVEL MFG BILL OF MATERIAL

FIND	QTY	PART NO	REV	DESCRIPTION	REFERENCE DESIGNATOR
1	1 EA	116941	0	STREET ELBOW, 1/2 INCH	
2	1 EA	116938	0	FLEX HOSE, 1/2 INCH	
3	2 EA	124903-1	B1	STRAIN RELIEF ASS'Y	
4	1 EA	121008-72	D2	CABLE ASS'Y, AC INPUT, 72 IN. (SPADE	(NOT SHOWN)
6	4 EA	120470		ISOLATORS, BUMPER	
60	4 EA	114586-535		SCREW, HEX HD, 1/4-20 x 1/2, S.S.	
61	4 EA	114586-537		SCREW, HEX HD, 1/4-20 x 3/4, S.S.	
62	8 EA	114581-029		WASHER, LOCK, 1/4, S.S	
63	4 EA	114625-107		WASHER, FENDER, 1/4, (1 IN OD), S.S.	

<h1 style="margin: 0;">Sea Tel</h1> <p style="margin: 0;"><i>COBHAM</i></p>				
<p>A/C INSTALL ASS'Y, INTERNAL</p>				
PROD FAMILY COMMON	EFF. DATE 12/15/2009	SHT 1 OF 1	DRAWING NUMBER 122508	REV E

8 7 6 5 4 3 2 1

REVISION HISTORY				
REV	ECO#	DATE	DESCRIPTION	BY
A	N/A	7-15-04	RELEASED TO PRODUCTION, CHANGED REV FROM X2 TO A	COZ
B	1884	5-15-05	ADD ITEM 3 113703-3 & HARDWARE ITEMS 50 THRU 52	L.W.
C	5050	11-11-05	ITEM 3 WAS P/N 109258-8	V.S.
D	5133	02-21-06	IN NOTE 2 P/N 121008-72 WS 121008-36 & P/N 124903-1 WS 109258-8	R.W.
E	6475	12-4-08	REMOVED ITEMS 5, 50, 51, 52 & NOTE 4; ADDED ITEMS 6, 60 THRU 63, NOTE 3 WS X.D.M. ITEM AND ATTACH POWER 5050 AND STRAIN RELIEF- ADD EXPLODE VIEW	X.D.M.

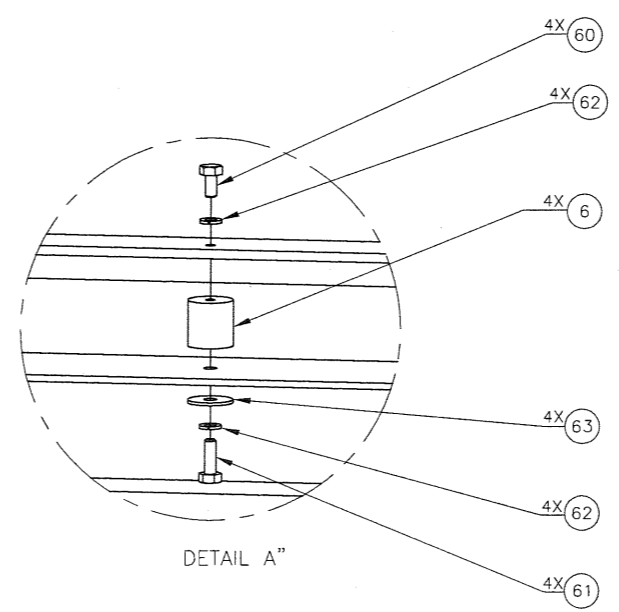
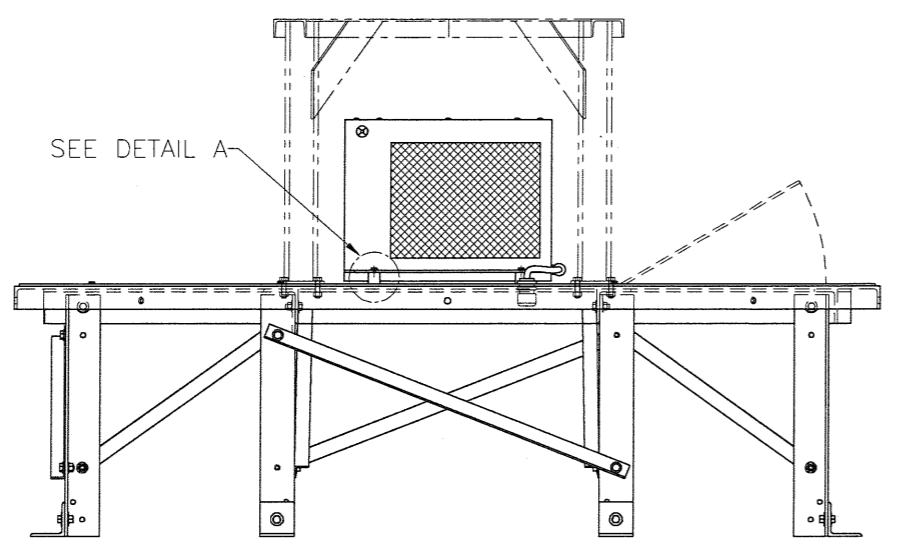
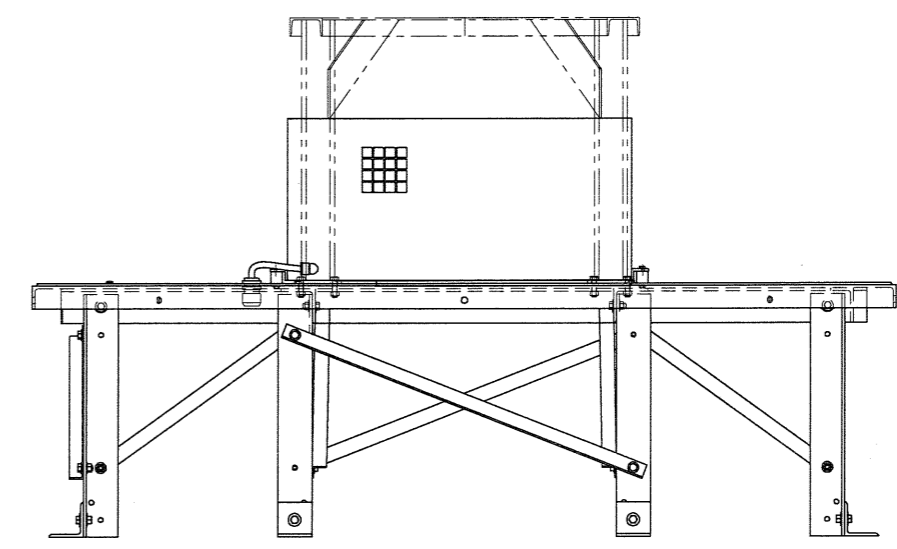
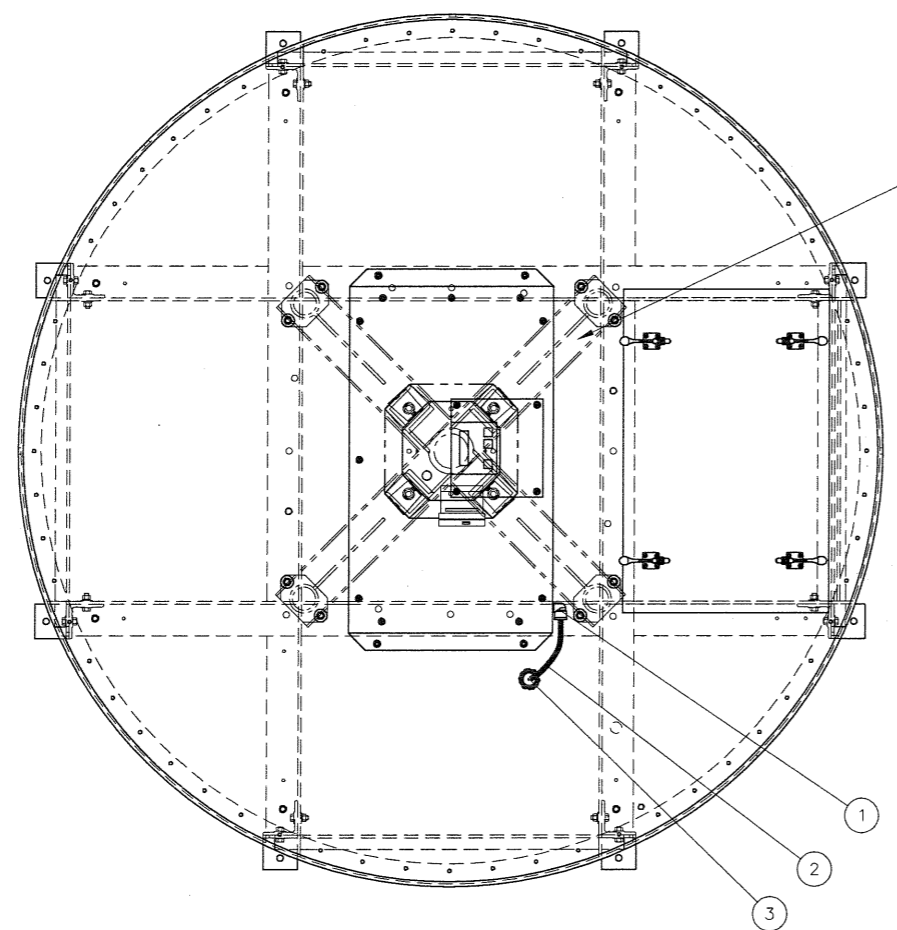

- NOTES: (UNLESS OTHERWISE SPECIFIED)
1. APPLY ADHESIVE PER SEATEL SPEC. 121730.
 2. AC POWER CORD (P/N 121008-72) AND STRAIN RELIEF (P/N 124903-1) INSTALLED BY CUSTOMER.
 3. BAG TAG ALL ITEMS ON BOM AND INCLUDE WITH A/C UNIT.

REFERENCE DOCUMENTS:
 122005, MANUAL, RADOME A/C
 122006, QUICK START CARD, RADOME A/C

UNLESS OTHERWISE SPECIFIED DIMENSIONS ARE IN INCHES: X.X = ± 0.050 X.XX = ± 0.020 X.XXX = ± 0.015 ANGLES: ± 5°	DRAWN BY: V.S.	Sea Tel Tel. 925-798-7979 Fax. 925-798-7986
	DATE: 11-19-03	
MATERIAL: N/A	APPROVED BY: <i>[Signature]</i>	TITLE: A/C INSTALL ASS'Y, INTERNAL
FINISH: N/A	SIZE: D	DRAWING NUMBER: 122508
3rd ANGLE PROJECTION	SCALE: 1/10	REV: E
	FIRST USED: XX97	SHEET NUMBER: 1 OF 1

REVISION HISTORY				
REV	ECO#	DATE	DESCRIPTION	BY
A	4609	10-05-04	RELEASED TO PRODUCTION	AMN
B	4858	5-5-05	ADD REFERENCE 121113	LR
C	N/A	3-2-06	CHANGED TO TABLE FORMAT	V.S.
C1	N/A	1-9-07	CREATED CAD OUTLINE DRAWING	RJW

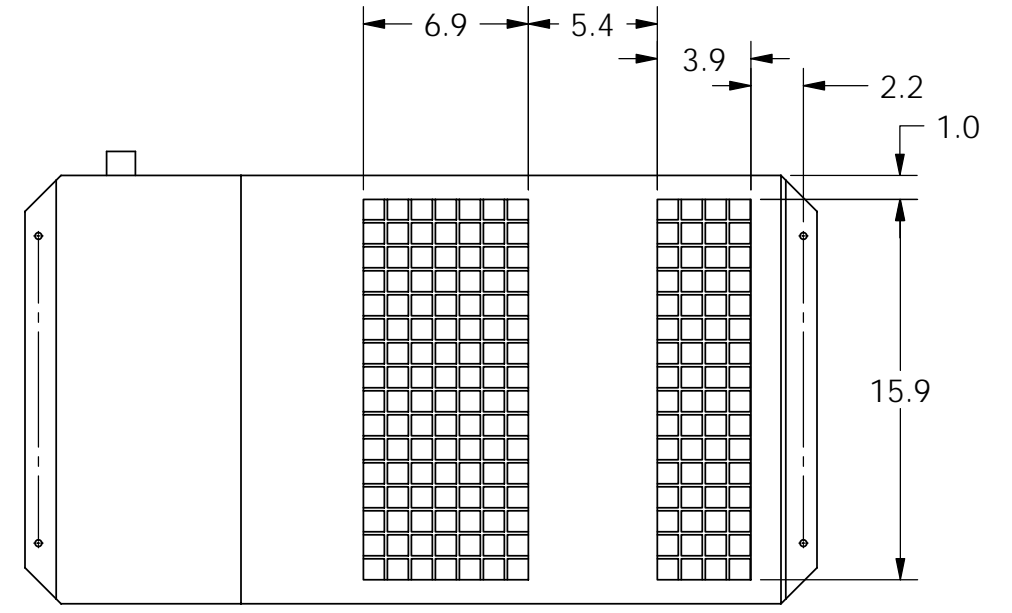
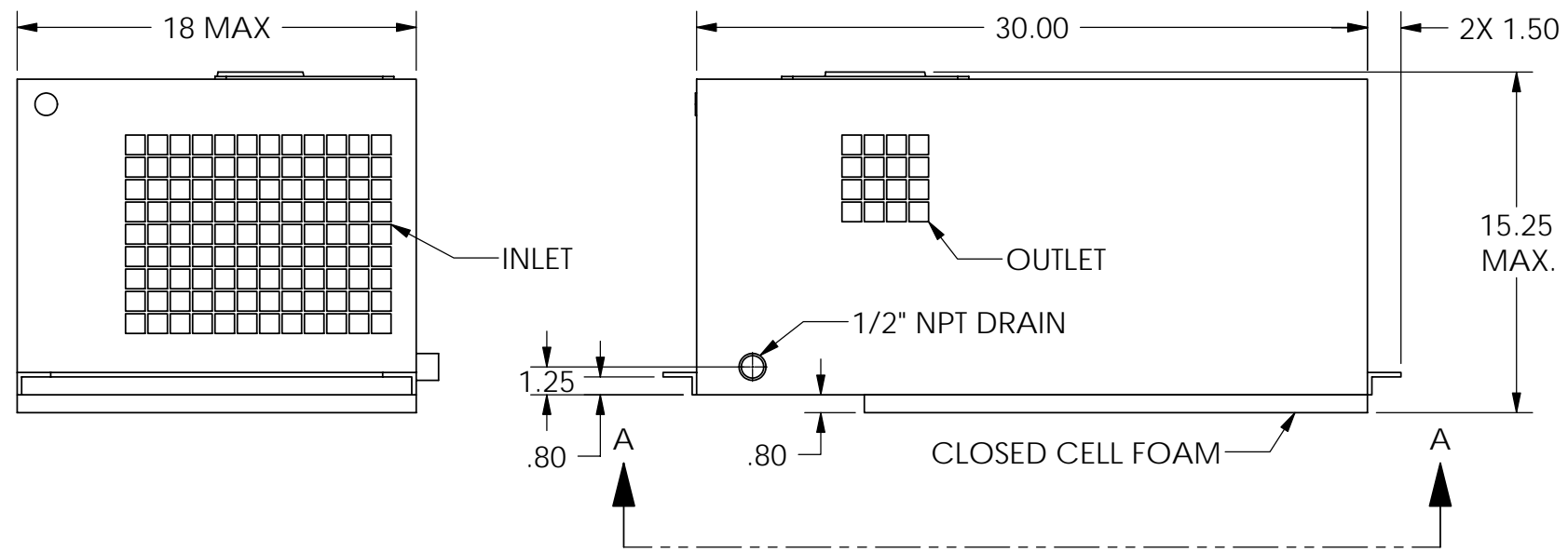
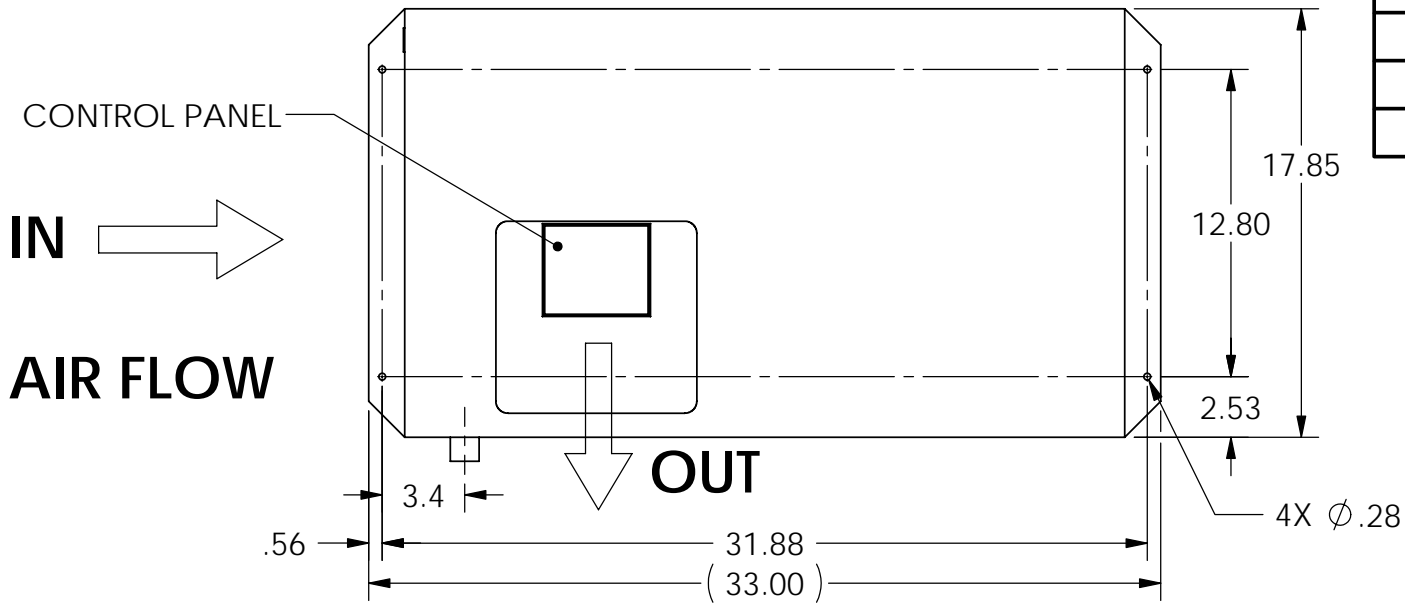

VIEW A-A
BOTTOM VIEW

Dash	Rated Cooling Capacity (BTU)	Voltage (VAC)	Rated Current	Frequency (Hz)	Refrigerant	System Controller	Manufacturer	Manufacturers Part Number	Manufacturers Description
-1	16,000	110	20A	60	R417A	Digital	Dometic	202000307	HSA16KC/2 417A RADOME 115V
-2	16,000	220	12A	50/60	R417A	Digital	Dometic	202000304	HSA16KCZ/2 417A RADOME 230/1
-3	16,000	230	12A	60	R417A	Digital	Dometic	TBD	TBD
-4	16,000	230	12A	50	R417A	Digital	Dometic	202000354	HSA16KCZ50 417A 220V/50/1

UNLESS OTHERWISE SPECIFIED DIMENSIONS ARE IN INCHES. X.X = ±.050 X.XX = ±.020 X.XXX = ±.005 ANGLES: ±.5° INTERPRET TOLERANCING PER ASME Y14.5M - 1994		DRAWN BY: RJW		 4030 NELSON AVENUE CONCORD, CA 94520 Tel. 925-798-7979 Fax. 925-798-7986	
MATERIAL: N/A		DRAWN DATE: 1/8/2007			
FINISH: N/A		APPROVED BY:		TITLE: AIR CONDITIONER, INTERNAL	
3rd ANGLE PROJECTION		APPROVED DATE:		DRAWING NUMBER 123496	
		SIZE B		SCALE: 1:8	
		FIRST USED:		REV C1	
				SHEET NUMBER 1 OF 1	

REVISION HISTORY

REV	ECO#	DATE	DESCRIPTION	BY
B	6570	3-3-09	UPDATED DWG TO SHOW XX07D OPTION WITH BRAKES	MSF

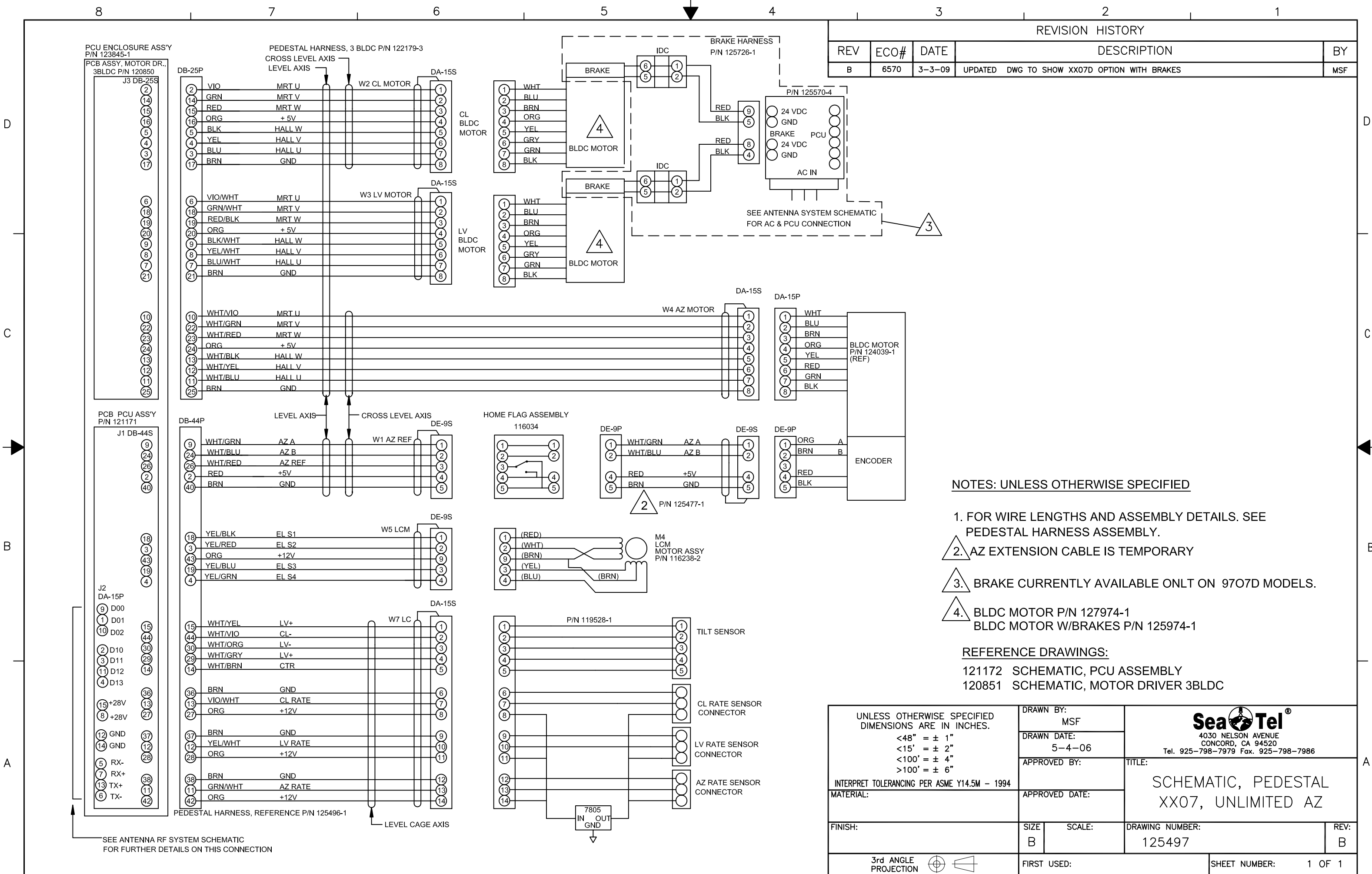

NOTES: UNLESS OTHERWISE SPECIFIED

- FOR WIRE LENGTHS AND ASSEMBLY DETAILS. SEE PEDESTAL HARNESS ASSEMBLY.
- AZ EXTENSION CABLE IS TEMPORARY
- BRAKE CURRENTLY AVAILABLE ONLY ON 9707D MODELS.
- BLDC MOTOR P/N 127974-1
BLDC MOTOR W/BRAKES P/N 125974-1

REFERENCE DRAWINGS:

- 121172 SCHEMATIC, PCU ASSEMBLY
- 120851 SCHEMATIC, MOTOR DRIVER 3BLDC

UNLESS OTHERWISE SPECIFIED DIMENSIONS ARE IN INCHES. <48" = ± 1" <15' = ± 2" <100' = ± 4" >100' = ± 6"	DRAWN BY: MSF		 4030 NELSON AVENUE CONCORD, CA 94520 Tel. 925-798-7979 Fax. 925-798-7986	
	DRAWN DATE: 5-4-06			
INTERPRET TOLERANCING PER ASME Y14.5M - 1994	APPROVED BY:		TITLE: SCHEMATIC, PEDESTAL XX07, UNLIMITED AZ	
MATERIAL:	APPROVED DATE:		DRAWING NUMBER: 125497	
FINISH:	SIZE: B	SCALE:	DRAWING NUMBER: 125497	REV: B
3rd ANGLE PROJECTION		FIRST USED:	SHEET NUMBER: 1 OF 1	

SINGLE LEVEL MFG BILL OF MATERIAL

FIND	QTY	PART NO	REV	DESCRIPTION	REFERENCE DESIGNATOR
1	1 EA	112657	D	MACHINING, TERMINAL MOUNTING STRIP	
2	1 EA	126865-2	E	PCB ASS'Y, TERMINAL MOUNTING STRIP, 5	
3	1 EA	112936-36	D1	CABLE ASS'Y, D-SDB, 25 PIN, 36 IN	
5	1 EA	116669-36	B1	CABLE ASS'Y, D-SUB, 9-PIN, 36 IN.	
7	2 EA	121228-3072		STANDOFF, HEX, F/F, 6-32 X .25 OD X .	
9	2 EA	114588-146		SCREW, PAN HD, PHIL, 6-32 x 3/8, S.S.	
11	8 EA	114588-107		SCREW, PAN HD, PHIL, 4-40 x 5/16, S.S	
19	2 EA	114588-144		SCREW, PAN HD, PHIL, 6-32 x 1/4, S.S.	
29	1 EA	119478-5	C3	CABLE ASS'Y, RJ-45 SERIAL, 60 IN.	
30	1 EA	126877	B1	HARNESS ASS'Y, COMTECH MODEM INTERFAC	

<h1 style="margin: 0;">Sea Tel</h1> <p style="margin: 0;"><i>COBHAM</i></p>				
TERMINAL MOUNTING STRIP ASS'Y, ACU				
PROD FAMILY COMMON	EFF. DATE 12/15/2009	SHT 1 OF 1	DRAWING NUMBER 121628-4	REV P

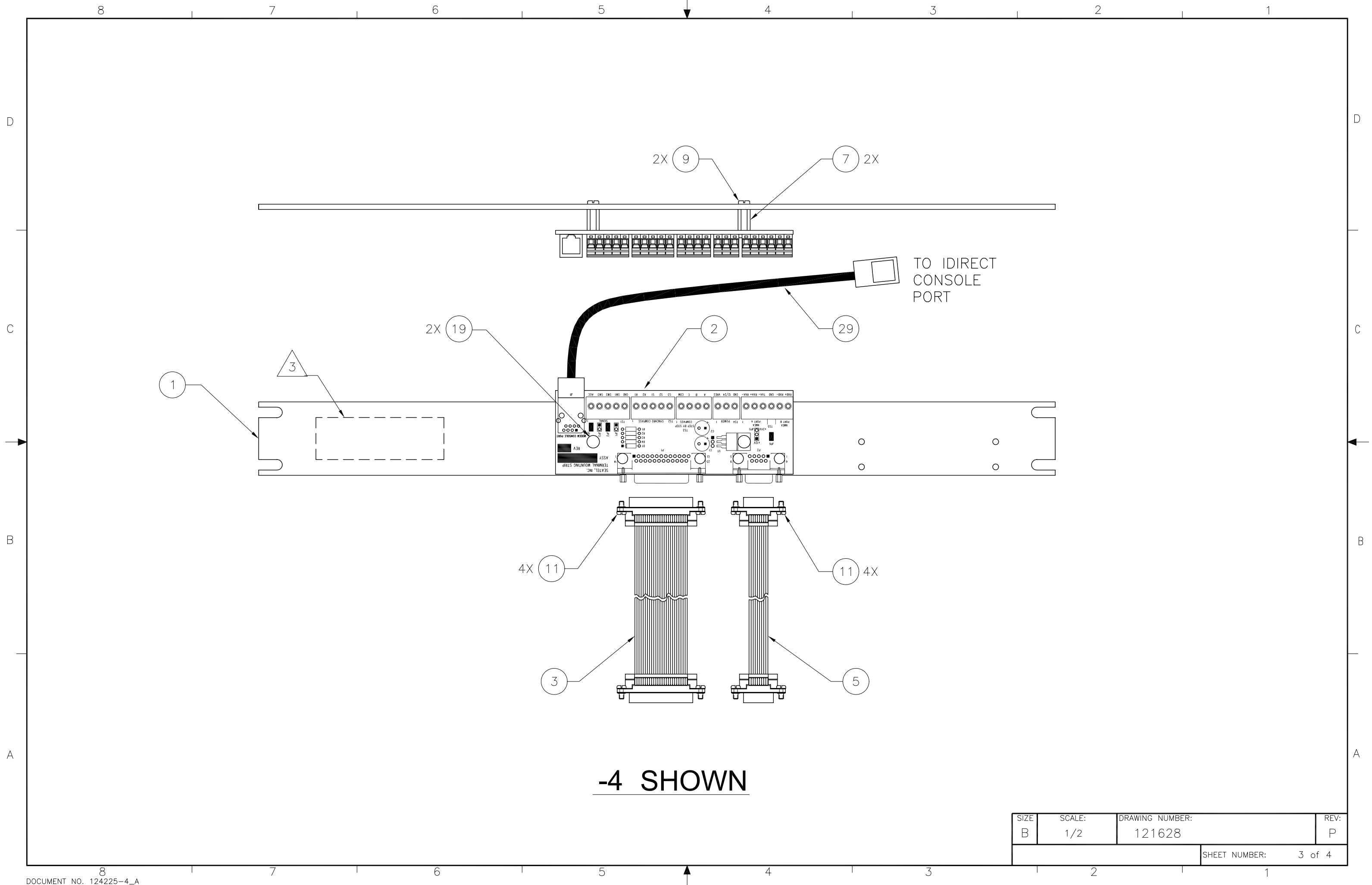

-4 SHOWN

SIZE	SCALE:	DRAWING NUMBER:	REV:
B	1/2	121628	P
SHEET NUMBER:			3 of 4

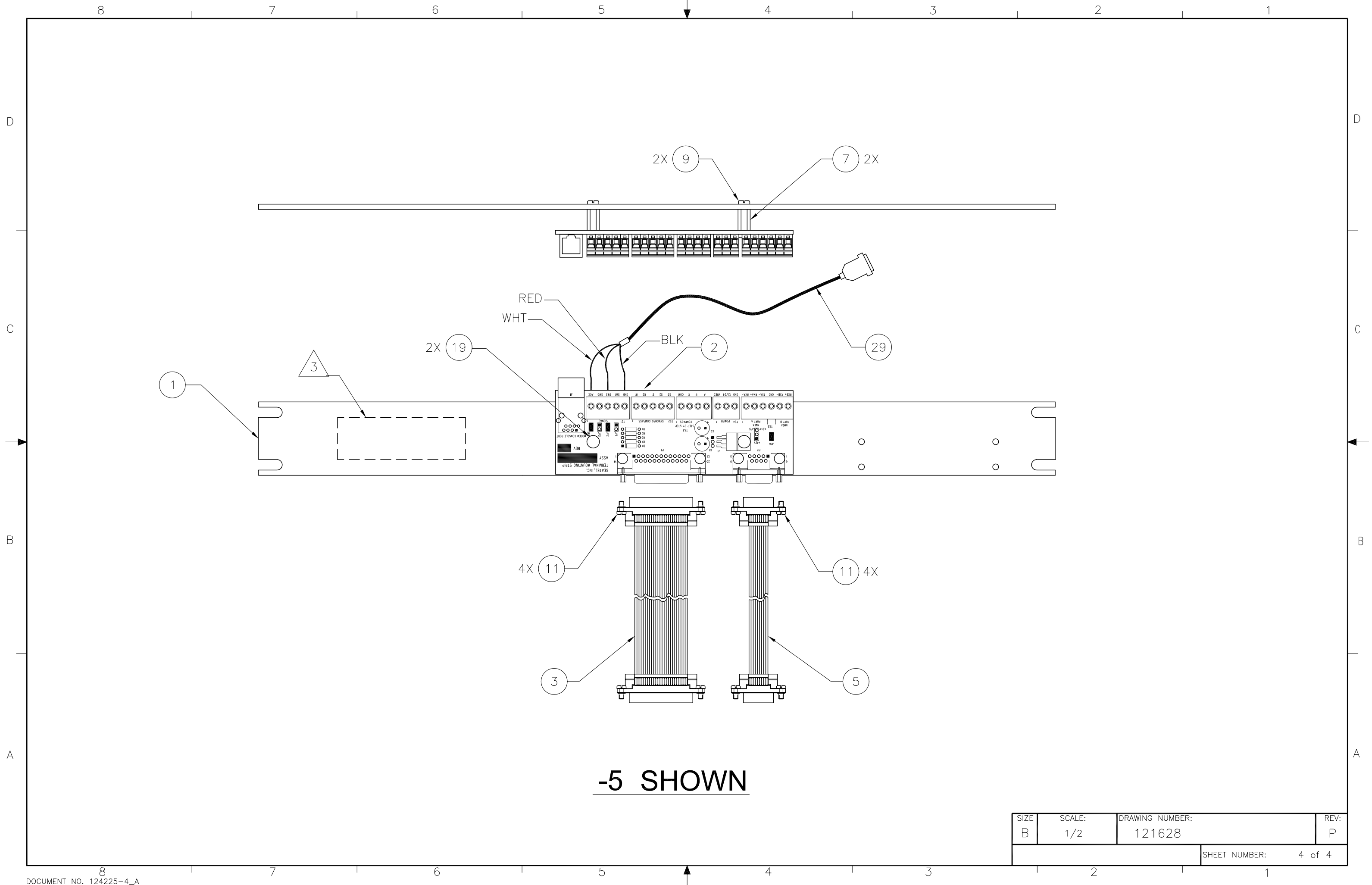

-5 SHOWN

SIZE	SCALE:	DRAWING NUMBER:	REV:
B	1/2	121628	P
SHEET NUMBER:			4 of 4

SINGLE LEVEL MFG BILL OF MATERIAL

FIND	QTY	PART NO	REV	DESCRIPTION	REFERENCE DESIGNATOR
1	1 EA	116880	G	PANEL MACHINING, RACK, BASE MUX	
2	1 EA	117168-2	P1	MODEM ASS'Y, BASE, 3 CH, 75 OHM	
3	1 EA	117611-4	H	MODEM ASS'Y, BASE, 3 CH, 50 OHM	
4	1 EA	116388	D	BRACKET, CONNECTOR	
5	1 EA	115492-1	C1	ADAPTER, N(F)-SMA(F), W/FLANGE	
6	1 EA	110567-19		ADAPTER, N(F)-N(F), STRAIGHT, FLANGE	
7	1 EA	114972-9	M	CABLE ASS'Y, SMA(M) - SMA(M), 6 IN	
8	1 EA	113303-10	T1	CABLE ASS'Y, SMA 90 - SMA (M), 8 IN	
9	1 EA	111115-1	B	CABLE ASS'Y, F(M)-F(M), 1 FT.	
10	4 EA	122569-3402	A	STANDOFF, HEX, M/F, 6-32 X .25 OD X 1	
11	8 EA	114588-107		SCREW, PAN HD, PHIL, 4-40 x 5/16, S.S	
12	8 EA	114583-005		NUT, HEX, 4-40, S.S.	
13	4 EA	114588-146		SCREW, PAN HD, PHIL, 6-32 x 3/8, S.S.	
14	6 EA	114580-007		WASHER, FLAT, #6, S.S.	
15	2 EA	114580-008		WASHER, FLAT, #6, SMALL PATTERN, S.S.	
16	1 EA	110873-4	E	RF SPLITTER, 2-WAY, 1-CH DC PASS, F	
17	4 EA	114588-144		SCREW, PAN HD, PHIL, 6-32 x 1/4, S.S.	

<h1 style="margin: 0;">Sea Tel</h1> <p style="margin: 0;"><i>COBHAM</i></p>				
<p>MUX RACK PANEL ASS'Y, RX SS, SF, SPLITTER, TX (N/N)</p>				
PROD FAMILY COMMON	EFF. DATE 12/15/2009	SHT 1 OF 2	DRAWING NUMBER 116881-18	REV D

REVISION HISTORY

REV	ECO#	DATE	DESCRIPTION	BY
C	6399	10-09-08	ITEM 17 WAS 114588-144	SL
D	6668	5-6-09	ZONE D-8, BUBBLE 17 WAS 13; BOM, ITEM 13 WS QTY 2 OF 114588-144 ITEM 17 WAS QTY 2.	K.D.H.

2X (17) (14)

(4)

8X (11) (12)

(6)

(5)

(2)

(9)

(3)

(7)

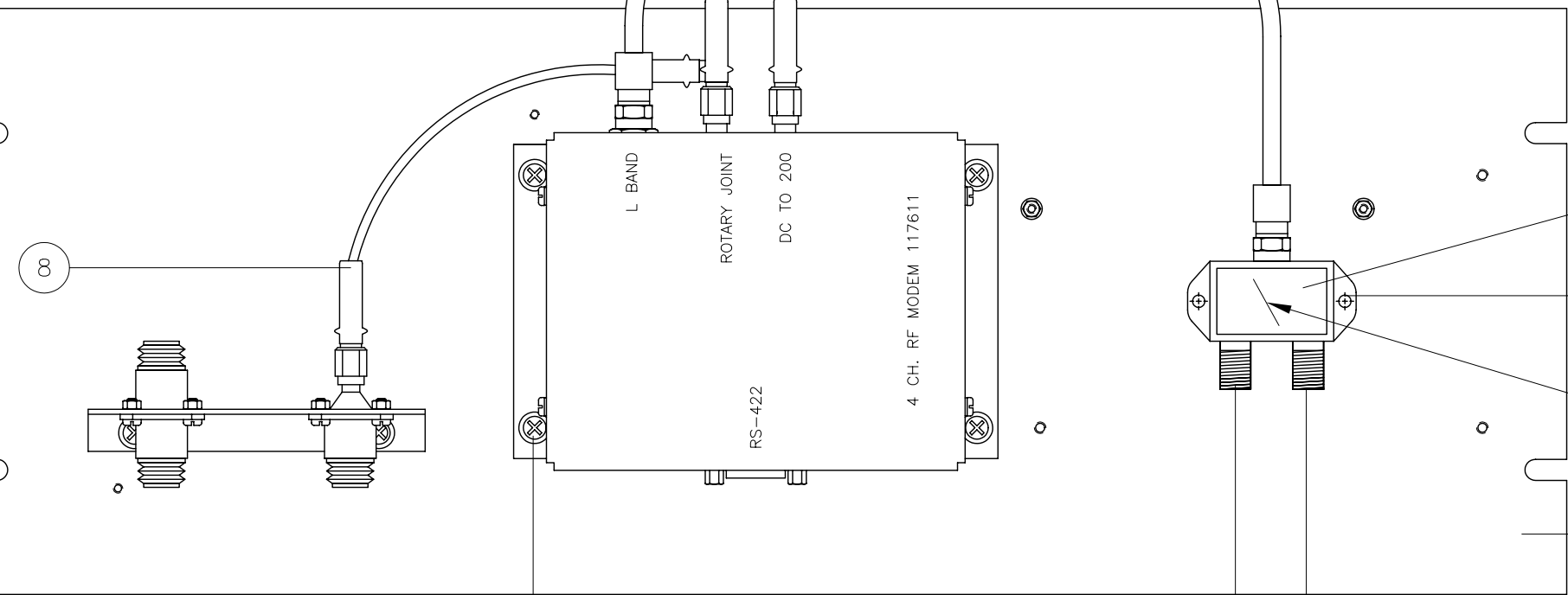

(16)

2X (17) (15)

CONNECT DAC TO DC PATH
PER SPLITTER MARKING

(1)

TO DAC

TO MODEM

4X (13) (14) (10)

NOTES:

1. APPLY ADHESIVE PER SEA TEL SPEC. 121730.

UNLESS OTHERWISE SPECIFIED DIMENSIONS ARE IN INCHES. X.X = ±.050 X.XX = ±.020 X.XXX = ±.005 ANGLES: ±.5° INTERPRET TOLERANCING PER ASME Y14.5M - 1994	DRAWN BY: V.S.	 Tel. 925-798-7979 Fax. 925-798-7986	
	DRAWN DATE: 09-22-05		
	MATERIAL: N/A	APPROVED BY:	TITLE: MUX RACK PANEL ASS'Y, RX SS,SF,SPLITER,TX (N/N)
FINISH: N/A	APPROVED DATE:	DRAWING NUMBER: 116881-18	REV: D
3rd ANGLE PROJECTION	SIZE: B	SCALE: 1:2	SHEET NUMBER: 1 OF 1
FIRST USED: 4006-23		SHEET NUMBER: 1 OF 1	